

LUTHMAN SURVEY  
 PART E 1/2, NW 1/4, SEC 1, T7S, R2E, BUTLER TWP.  
 MERCER CO., OHIO

11-C

1101100003

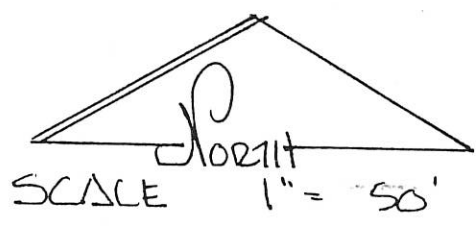
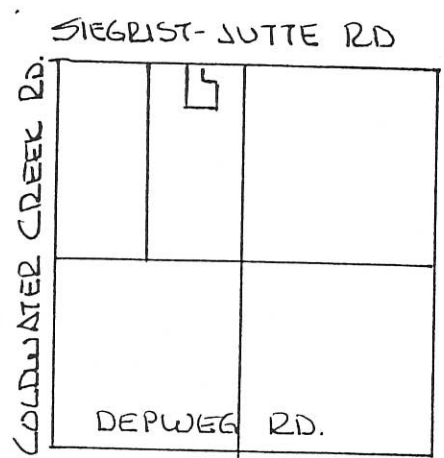

- LEGEND
- △ STONE REF
  - NAIL SET
  - IRON PIN SET
  - EXIST 8"X8" COR. POST.

DEED REF. VOL 192 PG 91

SEC 1 T7S R2E BUTLER TWP.



BEARINGS TURNED FROM  
 NORTH LINE NW 1/4 SEC. 1  
 & SIEGRIST-JUTTE RD ASSUMED  
 EAST-WEST.

PLAT BY SURVEY MAY 1996

*Roy F. Thompson, Jr.*  
 ROY F. THOMPSON, JR.  
 REG. SUR. # 5379.

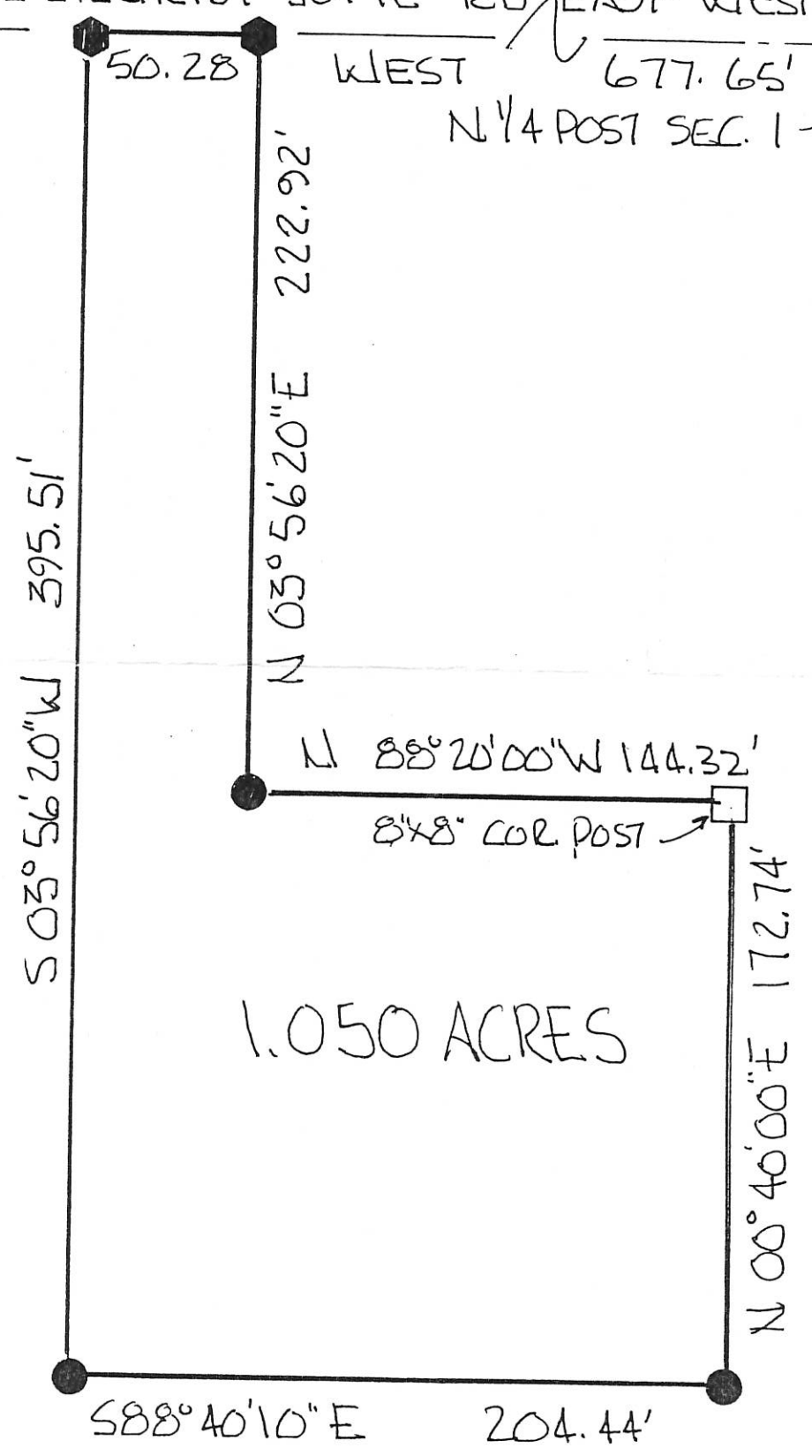

PERMANENT PARCEL No. _____		
Part of: <u>NW 1/4</u> Sec. <u>1</u> <u>T7S</u> <u>R2E</u> <u>BUTLER</u> Township		
Grantor: <u>LUTHMAN</u>	Area Retained: <u>1.050</u>	Acres
Grantee: <u>LUTHMAN</u>	Area Transferred: <u>78.63</u>	Acres
Deed References: <u>Vol 192 Pg 91</u>		
APPROVALS:		
AGENCY: <u>Board of Health</u>	<u>Co. Sanitary Engineer</u>	<u>County Engineer</u>
DATE:		

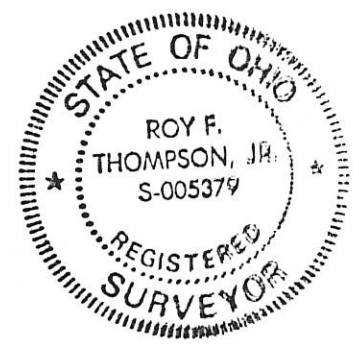

1101200001

11-C

SURVEYED BY Gordon L. Geeslin  
GORDON L. GEESLIN  
REGISTERED SURVEYOR  
No 5372  
540 E. MARKET ST. N. CELINA  
OHIO

"A" N. LINE ~ N.E. 1/4 ~ SECTION ONE & "B"  
E. OF SIEGRIST ~ JUTTE ROAD.  
EAST ~ 647.56 "C" EAST ~ 272.21 "C"

LEGEND  
"A" = STONE F.D. @ N. 1/4 POST ~ SECT 1  
"B" = CAP & NAIL SET ON SPLIT OF  
CURBS @ S.R. 127. DUG FOR  
STONE @ N.E. CORN ~ SECT. ONE  
BUT IT HAS BEEN REMOVED  
BY STATE CONSTRUCTION.  
"C" = SQUARE HEAD CROSSING BOLT  
SET.  
"D" = 5/8" IRON BAR SET.

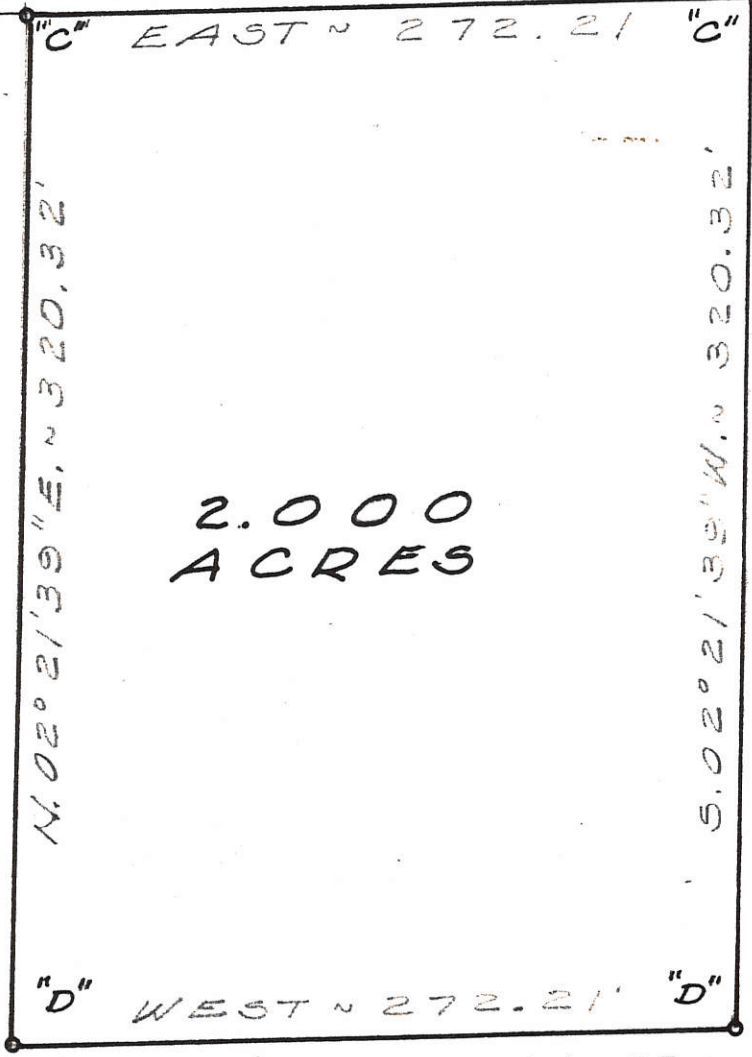

THIS BEARING ASSUMED,  
ALL OTHERS CALCULATED.



WILKER SURVEY ~ PART OF THE  
W. 1/2 OF THE N.E. 1/4 OF SECTION 1,  
TOWN 7 SOUTH, RANGE 2 EAST (BUTLER  
TWP.), MERCER COUNTY, OHIO.

JUNE, 1979

SCALE 1" = 60'

1101200007 - 008 11-C



**Legend:**

- ▲ Cornerstone @ N 1/4 Post Section 1
- ▲ Survey Marker Nail @ NE Corner Section 1
- 5/8" X 30" Iron Pin with cap set
- MAG Nail set

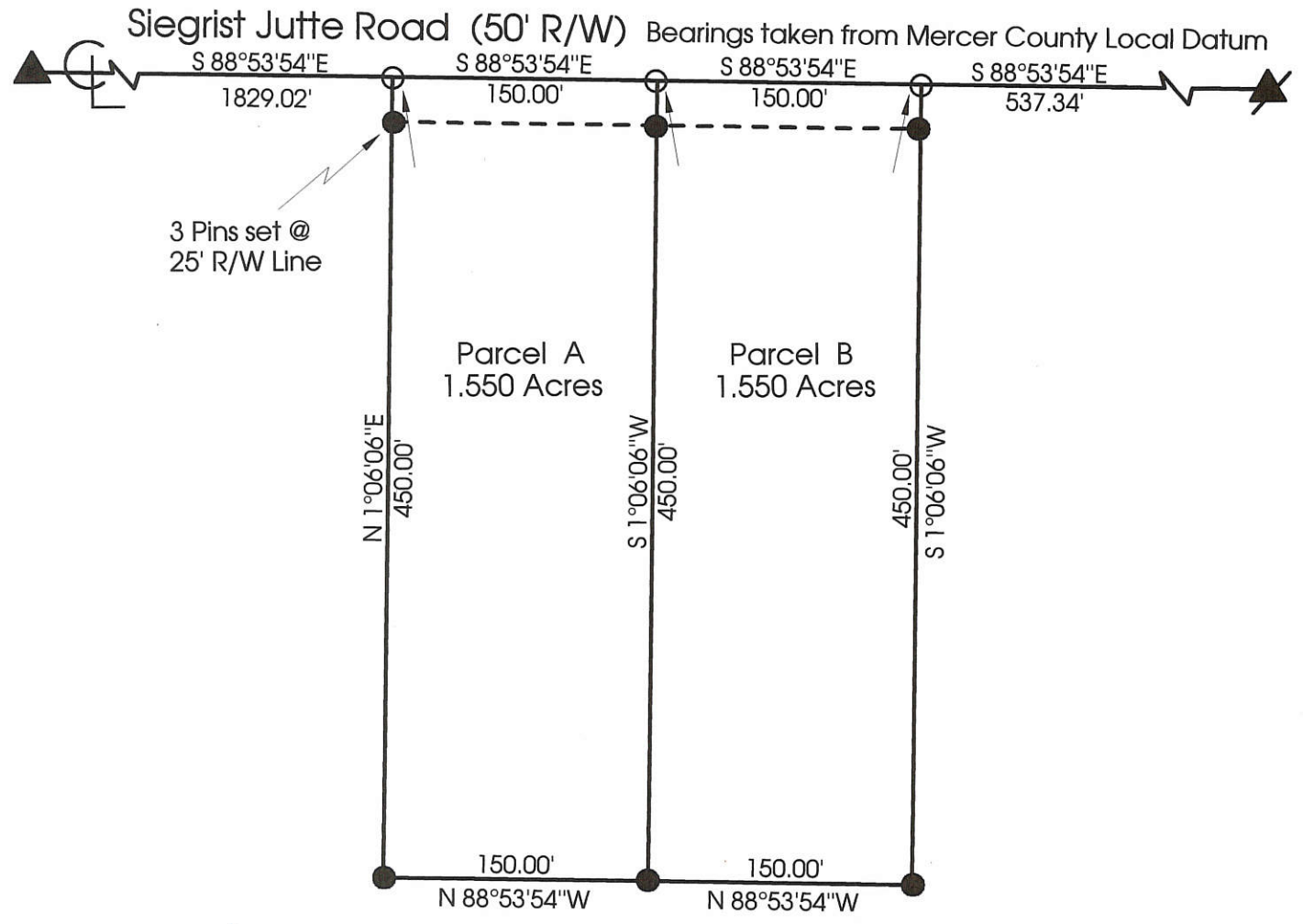
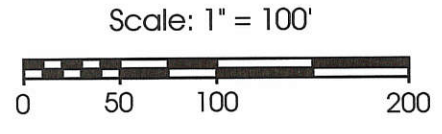

**Marbaugh Land Surveying**

1210 Yorkshire Court  
Celina, Ohio 45822  
(419) 586-4293

*Kent Marbaugh*  
Kent B. Marbaugh P.S. 7421



**Siegrist Survey**

State of: Ohio County: Mercer

Township: Butler Sec: 1 Town: 7S Range: 2E

City/Village: \_\_\_\_\_ Subdivision: \_\_\_\_\_ Lot: \_\_\_\_\_

Deed Ref: Vol. 334 Pg. 754 Date Surveyed: 8-30-99

Approvals: Michelle Kimmel \_\_\_\_\_  
Agency: Board of Health County Sanitary Engineer John Ellinger  
Date: 9/7/99 9-7-99



# SURVEY OF A 1.190 ACRE PARCEL FOR RICHARD C. & KEITH SELHORST LOCATED IN THE S.W. 1/4 OF SEC. 1, T-7-S, R-2-E, BUTLER TWP., MERCER CO., OHIO

W. 1/4 POST  
SECTION 1

NOTE:  
STONE AT WEST 1/4 POST OF SECTION WAS  
PREVIOUSLY DUG FOR BY COUNTY & NOT FOUND.  
USED OCCUPANCY TO ESTABLISH LINE & SPLIT  
THE MILE EVENLY FOR DISTANCE. SET PK NAIL IN  
AGREEMENT WITH THE COUNTY ENGINEERS OFFICE.

EX. 30'  
R/W

953.17'

S 88°13'05" E 188.00'

N 01°46'55" E 2657.02'

COLDWATER CREEK RD. (60' R/W)  
275.70'

OWNER: RICHARD C. & KEITH SELHORST  
O.R. VOL. 175, P. 810  
(120 AC. DEED)

AREA SURVEYED  
1.190 ACRES TOTAL  
-0.190 ACRES R/W  
1.000 ACRES NET

S 01°46'55" W 275.70'

4" FIELD TILE

1428.15'

N 88°13'05" W 188.00'

NOTE: IRON PINS WERE NOT SET AT THE  
REQUEST OF THE PROPERTY OWNER

S.W. CORNER  
SECTION 1

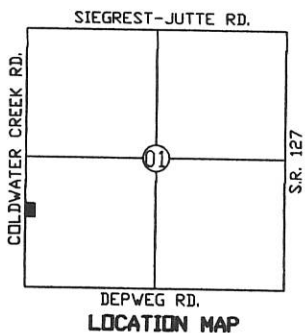

APPROVAL  
*Jan A. Jacob*  
BUTLER TOWNSHIP ZONING INSPECTOR



### LEGEND

- ∅ P.K. Nail Found
- ⊗ P.K. Nail Set

Surveyed By: *Eric C. Thomas*  
Eric C. Thomas Reg. Surveyor No. 7236  
Date: 05-09-05

References:  
G.P.S. OF SECTION STONES

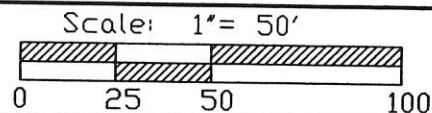

Part of S.W. 1/4 Sec. 1 T-7-S R-2-E BUTLER Twp., Mercer Co., OH  
Grantor: \_\_\_\_\_ Deeds: \_\_\_\_\_ Area Retained: \_\_\_\_\_ Ac.  
Grantee: \_\_\_\_\_ Area: \_\_\_\_\_ Ac.

Approvals:  
Agency: Bd. of Health \_\_\_\_\_ Co. San. Eng \_\_\_\_\_ Co. Engineer \_\_\_\_\_ Permanent Parcel No. \_\_\_\_\_  
Date: \_\_\_\_\_



1101300001

GAS WELL LOCATION  
 RICHARD SELHORST FARM  
 SW 1/4 SW 1/4 SEC. 1, T7S, R2E  
 BUTLER TWP., MERCER CO., OHIO

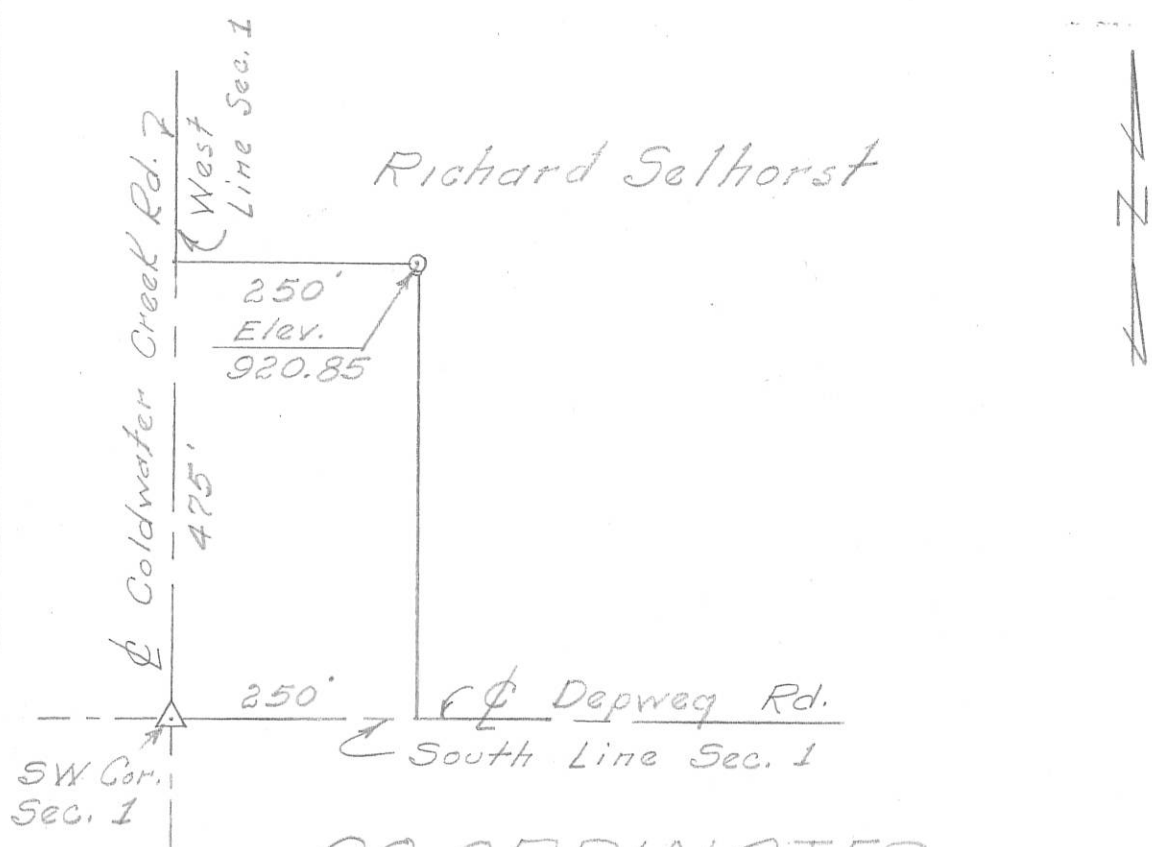

CO-ORDINATES:  
 NORTH ↖ 293,000  
 EAST ↗ 1,418,400

TYPE OF WELL

SCALE IN FEET

200 0 200 400

1" = 200'

.. Oil or Gas  
 .. Salt or Brine  
 .. Core Test  
 ..

New Location..   
 Drill Deeper ..   
 Abandonment ..

Wells located in township and range areas should be surveyed from section or half-section lines, and in Military Land Areas from lot lines or other original subdivision boundaries. All such corners or lines should be indicated.

Company West Ohio Gas Co.  
 Address 319 W. Market Lima, Ohio  
 Farm Richard Selhorst Acres 80  
 Well No. 1 Elevation (Spirit Level) 920.85  
 Section 1 Lot      Twp. Butler  
 County Mercer Date 10/6/71

Plat Showing Proposed Location  
 of  
 WELL  
 State of Ohio  
 Department of Industrial Relations  
 Division of Mines  
 Columbus

**CERTIFICATE OF SURVEYOR**  
 I, the undersigned, hereby certify that this map is true and correct as required by the General Code of Ohio.  
P. R. [Signature] Registered Surveyor No. 3909

**ACKNOWLEDGED**  
 Before me a Notary Public in and for  
Mercer County, Ohio, this  
6th day of October 1971. My  
 commission expires 11-14-72  
Ray Eblen  
 Notary Public

FRANKLIN BLUE PRINT & SUPPLY CO.



RAY EBLEN  
 Notary Public in and for  
 Mercer County, Ohio  
 My Commission Expires Nov. 14, 1972



1101300005

### LEGEND

- "A" = COR. STONE @ S.W. COR ~ SEC. 1.
- "B" = " " @ S.E. COR. ~ S.W. 1/4 ~ SEC. 1.
- "C" = "P.K." NAIL SET.
- "D" = MINE SPIKE SET.
- "E" = 5/8" x 30" IRON BAR SET.

### LOCATION SKETCH

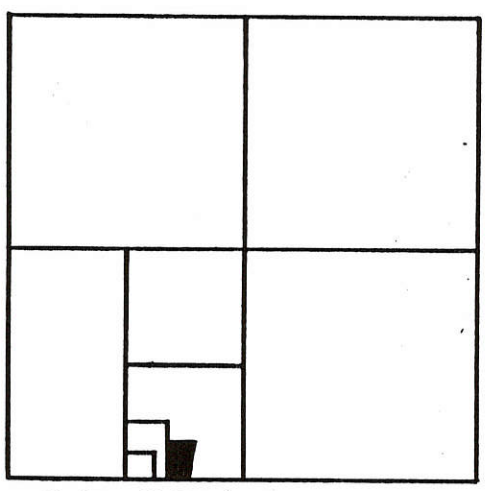

SECTION 1

# N



N.W. COR ~ E. 1/2 ~ S.W. 1/4 ~ SEC. 1

W. LINE ~ E. 1/2 ~ S.W. 1/4 ~ SEC. 1  
17.00° 00' 05" E. ~ 2654.84

N. 89° 21' 45" E.  
290.00

S. 89° 21' 45" W.  
201.80 "E"

1.869  
ACRES

N. 89° 21' 45" E.  
275.00

S. 00° 00' 05" W. ~ 480.00  
440.09

N. 04° 22' 03" E.  
441.74

160.00

160.00

15.00

30' R-O-W LINE

"D" 168.17

875.46 "B"

1333.63 "A"

275.00

N. 89° 21' 45" E. ~ 2667.26 "C"

S. LINE ~ S.W. 1/4 ~ SEC. 1 & DEP WEG RD.  
(BEARING ON THIS LINE WAS ASSUMED)

SURVEYED BY Gordon L. Geeslin

GORDON L. GEESLIN  
REGISTERED SURVEYOR  
N# 5372.

## NEDERMAN SURVEY

PART OF THE S.E. 1/4 OF THE S.W. 1/4 OF SECTION 1, TOWN 7 SOUTH, RANGE 2 EAST, (BUTLER TWP.) MERCER CO., OHIO.

JULY 5, 1990

SCALE 1" = 100'



**GORDON L. GEESLIN**  
 LAND SURVEYOR  
 810 EAST MARKET STREET  
 CELINA, OHIO  
 PHONE (419) 586-6155



PERMANENT PARCEL No. \_\_\_\_\_

Part of: SW 1/4 Sec. 1 T 7S R 2E Butler Township

Grantor: \_\_\_\_\_ Area Retained: \_\_\_\_\_ Acres

Grantee: \_\_\_\_\_ Area Transferred: 1.869 Acres

Deed References: \_\_\_\_\_

APPROVALS:  
 AGENCY: \_\_\_\_\_ DATE: \_\_\_\_\_  
 Board of Health \_\_\_\_\_ County Sanitary Engineer \_\_\_\_\_  
 NA \_\_\_\_\_  
 \_\_\_\_\_ County Engineer

FILED IN SURVEY BOOK

**LOCATION SKETCH**

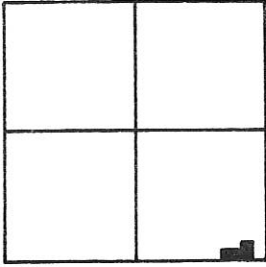

**SECTION 1**

**SURVEY REF.**

GERLACH SURVEY,  
BY ME, DATED  
1-26-89; BEARING  
BASIS FROM SAID  
SURVEY.

**LEGEND**

- ⊙ = RIGHT-OF-WAY MONUMENT FD.
- = MINE SPIKE SET.
- = 5/8" x 30" IRON BAR SET.

1101400004

SURVEYED BY Gordon L. Geeslin  
GORDON L. GEESLIN  
REG. SURVEYOR 5372

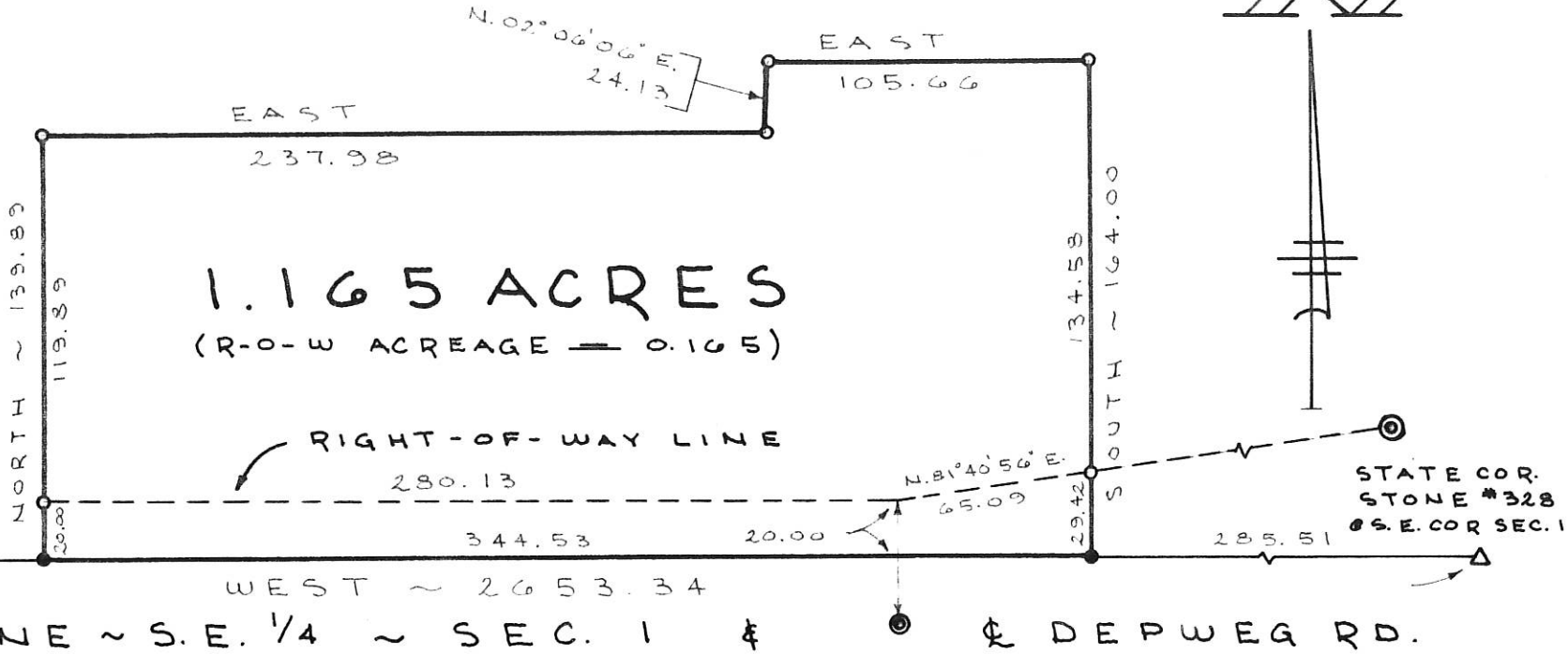

**1.165 ACRES**  
(R-O-W ACREAGE = 0.165)

COR. STONE  
E.S. 1/4 POST  
SEC. 1

STATE COR.  
STONE #328  
S.E. COR SEC. 1

S. LINE ~ S.E. 1/4 ~ SEC. 1 & DEP WEG RD.

**ALBERS SURVEY**

PART OF THE S.E. 1/4 OF SECTION 1, TOWN  
7 SOUTH, RANGE 2 EAST, (BUTLER TWP.),  
MERCER COUNTY, OHIO.

JULY 25, 1991

SCALE 1" = 60'



PERMANENT  
PARCEL No.

Part of: Sec. \_\_\_ T. \_\_\_ R. \_\_\_ Township

Grantor: Area Retained: Acres

Grantee: Area Transferred: Acres

Deed References:

APPROVALS  
AGENCY  
DATE

Board of Health

County Sanitary Engineer

County Engineer

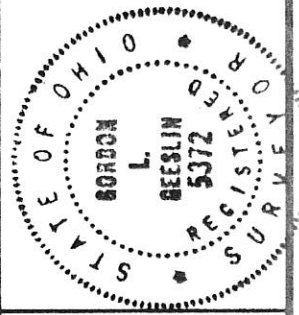

**GORDON L. GEESLIN**

LAND SURVEYOR

810 EAST MARKET STREET

CELINA, OHIO

PHONE (419) 586-6155

11-C

MERCER CO. ENGR.



C. J. SIEGRIST SURVEY  
PART SE 1/4 NE 1/4 SEC. 1  
T7S, R2E, BUTLER TOWNSHIP  
MERCER CO., OHIO

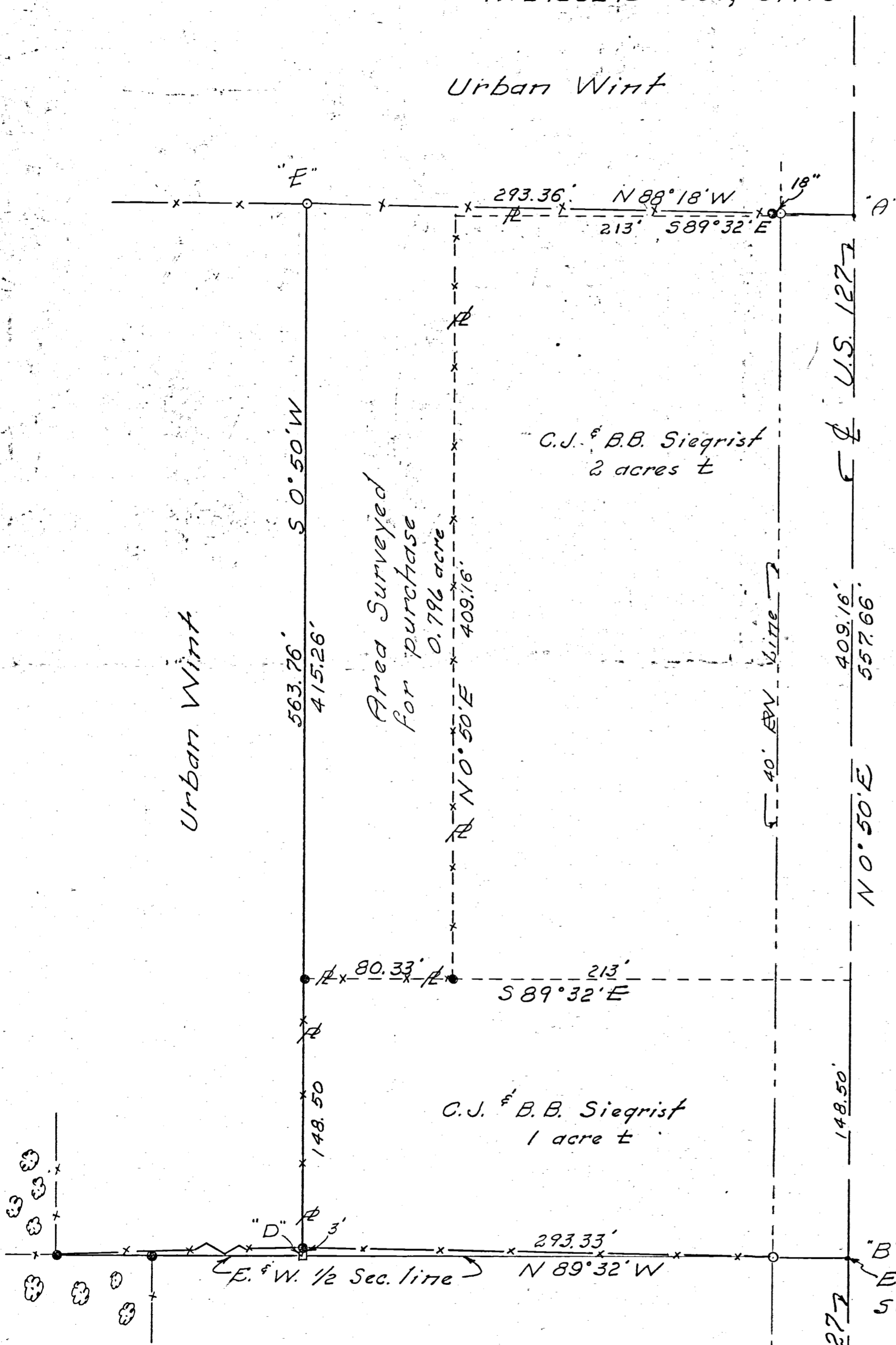

Scale: 1" = 50'  
Legend:  
○ = Iron Pipe  
● = Wood Corner Post  
□ = Wood Stake

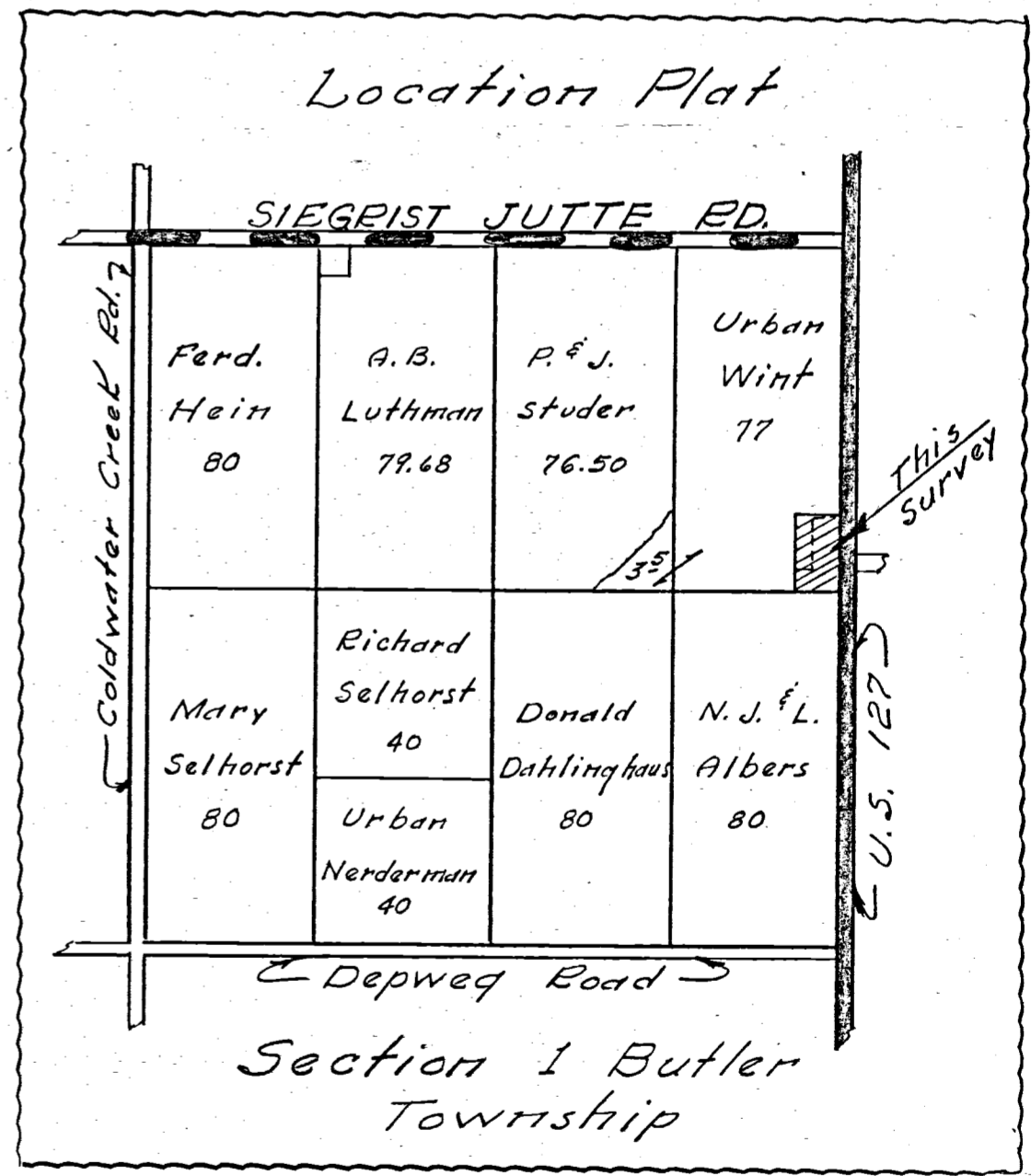

To all parties interested in title to premises surveyed, I hereby certify this survey showing corner markers is correct to the best of my knowledge and belief.

3/25/66

B. R. Gebhart  
Registered Surveyor #3909





C. J. SIEGRIST SURVEY  
PART SE 1/4 NE 1/4 SEC. 1  
T 75, R 2 E, BUTLER TOWNSHIP  
MERCER CO., OHIO

Urban Wint

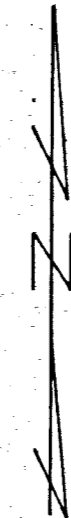

Scale: 1" = 50'  
Legend:

- = Iron Pipe
- = Wood Corner Post
- = Wood Stake
- ⊗ = Patented iron survey stake

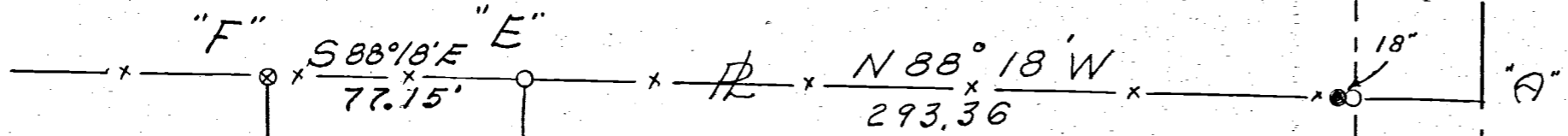

Urban Wint

Area Surveyed  
1 Acre

C. J. & B. B. Siegrist  
3.79 acres ±

40' BY LINE

U.S. 1277  
N 0° 50' E 557.66'

N 0° 50' E 565.36'

563.76'  
S 0° 50' W

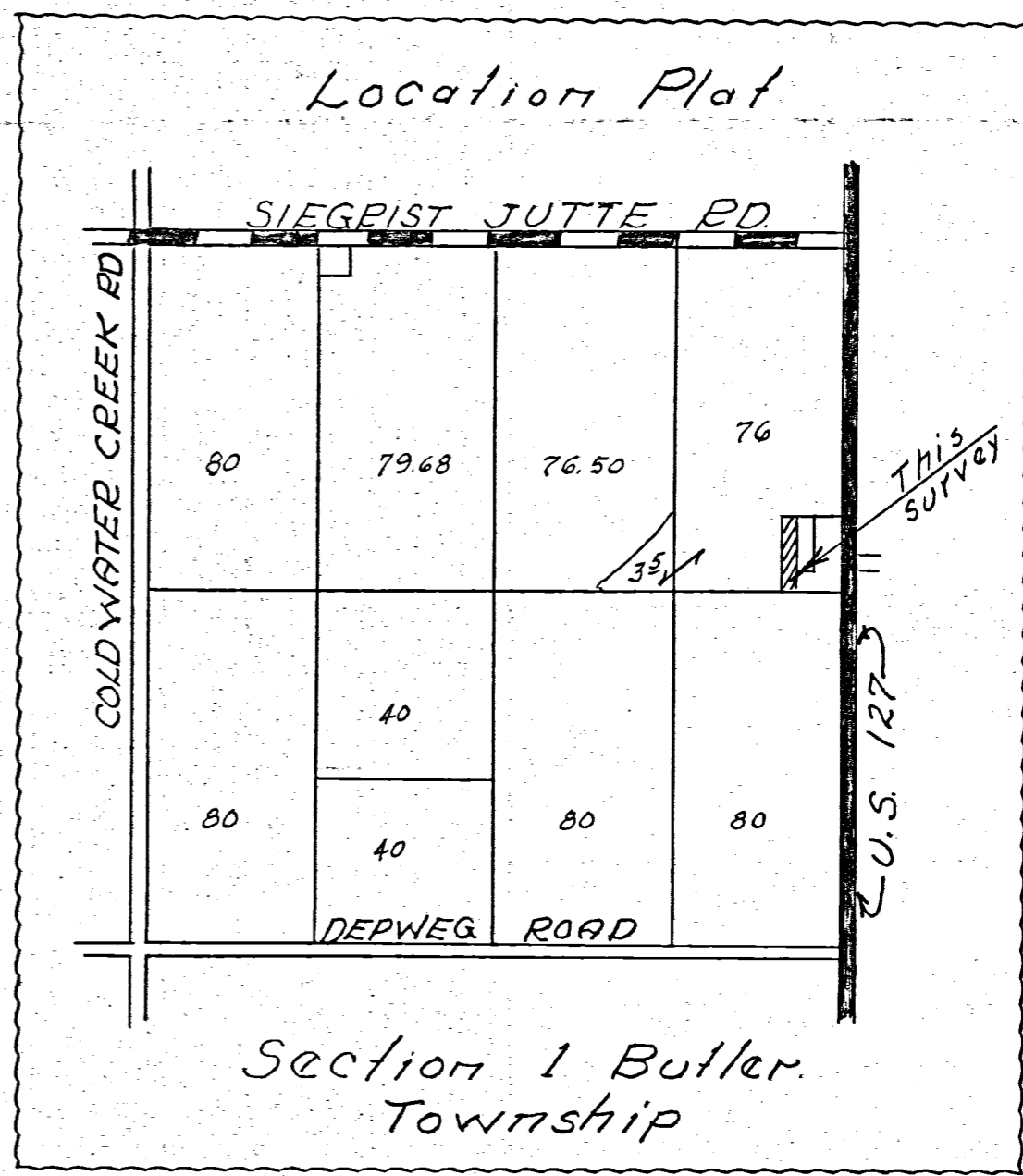

Section 1 Butler Township

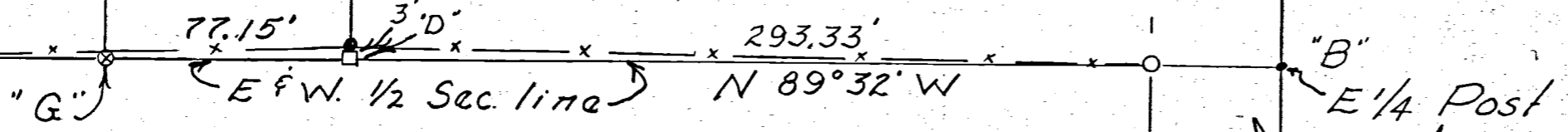

N. J. & L. Albers

To all parties interested in title to premises surveyed, I hereby certify this survey showing corner markers is correct to the best of my knowledge and belief.

1/22/69

*B. R. DePella*  
Registered Surveyor # 3909

# LUTHMAN RETRACEMENT SURVEY

N.W. 1/4 SEC. 1, T 7S, R 2E  
BUTLER TWP., MERCER CO., OH.

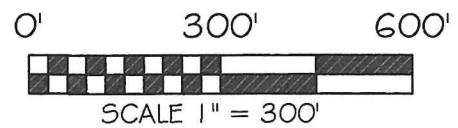
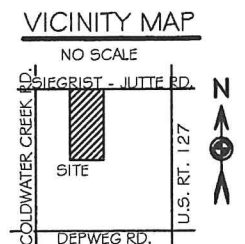

BASIS OF BEARING: BEARINGS ARE BASED UPON THE MERCER COUNTY ENGINEER'S LOCAL COORDINATE SYSTEM WITH THE NORTH LINE OF THE NORTHWEST QUARTER OF SECTION 1 BEING SOUTH 89°06'14" EAST.

### LEGEND

- 5/8x30" IRON PIN (SET) W PINK PLASTIC CAP STAMPED "LOCK TWO 7988"
- ⊙ MAG NAIL (SET)
- ◇ PATENTED SURVEY STAKE (FOUND)
- ⊙ POST

### SURVEY REFERENCES

- DUES SURVEY BY GORDON GEESLIN, FEB., 1988
- NEEDERMAN SURVEY BY GORDON GEESLIN, JULY, 1990
- LUTHMAN SURVEY BY ROY THOMPSON, MAY, 1996
- SIEGRIST SURVEY BY KENT MARBAUGH, AUG., 1999
- SELHORST SURVEY BY ERIC THOMAS, MAY, 2005

MARVIN H. EVERS (TRUSTEE)  
INST. #201000003315 &  
RUTH M. EVERS (TRUSTEE)  
INST. #201000003316  
80 ACRES

JOANNE C. LUTHMAN (TRUSTEE)  
INST. # 201200001672  
79.63 ACRES

80.590 AC. TOTAL  
0.740 AC. RW  
79.850 AC. NET

KEITH SELHORST  
INST. #200800005375  
118.81 ACRES

DAVID J. & GINA SCHMITMEYER  
O.R. 1 PAGE 549  
74.5 ACRES

N.W. COR.  
N.W. QTR.  
SEC. 1

N.E. COR.  
N.W. QTR.  
SEC. 1



*Christopher S. Harmon*  
CHRISTOPHER S. HARMON P.S. #7988

11/14/19  
DATE

SURVEY NOTE:  
I HEREBY STATE THAT THIS IS A TRUE AND ACCURATE SURVEY AS PERFORMED BY MYSELF. ALL ADJOINING OWNERS, MONUMENTS AND THERE CONDITION ARE CURRENT AS OF THE TIME THE FIELD WORK WAS PERFORMED IN NOVEMBER, 2019 AND DONE WITHOUT THE BENEFIT OF A TITLE SEARCH.

**LOCK-TWO SURVEYING**  
5166 LOCK TWO RD. NEW BREMEN, OH  
419-753-3332

#19040

NOTE: WE WERE CONTRACTED TO PERFORM A RETRACEMENT SURVEY ON THE JOANNE C. LUTHMAN 79.63 AC. TRACT AS RECORDED IN INST. #201200001672. WE ABSTRACTED THE CHAIN OF TITLE BACK TO JAN. 23, 1856 WHEN ISHMAEL & MARTHA KEITH SOLD THE EAST HALF OF THE NORTHWEST QUARTER OF SEC. 1 TO WILLIE ANN BUNN (BRYAN?) IN DEED BOOK W PAGE 43. AT THAT TIME THE KEITHS ALSO OWNED THE WEST HALF OF THE NORTHWEST QUARTER OF SEC. 1. ON NOV. 2, 1859 THE KEITHS TRANSFERRED THE WEST HALF OF THE NORTHWEST QUARTER TO GREEN KEITH. IT APPEARS THAT THE EAST HALF OF THE NORTHWEST QUARTER OWNED BY JOANNE C. LUTHMAN IS THE SENIOR TRACT IN THE QUARTER SECTION. IT APPEARS FROM ANCIENT CORNER POST FOUND AT THE SOUTHEAST AND SOUTHWEST CORNERS OF THE PROPERTY AND OCCUPATION AT THE NORTHWEST CORNER OF THE QUARTER SECTION THAT AN EQUAL DIVISION WAS NOT CREATED, LEAVING THE EAST HALF SLIGHTLY SMALLER THAN THE WEST HALF, 81.220 ACRES VS. 80.961 ACRES. IT APPEARS THAT 20 CHAINS WAS CUT OF THE EAST HALF OF THE QUARTER SECTION WITHOUT SURVEYING THE ENTIRE TRACT. THE REASON BEHIND THE ADDITIONAL ACREAGE IN SAID QUARTER SECTION IS THAT ALL THE LINES OF SAID QUARTER SECTION MEASURE LONGER THAN A STANDARD QUARTER SECTION 40 CHAINS X 40 CHAINS (2640 FEET X 2640 FEET).

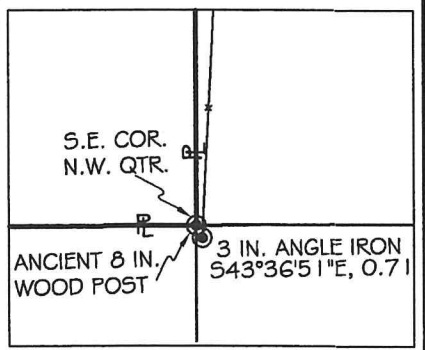
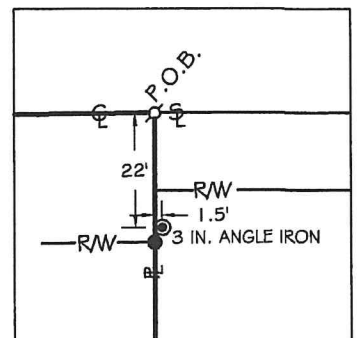
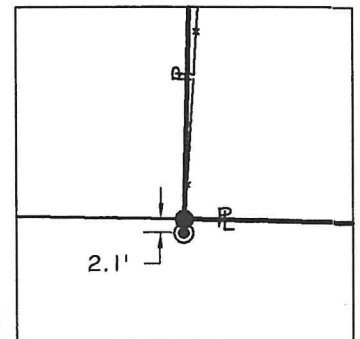

NOTE: THE BEARINGS CONTAINED HEREIN ARE BASED ON GPS OBSERVATIONS USING O.D.O.T. CORS NETWORK STATIONS, CONVERTED TO THE OHIO STATE PLANE NORTH ZONE, HORIZONTAL DATUM NAD83 (2011).

# DAHLINGHAUS SURVEY

PART OF THE W. 1/2 - S.E. 1/4 - SECTION 1, TOWN 7 SOUTH, RANGE 2 EAST, ( BUTLER TOWNSHIP ), MERCER COUNTY, OHIO.



PAUL & DONNA DAHLINGHAUS  
80 AC. (DEED)  
INST. # 2016-0177

REFERENCES:

- 1) ALBERS SURVEY BY G. GEESLIN, P.S. 5372, 7/25/91.
- 2) SOIL EVALUATION BY M. DEATON, 12/27/23, ON FILE WITH THE HEALTH DEPT.

Approved by the Mercer County Regional Planning Commission; no plat required under R.C. 711.133

1 Lot J.Weiss 2/21/24

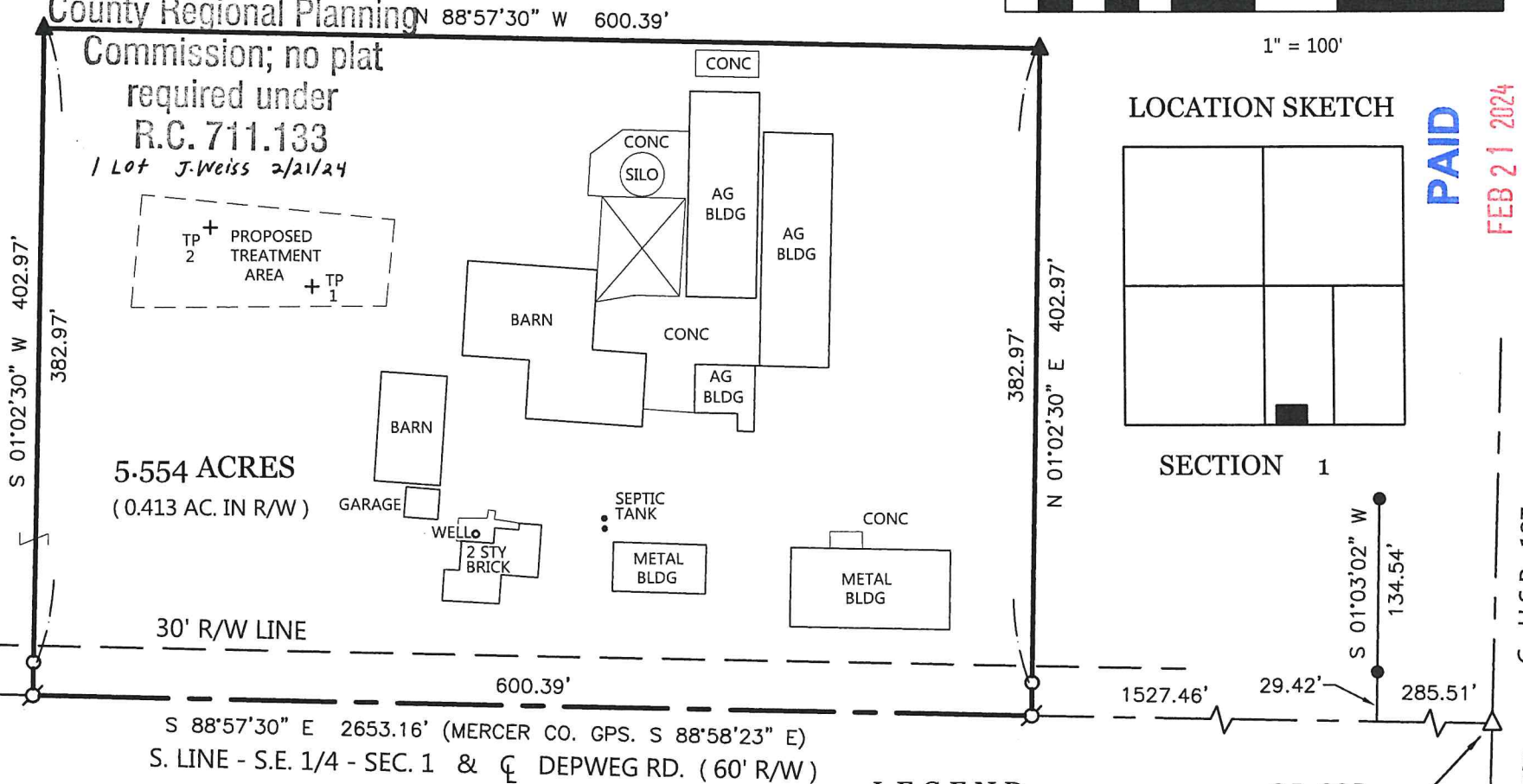

1" = 100'

### LOCATION SKETCH

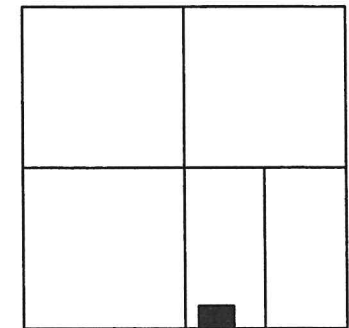

### SECTION 1

**PAID**  
FEB 21 2024

MERCER COUNTY COMMISSIONERS  
CELINA, OHIO

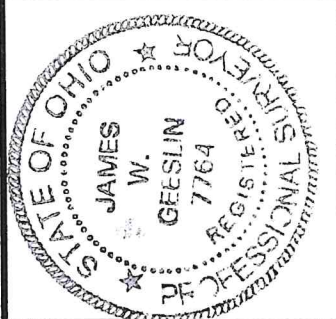

U.S.R. 127  
MERCER CO. HEALTH DISTRICT

### LEGEND

- △ = CALC. SECTION CORNER.
- ▲ = CALC. CORNER. NO MONUMENTATION SET @ REQUEST OF OWNER.
- = MAG NAIL FOUND.
- ⊙ = MAG SPIKE SET.
- = 5/8 INCH IRON BAR SET.

**PAID**  
FEB 20 2024

THIS PLAT REPRESENTS AN ACTUAL FIELD SURVEY PERFORMED UNDER MY SUPERVISION DATED FEBRUARY 14, 2024.

*James W. Geeslin*

ATTEST: JAMES W. GEESLIN  
PROFESSIONAL SURVEYOR 7764

PERMANENT PARCEL No.	Sec.	T.	R.	Area Retained	Acres
				Area Retained	Acres
Deed Reference:					
APPROVALS: <i>[Signature]</i> <i>[Signature]</i> <i>[Signature]</i>					
AGENCY: Board of Health					
DATE: 2-20-24					
Township Zoning Officer					
Mercer County Engineer					

## GEESLIN SURVEYING

525 S. SECOND ST.  
COLDWATER, OHIO 45828

Phone : (419) 678 - 7233  
Phone : (419) 678 - 7232 (cell)  
Email : jwgeeslinsurveyor@gmail.com

2-20-24