

N. LINE - N.W. 1/4 - SEC. 6 & $\frac{1}{4}$ SIEGRIST - JUTTE RD.
 N.W. COR. SEC. 6 \triangle N 89°55'02" W 3411.01' N.E. COR. - N.W. 1/4 - SEC. 6

LOCATION SKETCH

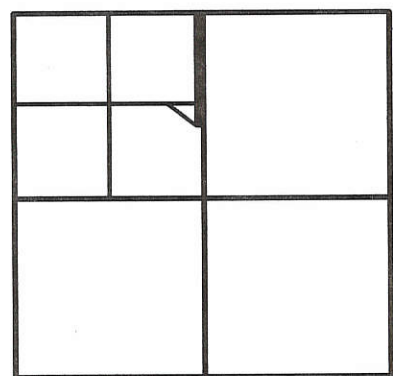

SECTION 6

SIEFRING SURVEY

PART OF THE N.W. 1/4 OF SECTION 6, TOWN 7 SOUTH, RANGE 2 EAST, (BUTLER TOWNSHIP), MERCER COUNTY, OHIO.

DECEMBER 8, 2004

SCALE 1" = 100'



SURVEYED BY

James W. Geeslin
JAMES W. GEESLIN
 P.S. No. 7764

N. LINE - S. 1/2 - N.W. 1/4 - SEC. 6
 N 89°59'04" W 336.71'

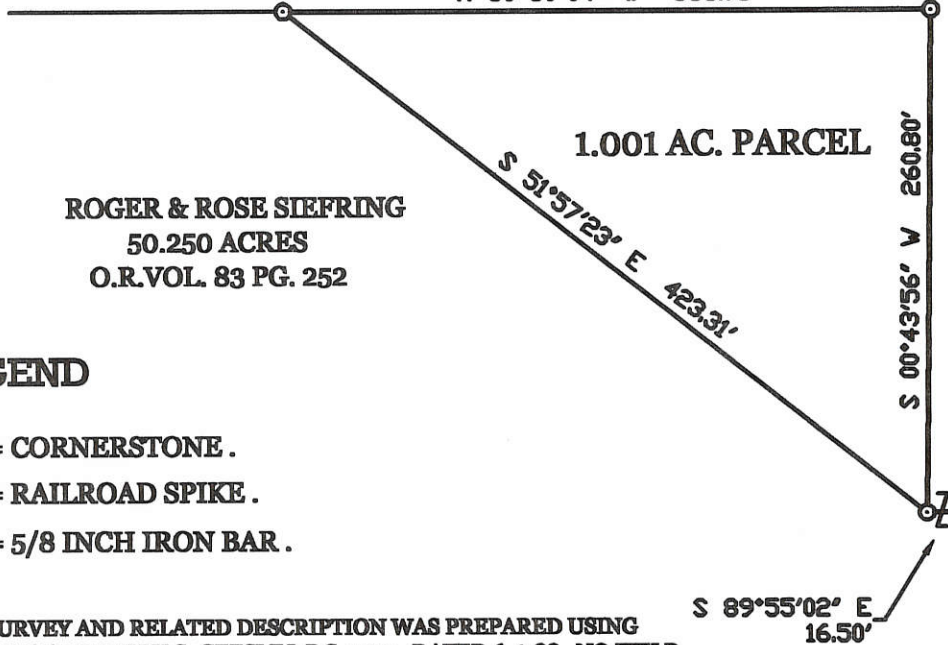

ROGER & ROSE SIEFRING
 50.250 ACRES
 O.R.VOL. 83 PG. 252

LEGEND

- \triangle = CORNERSTONE .
- \oslash = RAILROAD SPIKE .
- \odot = 5/8 INCH IRON BAR .

* THIS SURVEY AND RELATED DESCRIPTION WAS PREPARED USING THE ABELS SURVEY BY G. GEESLIN, P.S. 5372, DATED 6-4-88. NO FIELD WORK WAS PERFORMED.

GEESLIN LAND SURVEYING

P.O. BOX 422
 CELINA, OHIO 45822
 PHONE: (419) 586-6155
 FAX: (419) 678-9332



PERMANENT PARCEL No.	_____
Part of _____ Sec. _____ T. _____ R. _____ Township _____	
Grantor: _____	Area Retained: _____ Acres
Grantee: _____	Area Retained: _____ Acres
Deed References: _____	
APPROVALS AGENCY: _____	Board of Health: _____ Date: _____
	Township Zoning Officer: _____ Date: _____
	County Engineer: _____ Date: _____

1106200009

11-A(6)

NOTES :

- 1) REFER TO SURVEYS BY G. GEESLIN, P.S. 5372, DATED 12/14/89 & 6/2/89 .
- 2) REFER TO SOIL EVALUATION BY M. DEATON, 9/28/17. ON FILE IN THE MERCER CO. HEALTH DEPT.

THIS PLAT REPRESENTS AN ACTUAL FIELD SURVEY PERFORMED UNDER MY SUPERVISION, AS DATED HEREIN.

ATTEST: JAMES W. GEESLIN
PROFESSIONAL SURVEYOR 7764

N. 1/4 POST -
SEC. 6

N. LINE - N.E. 1/4 - SEC. 6 & SIEGRIST-JUTTE RD. (50' R/W)
S 88°36'21" E 2659.64' (BEARING BASED ON MER. CO. LOCAL GPS DATUM)

N.E. COR. -
SEC. 6

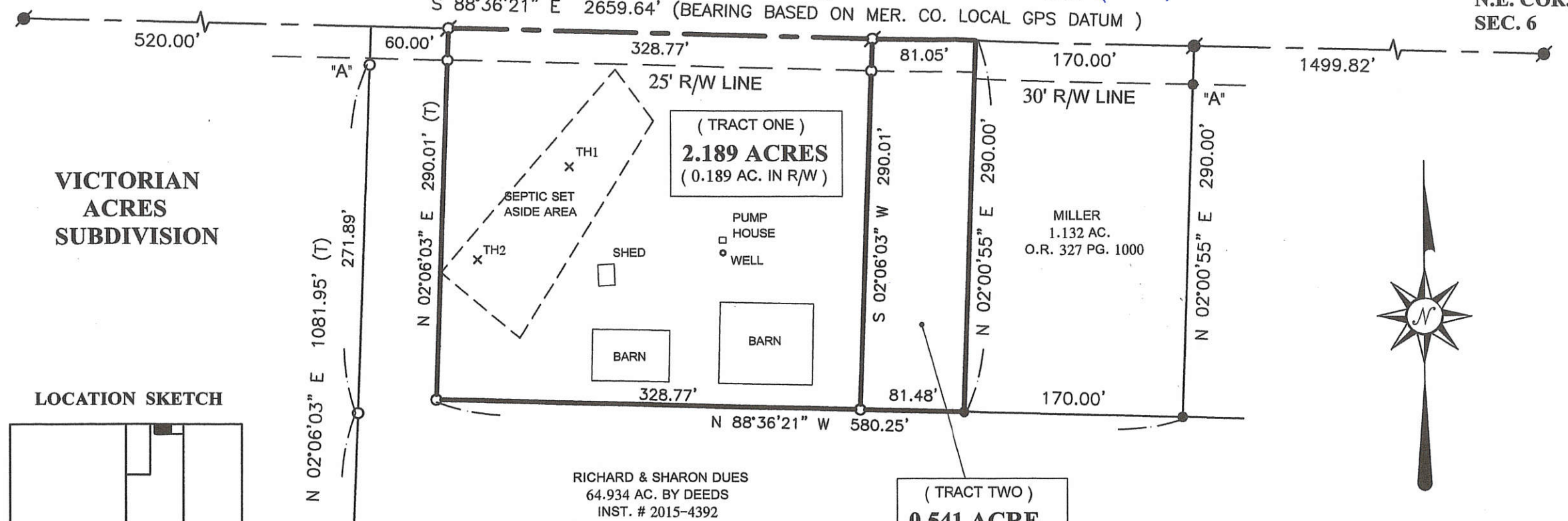

VICTORIAN
ACRES
SUBDIVISION

LOCATION SKETCH

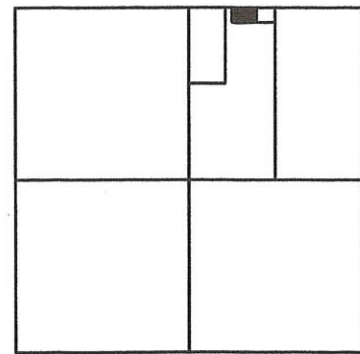

SECTION 6

RICHARD & SHARON DUES
64.934 AC. BY DEEDS
INST. # 2015-4392

(TRACT TWO)
0.541 ACRE
(0.047 AC. IN R/W)

Add To Parcel Only

DUES SURVEY

PART OF THE W. 1/2 OF THE N.E. 1/4 OF SECTION 6, TOWN
7 SOUTH, RANGE 2 EAST, (BUTLER TOWNSHIP), MERCER
COUNTY, OHIO.

NOVEMBER 16, 2017

SCALE 1" = 100'

PAID

NOV 29 2017

Mercer Co. Health Dept.



LEGEND

- = MAG NAIL FOUND .
- = 5/8 INCH IRON BAR FOUND .
- = 5/8 INCH IRON BAR SET .
- ⊙ = MAG NAIL SET .
- "A" = BAR SET OR FOUND @ 30.00' .

PAID

NOV 30 2017

\$200.00 - 1 Lot
MERCER COUNTY COMMISSIONERS
CELINA, OHIO

T. Nagel

1 Lot
Approved No Plat Required
For A Major Subdivision

Carl Miller 11/30/17
MINOR SUBDIVISION

PERMANENT PARCEL No.	_____
Part of: Sec. _____ T. _____ R. _____	Township _____
Grantor: _____	Area Retained: _____ Acres
Grantee: _____	Area Retained: _____ Acres
Deed References: _____	
APPROVALS: _____	Mercer County Engineer
AGENCY: _____	Township Zoning Officer
DATE: _____	_____

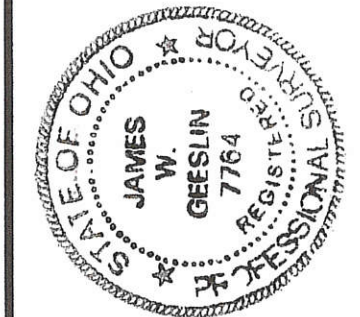

GEESLIN
LAND SURVEYING

525 S. SECOND ST.
COLDWATER, OHIO 45828

PHONE: (419)678-7233
geeslinsurveying@gmail.com

11-A ✓

11-6-200-005

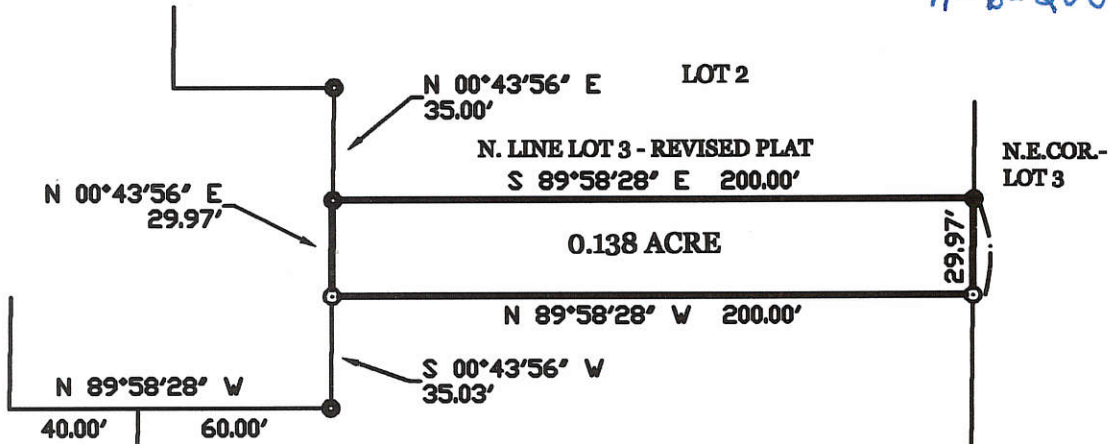

LEGEND

- ⊙ = CONCRETE MONUMENT FOUND.
- = 5/8 INCH IRON BAR FOUND.
- ⊙ = 5/8 INCH IRON BAR SET.

LOT 3
(3.098 ACRES REMAINING)

SURVEY OF OF A 0.138 ACRE STRIP OF LAND OFF THE NORTH END OF LOT 3 IN THE REVISED PLAT OF VICTORIAN ACRES SUBDIVISION, IN SEC. 6, BUTLER TOWNSHIP, MERCER COUNTY, OHIO.

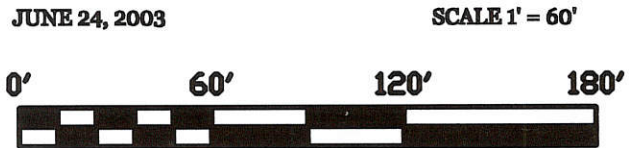

SURVEYED BY James W. Geeslin
JAMES W. GEESLIN
 P.S. No. 7764

N 87°52'52" W 260.05'

GEESLIN LAND SURVEYING

P.O. BOX 422
 CELINA, OHIO 45822
 PHONE: (419) 586-6155
 FAX: (419) 678-9332

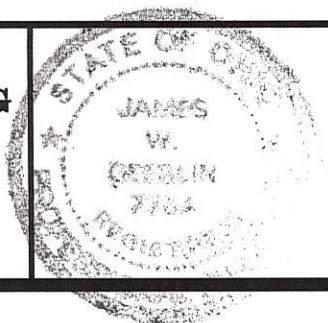

PERMANENT PARCEL No. _____			
Part of _____	Sec. _____	T. _____	R. _____ Township _____
Grantor: _____	Area Retained: _____	Acres: _____	
Grantee: _____	Area Retained: _____	Acres: _____	
Deed References: _____			
APPROVALS AGENCY: _____	Board of Health: _____ Date _____	Township Zoning Officer: _____ Date _____	County Engineer: _____ Date _____

PART LOT # 4 VICTORIAN ACRES SUBDIVISION
SEC. 6, T7S, R2E, BUTLER TOWNSHIP
MERCER COUNTY, OHIO AS REPLATTED

Co. Surv:

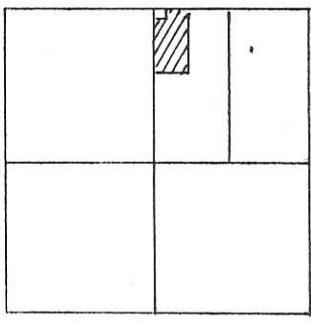

SEC 6 T7S R2E
BUTLER TWP.



SCALE 1" = 60'

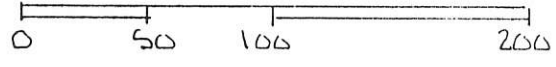

LEGEND-

- IRON PIN
- ◎ CONC. MON.

1106200016
1106200003

DEED REF. VOL. 313 PG. 879

REF. REPLAT VICTORIAN ACRES SUBDIVISION -
MERCER COUNTY RECORDERS OFFICE -

N.E. COR. LOT # 4

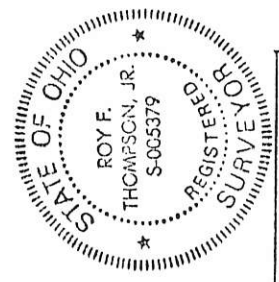
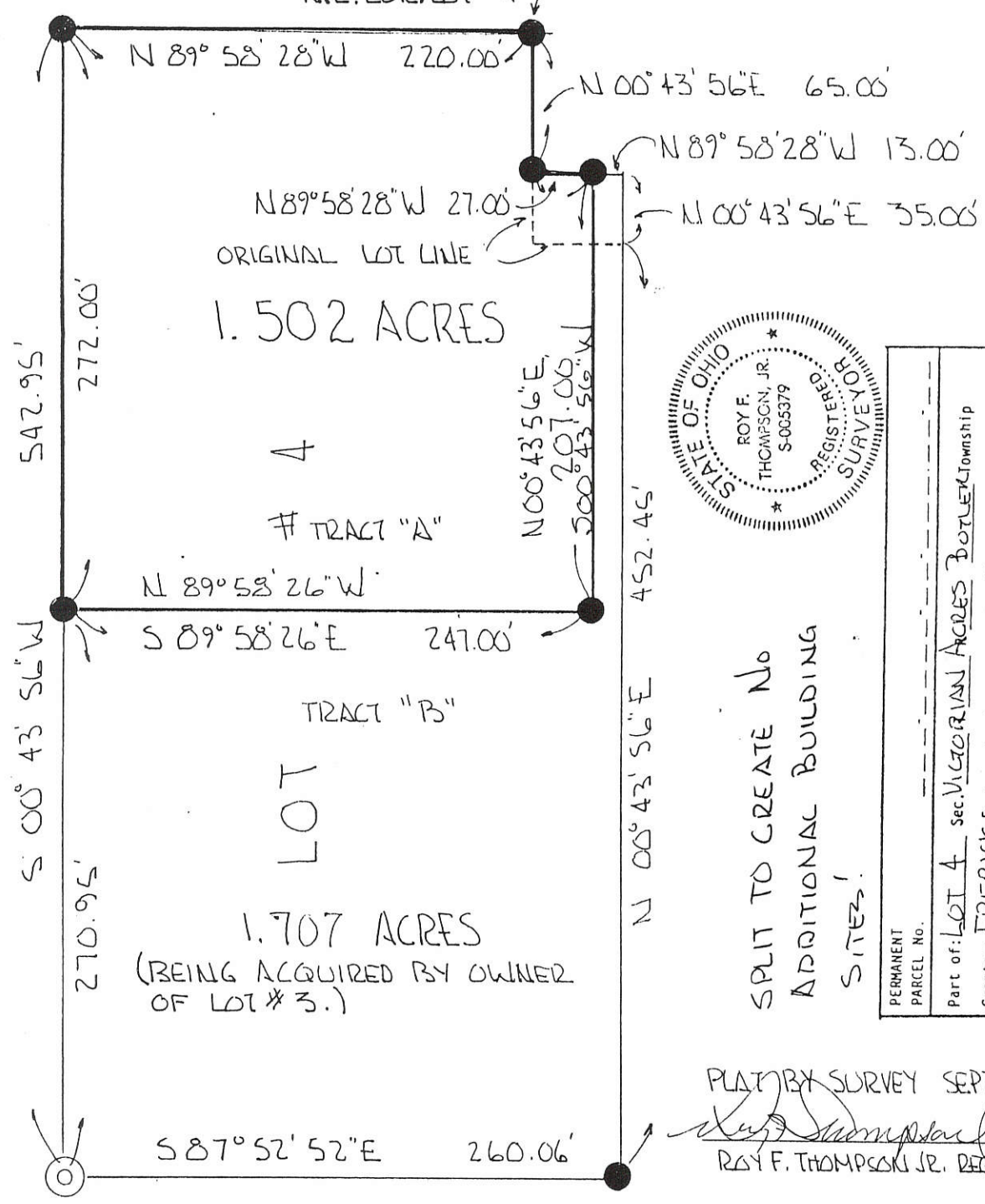

PERMANENT PARCEL No.	
Part of: LOT 4 Sec. VICTORIAN ACRES BUTLER Township	
Grantor: FERRICKS	Area Retained: 1.707 Acres
Grantee:	Area Transferred: 1.502 Acres
Deed References: Vol 313 Pg 879	
APPROVALS:	
AGENCY: Board of Health	Co. Sanitary Engineer
DATE: 31 OCT 96	County Engineer

PLAT BY SURVEY SEPT 1996 -

Roy F. Thompson, Jr.
ROY F. THOMPSON, JR., REG. SURV # 5379

LEGEND

- "A" = STONE AT N.W. COR. ~ N.E. 1/4 ~ SEC. 6.
- "B" = STONE AT N.E. COR. ~ SEC. 6.
- "C" = 5/8" IRON BAR AT CENTER ~ SEC. 6
- "D" = 1" IRON BAR FOUND 0.06' N. & 0.03' E. OF GILLIAND'S S.E. CORNER.
- "E" = 5/8" X 30" IRON BAR SET
- "F" = MINE SPIKE SET.
- "G" = PUNCH MARK ON N. EDGE OF RR. SPK. (FD)
- ⬡ = 1.5 ACRE TRACT OF LAND OWNED BY KEVIN AND JOAN GILLILAND SEE DEED VOL. 303, PG. 925.

LOCATION SKETCH

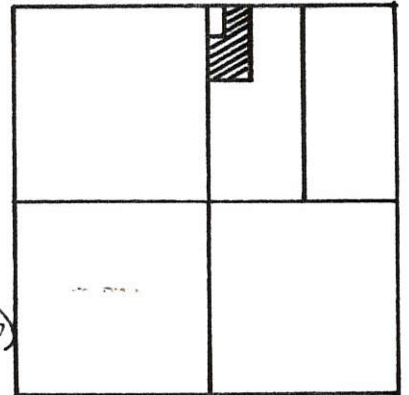

SECTION 6

N

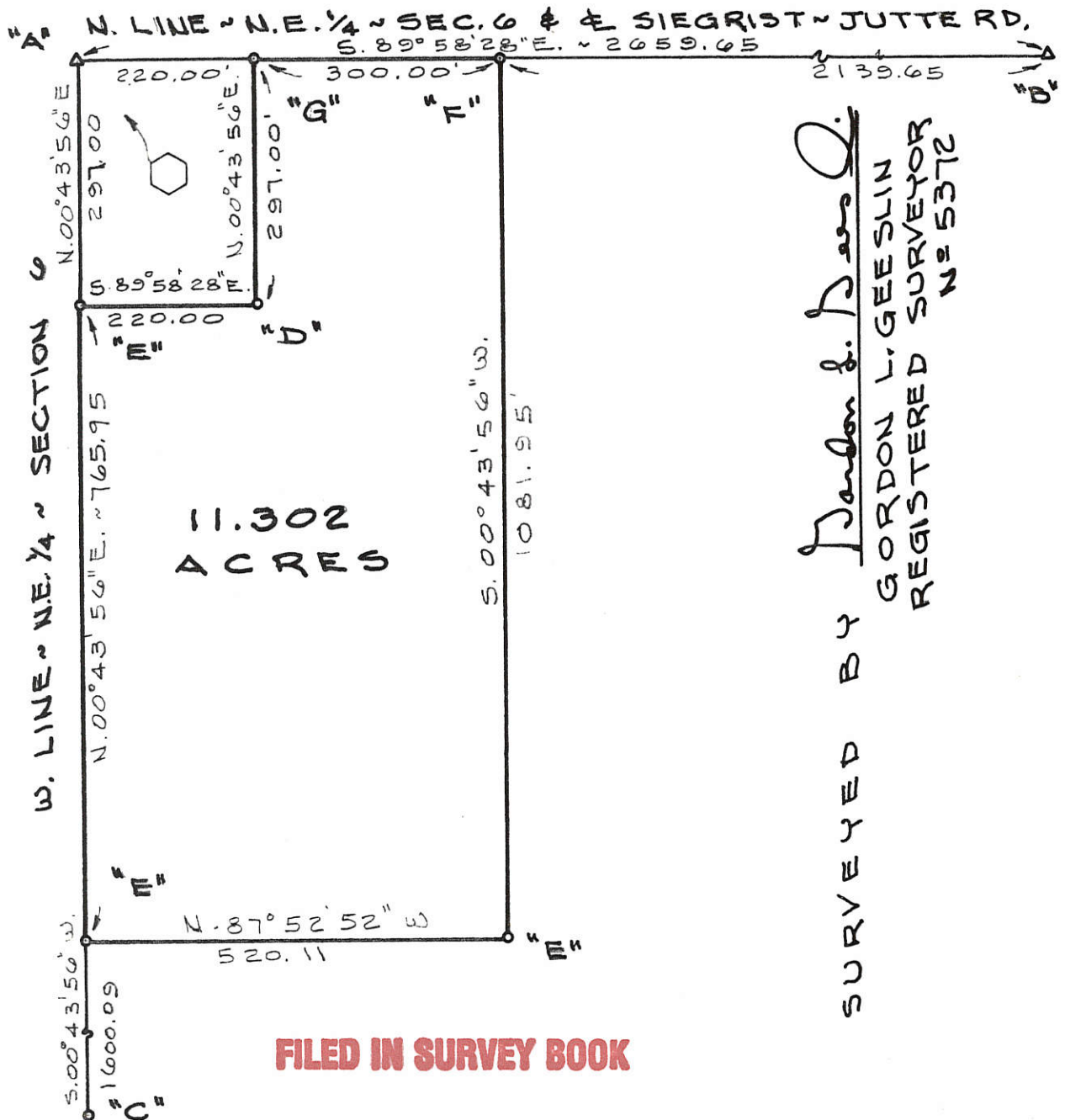

SURVEYED BY *Gordon L. Geeslin*
 GORDON L. GEESLIN
 REGISTERED SURVEYOR
 No. 5372

FILED IN SURVEY BOOK

EDGAR DUES SURVEY
 PART OF THE W. 1/2 OF THE NE. 1/4 OF SECTION 6, TOWN 7 SOUTH, RANGE 2 EAST (BUTLER TOWNSHIP), MERCER COUNTY, OHIO.

JUNE 2, 1989

SCALE 1" = 200

GORDON L. GEESLIN

LAND SURVEYOR
 810 EAST MARKET STREET
 CELINA, OHIO
 PHONE (419) 586-6155



PERMANENT PARCEL No. _____
Part of: _____ Sec. _____ T _____ R _____ Township
Grantor: _____ Area Retained: _____ Acres
Grantee: _____ Area Transferred: _____ Acres
Deed References: _____
APPROVALS: _____
AGENCY: _____
DATE: _____
Board of Health _____
County Sanitary Engineer _____
County Engineer _____

1106200008+
-007

MERCER Co,
ENGR, 11-A

LEGEND

- "A" = STONE NO 537 AT N.W. COR. ~ NE 1/4 ~ SECTION 6.
- "B" = STONE NO 536 AT N.E. COR. ~ SEC. 6.
- "C" = POINT AT S. 1/4 POST ~ N.E. 1/4 ~ SEC. 6.
(A CROSS TIE CORNER POST IS 0.8' WEST.)
- = MINE SPICK SET.
- o = 5/8" X 30" IRON BAR SET.

LOCATION SKETCH

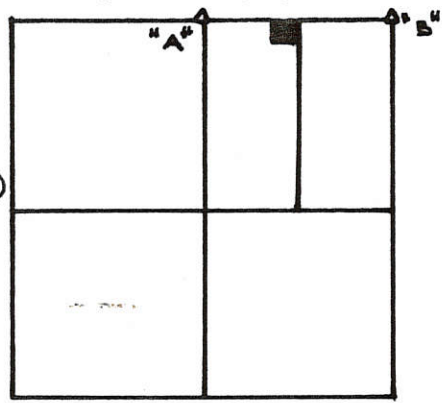

SURVEYED BY Gordon L. Geeslin SECTION 6
 GORDON L. GEESLIN
 REGISTERED SURVEYOR
 NO 5372

(THIS BEARING TAKEN FROM PRIOR SURVEY)

N. LINE ~ N. E. 1/4 ~ SEC. 6 & SIEGRIST-JUTTE RD.

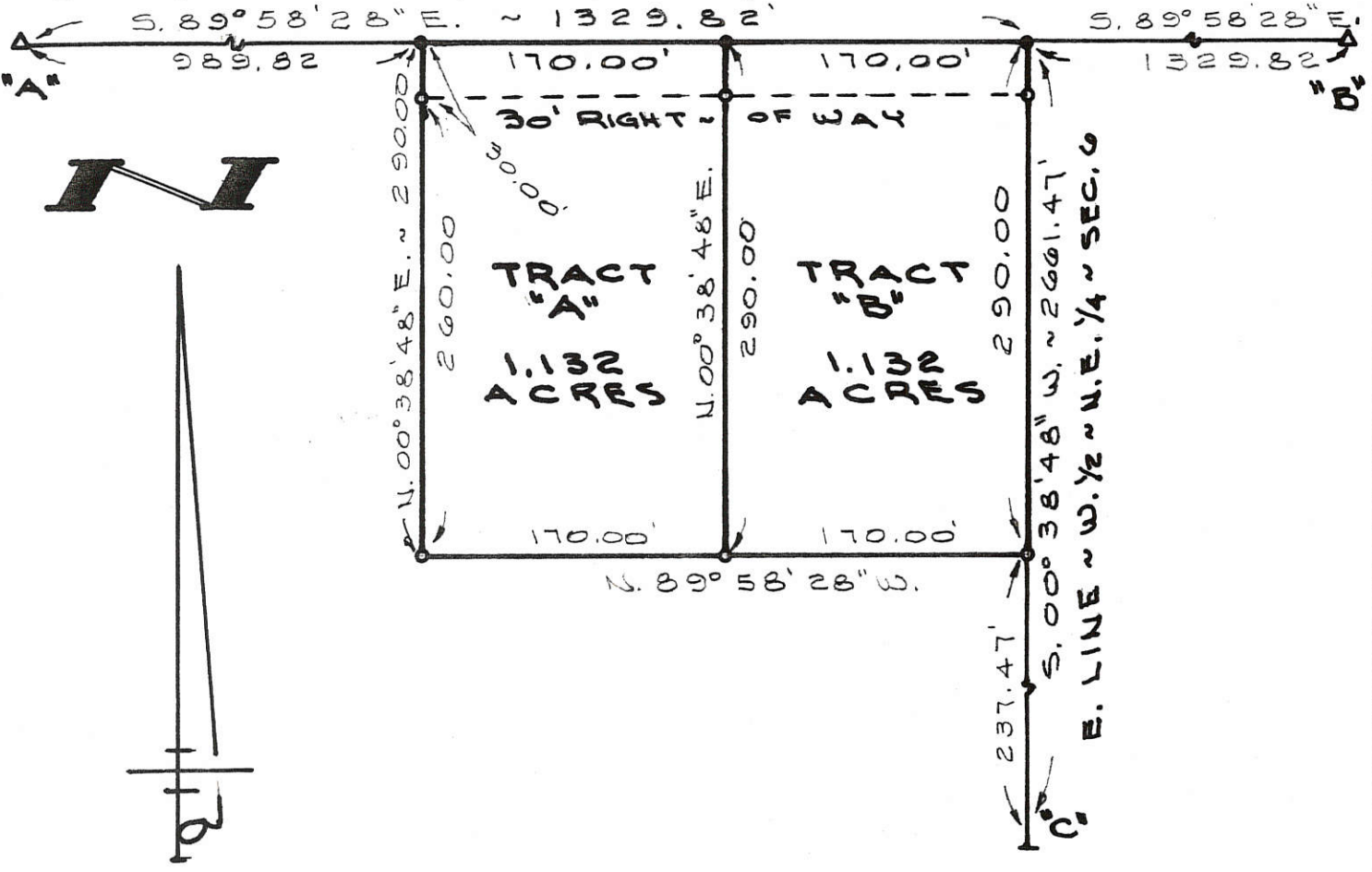

DUES SURVEY

PART OF THE W. 1/2 OF THE N.E. 1/4 OF SECTION 6,
 TOWN 7 SOUTH, RANGE 2 EAST (BUTLER
 TOWNSHIP), MERCER COUNTY, OHIO.

DECEMBER 14, 1989

SCALE 1" = 100'

FILED IN SURVEY BOOK



GORDON L. GEESLIN
 LAND SURVEYOR
 810 EAST MARKET STREET
 CELINA, OHIO
 PHONE (419) 586-6155

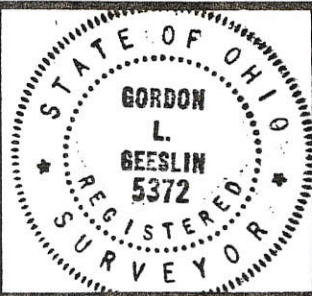

PERMANENT PARCEL No. _____

Part of: _____ Sec. _____ T. _____ R. _____ Township

Grantor: _____ Area Retained: _____ Acres

Grantee: _____ Area Transferred: _____ Acres

Deed References: _____

APPROVALS:
 AGENCY: _____ DATE: _____

Board of Health _____ County Sanitary Engineer _____ County Engineer _____

HOMAN SURVEY

1106300006

PART OF THE W. FRACTIONAL 1/2 OF SECTION 6, TOWN 7 SOUTH, RANGE 2 EAST, (BUTLER TOWNSHIP), MERCER COUNTY, OHIO.

NOVEMBER 4, 2016

SCALE 1" = 100'



LOCATION SKETCH

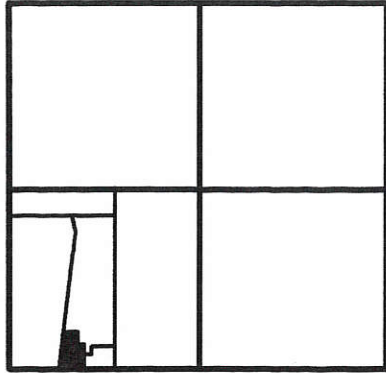

SECTION 6



ALBER & LINDA BRACKMAN
20 AC. BY DEED
INST. # 2014-4621

APPROXIMATE & OPEN DITCH
S 05°13'08" W 657.11'

5.001 TOTAL ACRES
(0.275 AC. IN R/W)

FRAME RESEIDENCE
SEPTIC TANK

WELL 42.0ft

AG BLDG.

AG BLDG.

N 88°35'29" W 114.20' (T)

N 88°10'44" W 179.88'

0.177 ACRE EASEMENT
AREA

4.739 ACRE PARCEL

Approved by the Mercer
County Regional Planning
Commission; no plat
required under
R.C. 711.133

1 Lot
Approved No Plat Required
For A Major Subdivision
Cue 12/12/16

MINOR SUBDIVISION

S.W. COR. -
SEC. 6

LEGEND

- △ = CORNERSTONE (REFER TO MERCER CO. STONE REC'S).
- ⊙ = RAILROAD SPIKE FOUND.
- = 5/8 INCH IRON BAR FOUND.
- = 5/8 INCH IRON BAR SET.

S 88°35'29" E 3346.07' (BEARING BASED ON MER. CO. LOCAL GPS DATUM)
S. LINE - W. FRACTIONAL 1/2 - SEC. 6 & PHILOTHEA RD. (60' R/W)

SURVEYED BY

James W. Geeslin
JAMES W. GEESLIN
P.S. No. 7764

SURVEY REFERENCES :

- 1) ABELS SURVEY BY G. GEESLIN, P.S. 5372, 6-14-88.
- 2) PRIOR SURVEY FOR HOMAN DATED 7/18/11

PAID

PAID

DEC 01 2016

DEC 00 2015

20 Dec

MERCER COUNTY COMMISSIONERS
MERCER CO. Health Dept.

MERCER COUNTY COMMISSIONERS
GELINA, OHIO

PERMANENT
PARCEL No.

Part of: _____ Sec. _____ T _____ R _____ Township
Grantor: _____ Area Retained: _____ Acres
Grantee: _____ Area Transferred: _____ Acres

Deed References: _____

APPROVALS: _____
AGENCY: _____
DATE: _____
TOWNSHIP ZONING OFFICER: _____
COUNTY ENGINEER: _____
DATE: 12-8-16



GEESLIN
LAND SURVEYING

525 S. SECOND ST.
COLDWATER, OHIO 45828
PHONE (419) 678-7232

11-A(6)

110630003

LEGEND

- △ = CORNERSTONE (REFER TO MER. CO. STONE REC'S).
- = RAILROAD SPIKE FOUND.
- = RAILROAD SPIKE SET.
- ⊙ = 5/8 INCH IRON BAR SET.

REFER TO ABELS SURVEY BY G. GEESLIN, P.S. 5372, JUNE 14, 1988

SURVEYED BY

James W. Geeslin
JAMES W. GEESLIN
 P.S. No. 7764

JANICE BROERING
 O.R. VOL. 47 PG. 01
 51.138 AC. BY DEED

* REFER TO RESIDENTIAL SEWAGE TREATMENT SYSTEM SOIL EVALUATION BY FREDRICK SCHOEN, P.E., 7-13-2011. X ON PLAT REPRESENT TEST PITS.

* POINTS SET NORTH OF ϕ ARE SET @ 25.00'



LOCATION SKETCH

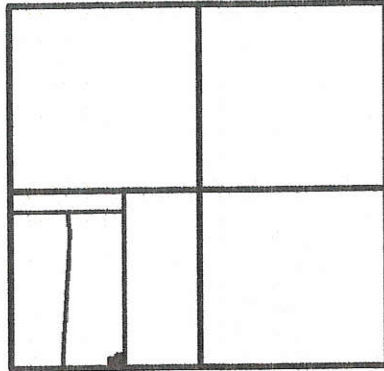

SECTION 6

1 Lot
MINOR SUBDIVISION
Carl Miller 7/28/11
 Approved No Plat Required
 For A Major Subdivision

ROGER & MARY LOU HOMAN
 D.V. 312 PG. 306
 45.788 AC. BY DEED

AGRICULTURAL BLDG.
 SITS 5' INSIDE PROPERTY LINES

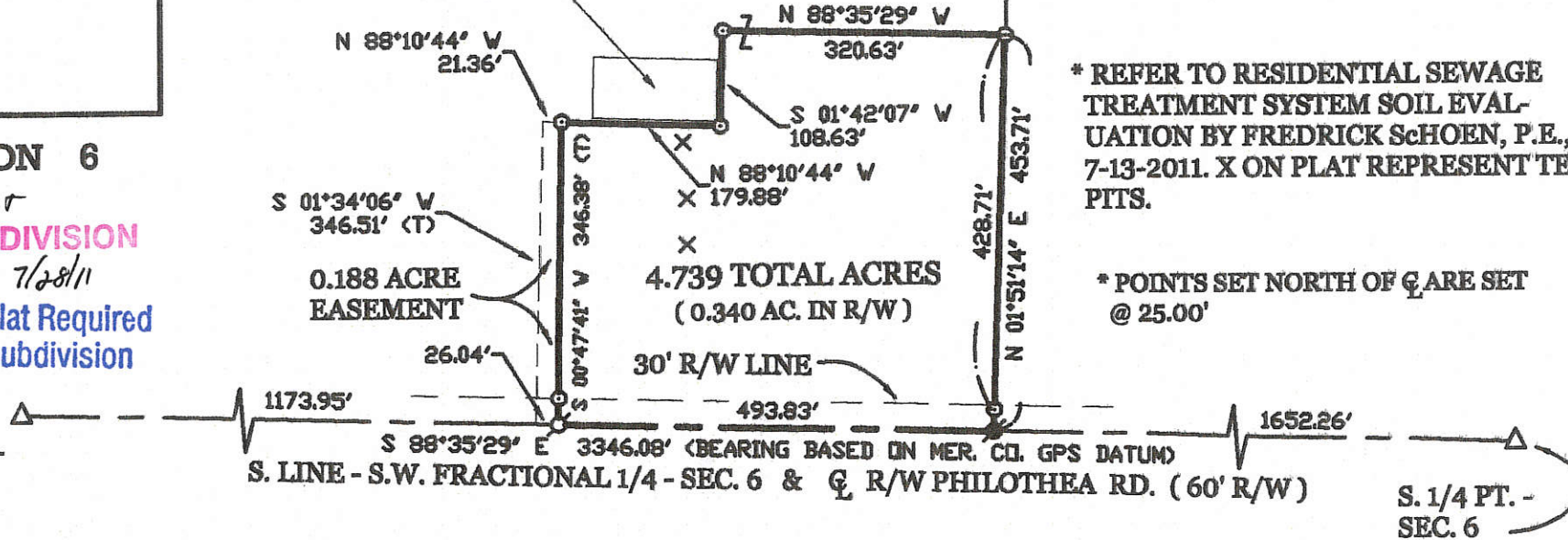

HOMAN SURVEY

PART OF THE WEST FRACTIONAL HALF OF SECTION 6, TOWNSHIP 7 SOUTH, RANGE 2 EAST, (BUTLER TOWNSHIP), MERCER COUNTY, OHIO.

JULY 18, 2011



SCALE 1" = 200'

PERMANENT PARCEL No.

Part of _____ Township
 Quarter _____ Acres
 Grantor _____ Acres
 Recd References _____

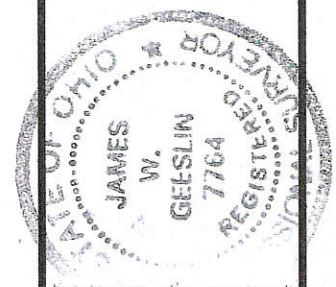

GEESLIN
LAND SURVEYING

525 S. SECOND ST.
 COLDWATER, OHIO 45828
 PHONE: (419) 678-7232

APPROVALS:	Date:
AGENCY	
Board of Health	7-27-11
Township Zoning Officer	
County Engineer	7-22-11

11-A(6)

1105300005
 1106300001
 1106300002

HOMAN SURVEY

PART OF THE W. 1/2 - S.W. 1/4 - SECTION 6, TOWNSHIP 7 SOUTH, RANGE 2 EAST, (BUTLER TOWNSHIP),
 MERCER COUNTY, OHIO .

SEPTEMBER 17, 2014

E. 1/4 POST -
 SEC. 1
 (RECOVERY TWP.)

ROMAN SAALMAN
 VOL. 266 PG. 402 & VOL. 282 PG. 794
 161.7 ACRES

W. 1/4 POST -
 SEC. 6

LOCATION SKETCH

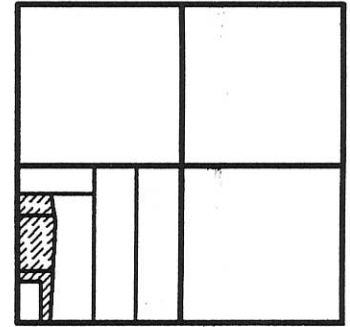

SECTION 6

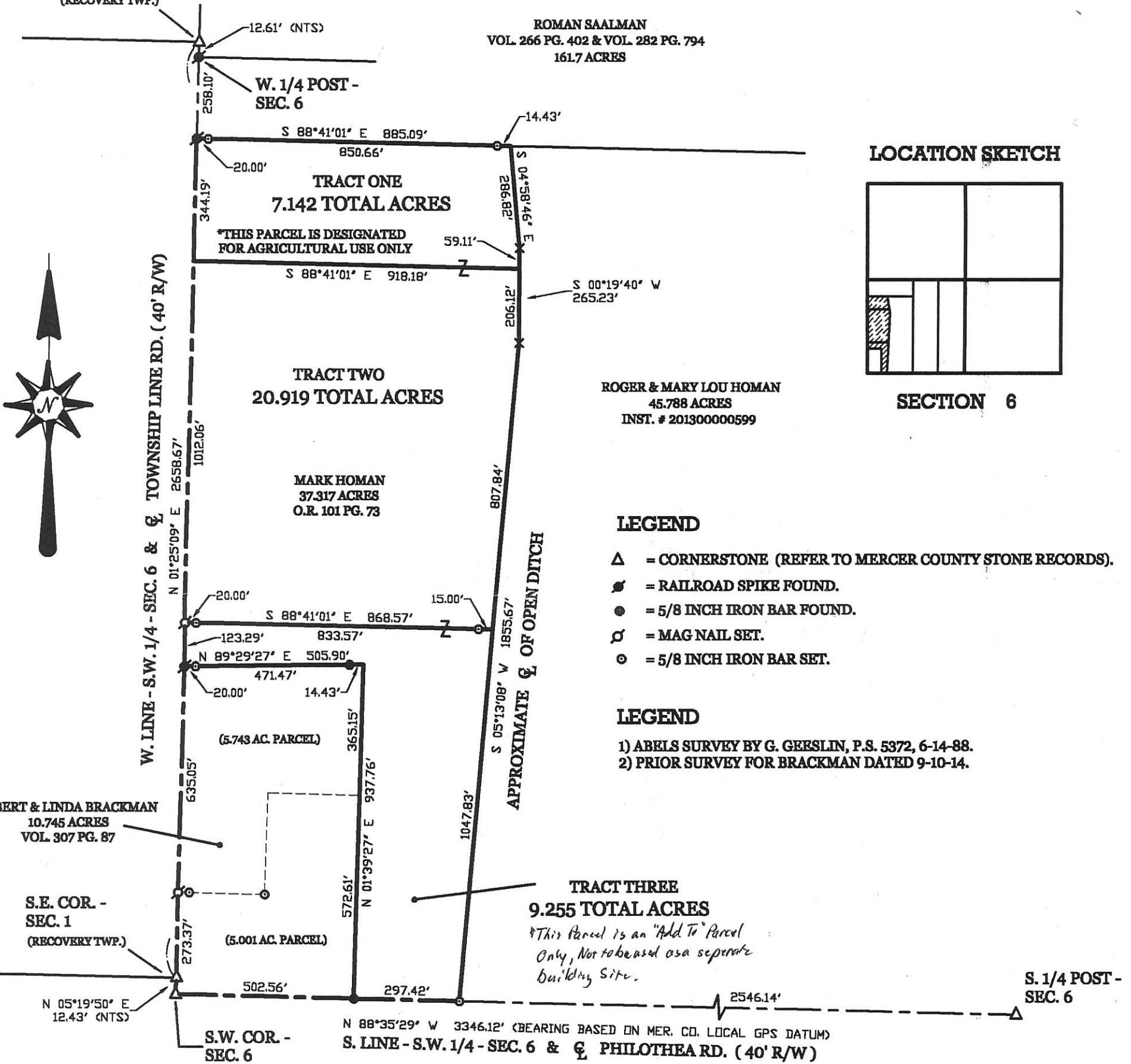

SCALE 1" = 200'

**GEESLIN
 LAND SURVEYING**
 525 S. SECOND ST.
 COLDWATER, OHIO 45828
 PHONE (419) 678-7232



SURVEYED BY *James W. Geeslin*
 JAMES W. GEESLIN
 P.S. No. 7764

11-A(6)

110630002

W. 1/4 POST - SEC. 6

BRACKMAN SURVEY

PART OF THE W. 1/2 - S.W. 1/4 SECTION 6, TOWNSHIP 7 SOUTH, RANGE 2 EAST, (BUTLER TOWNSHIP), MERCER COUNTY, OHIO.

SEPTEMBER 10, 2014

SCALE 1" = 100'



1 Lot (Tract Two)
Approved by Mercer County Regional Planning Commission; No Approval or Plat Required under R.C. 711.133; FOR AGRICULTURAL AND PERSONAL RECREATIONAL USE ONLY.
C. G. H. 9/22/14

W. LINE - S.W. 1/4 - SEC. 6 & TOWNSHIP LINE RD. (40' R/W)

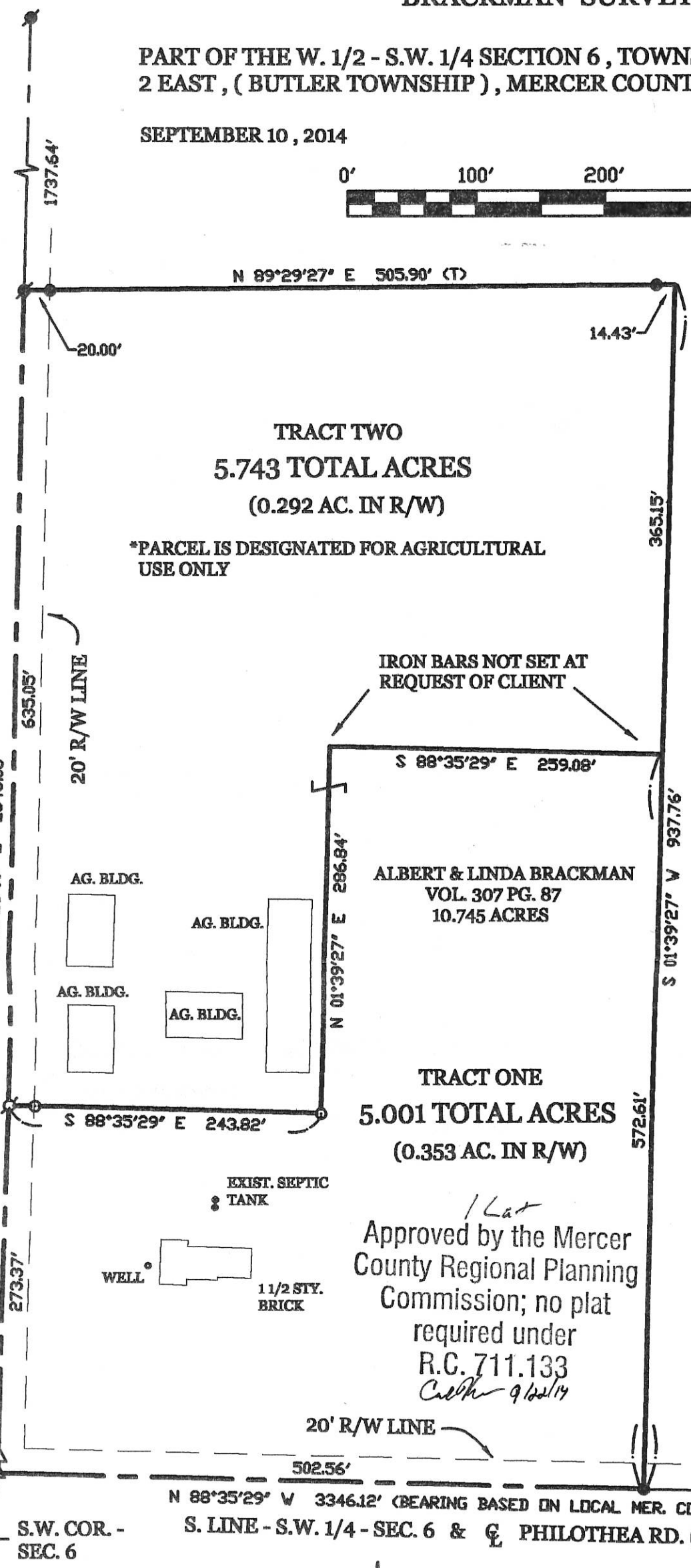

MARK HOMAN
O.R. 101 PG. 73
37.317 ACRES

LEGEND

- △ = CORNERSTONE.
- = MAG NAIL SET.
- = R.R. SPIKE FOUND.
- = 5/8 INCH IRON BAR FOUND.
- = 5/8 INCH IRON BAR SET.

LOCATION SKETCH

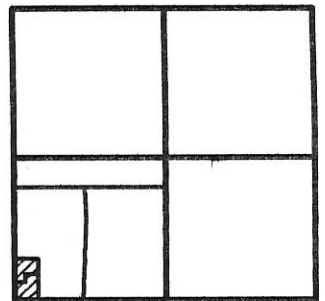

SECTION 6

S.E. COR. - SEC. 1 (RECOVERY TWP.)

1 Lot
Approved by the Mercer County Regional Planning Commission; no plat required under R.C. 711.133
C. G. H. 9/22/14

S. 1/4 POST - SEC. 6

SURVEYED BY

James W. Geeslin
JAMES W. GEESLIN
P.S. No. 7764

* REFER TO ABELS SURVEY BY G. GEESLIN , P.S. 5372 , 6/14/88.

GEESLIN LAND SURVEYING

525 S. SECOND ST.
COLDWATER, OHIO 45828
PHONE (419) 678-7232



PERMANENT PARCEL No.	_____		
Part of:	Sec. _____	T. _____	R. _____ Township _____
Grantor:	_____ Area Retained: _____ Acres		
Grantee:	_____ Area Transferred: _____ Acres		
Deed References:	_____		
APPROVALS:	<i>[Signature]</i>	<i>[Signature]</i>	<i>[Signature]</i>
AGENCY:	Board of Health	Township Zoning Officer	County Engineer
DATE:	9-19-14	9-11-14	9-16-14

11-A(6)

SURVEY OF A 1.122 AC. TRACT FOR ROGER SIEFRING
LOCATED IN THE FRACT. S.W. 1/4 OF SEC. 06, T-7-S,
R-2-E, BUTLER TWP., MERCER COUNTY, STATE OF OHIO

1106400001

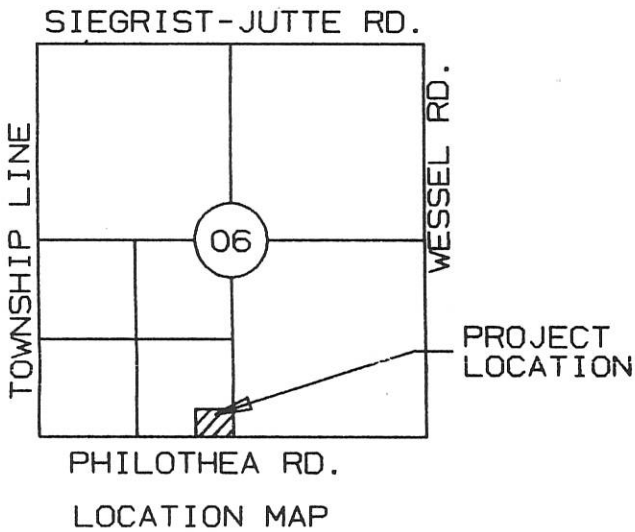

CENTER OF SEC. 06
IRON PIN FOUND

ROGER & ROSE SIEFRING

Vol. 207, Pg. 346

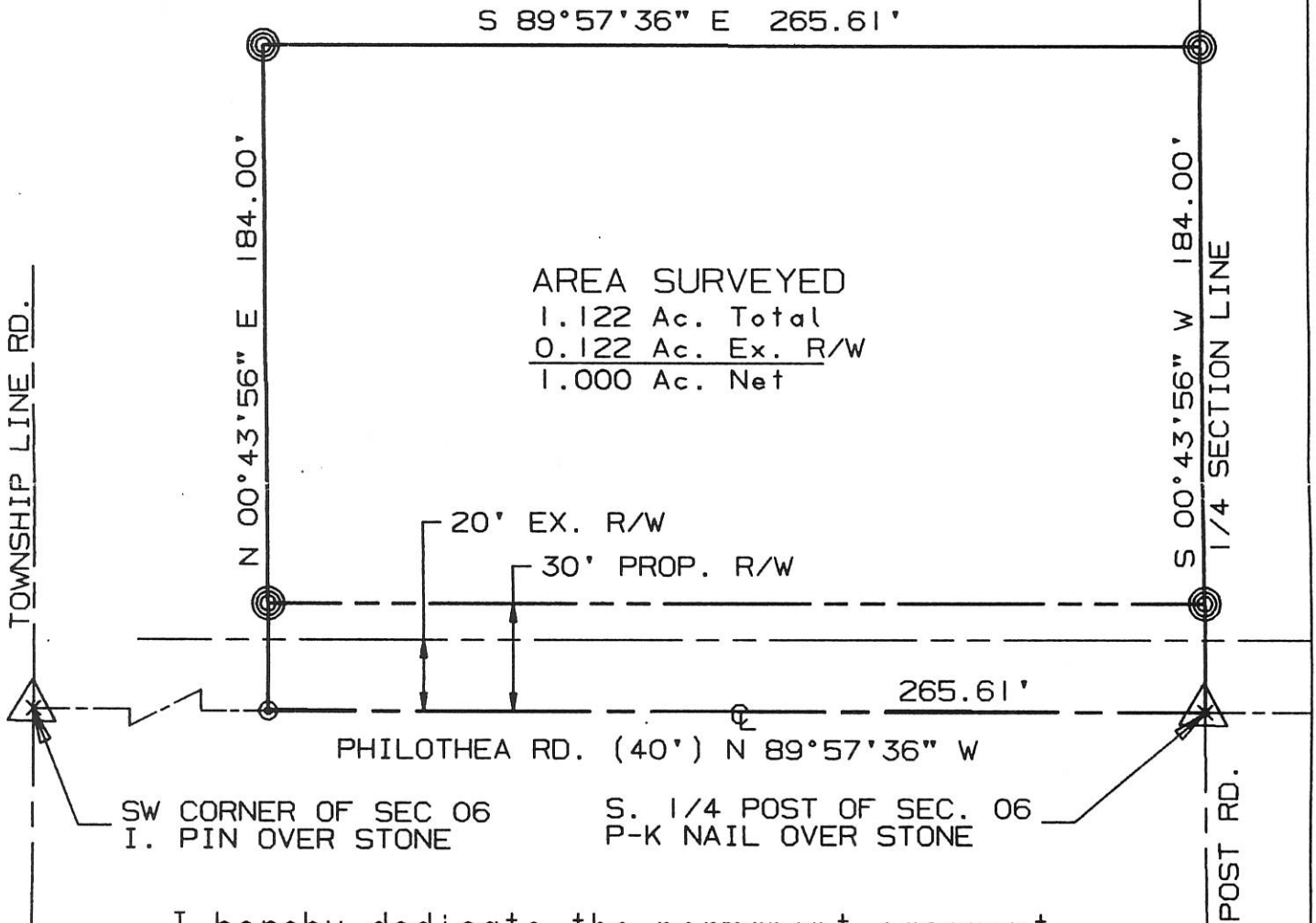

AREA SURVEYED
 1.122 Ac. Total
 0.122 Ac. Ex. R/W
 1.000 Ac. Net

I hereby dedicate the permanent easement
for roadway purposes as shown on this plat.

Roger F. Siefring
ROGER F. SIEFRING

Rose Ann Siefring
ROSE ANN SIEFRING

SURVEYED BY: *Eric C. Thomas*
ERIC C THOMAS REG. SURVEYOR #7236
DATE: 09-27-96

⊙ = P-K NAIL SET
⊗ = I. PIN SET



References: PREVIOUS SURVEY A OF THIS SECTION BY GORDEN GEESLIN REG. SURVEYOR #5372 DATED 6-14-88		Scale 1"=50' 0 25 50 100	
Part of S.W. 1/4 Sec. 06 T-7-S R-2-E BUTLER Twp., MERCER Co., OHIO			
GRANTOR: R. SIEFRING DEEDS: Vol. 207 Pg. 346 AREA RETAINED _____ Ac.			
GRANTEE: _____ AREA: _____ Ac.			
APPROVALS:	_____	_____	_____
AGENCY: BD. OF HEALTH	Co. San. Eng.	Co. Engineer	PERMANENT PARCEL No.
DATE			

SURVEY OF A 13.611 ACRE PARCEL & A 20.618 ACRE PARCEL FOR ROGER SIEFRING

LOCATED IN THE S.E. 1/4 OF SEC. 6, T-7-S, R-2-E,
BUTLER TWP., MERCER CO., OHIO

110640006
110640007

DONALD & MADONNA KREMER
Vol. 258 Pg. 738

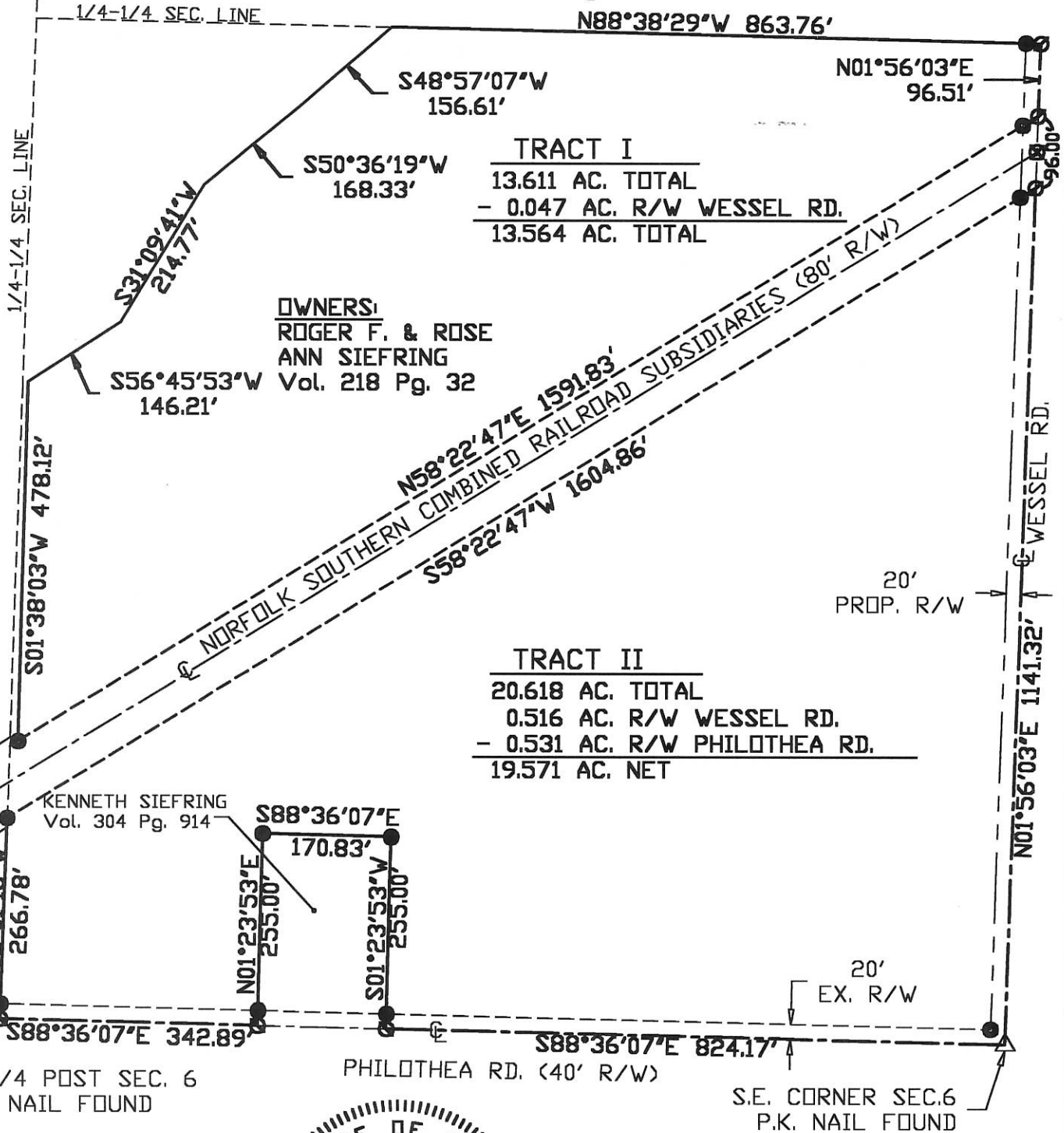

TRACT I
13.611 AC. TOTAL
- 0.047 AC. R/W WESSEL RD.
13.564 AC. TOTAL

OWNERS:
ROGER F. & ROSE
ANN SIEFRING
Vol. 218 Pg. 32

TRACT II
20.618 AC. TOTAL
0.516 AC. R/W WESSEL RD.
- 0.531 AC. R/W PHILOTHEA RD.
19.571 AC. NET

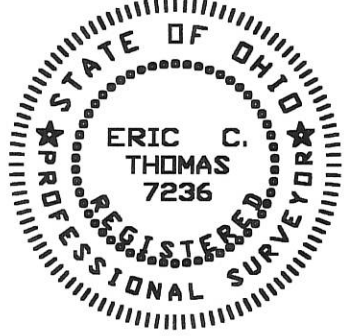
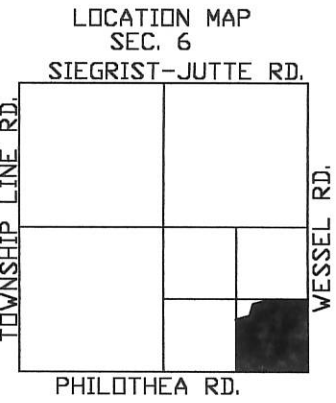
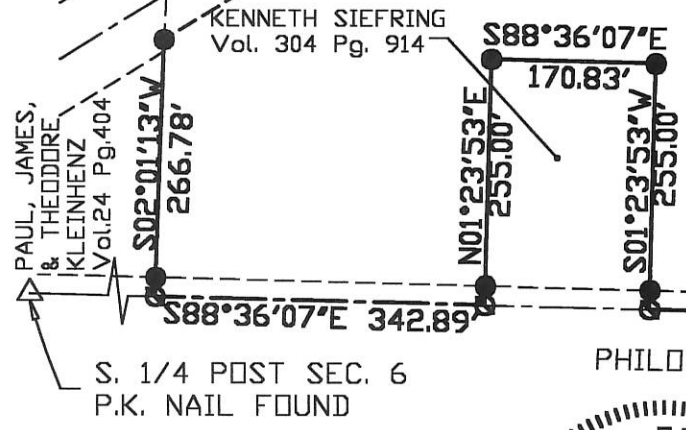

NOTE:
THE COUNTY ENGINEERS
OFFICE HAS NO RIGHT-
OF-WAY INFORMATION ON
FILE FOR THIS PORTION
OF WESSEL ROAD.



Surveyed By: *Eric C. Thomas*
Eric C. Thomas Reg. Surveyor No. 7236
Date: 03-26-99

- Iron Pin Set
- P.K. NAIL SET
- P.K. NAIL FOUND

References: G.P.S. OF SECTION STONES	Scale: 1" = 200'
Part of <u>S.E. 1/4 Sec. 6</u> T- <u>7-S</u> R- <u>2-E</u> <u>BUTLER</u> Twp., Mercer Co., OH	
Grantor: _____ Deeds: _____ Area Retained _____ Ac.	
Grantee: _____ Area _____ Ac.	
Approvals: Agency: Bd. of Health Date: _____	Co. San. En. _____ Co. Engineer _____ Permanent Parcel No. _____

110630001 to 006
110610003

LOCATION SKETCH

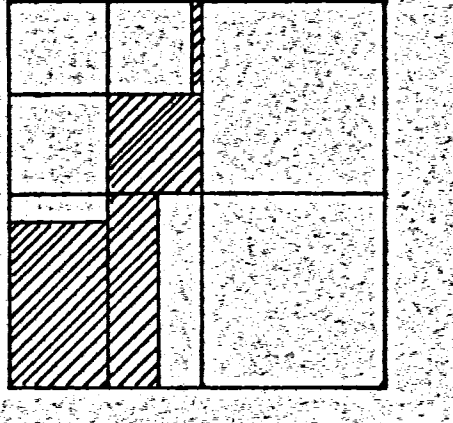

LEGEND

- ✓ "A" = STONE FD. BY THIS SURVEY AT S.W. CORNER 1/4 SEC. 6.
- ✓ "B" = STONE NO 245 AT S.E. COR. SEC. 1, RECOVERY TWP. (LISTED AS BEING AT S.W. COR. SEC. 6 - BUTLER)
- ✓ "C" = MINE SPIKE SET AT W. 1/2 POST SEC. 6
- ✓ "D" = STONE NO 133 AT E. 1/2 POST SEC. 1 - RECOVERY TWP.
- ✓ "E" = STONE NO 131 AT N.W. COR. SEC. 6 SECTION 6
- ✓ "F" = STONE NO 537 AT NE. COR. N.W. 1/4 SEC. 6
- ✓ "G" = STONE NO 536 AT NE. COR. SEC. 6
- ✓ "H" = STONE NO 488 AT S.E. COR. SEC. 6
- ✓ "I" = STONE FD. BY THIS SURVEY AT S.E. COR. N.W. 1/4 SEC. 6
- ✓ "J" = MINE SPIKE SET.
- ✓ "K" = RAILROAD DATE NAIL 1/2 3/4 SET IN BRIDGE DECK (1.0 ± NORTH OF SOUTH GUARD RAIL)
- ✓ "L" = 5/8" X 30" IRON BAR SET.
- ✓ "M" = 8" STEEL FENCE POST FOUND TO BE 0.4' N. OF CORNER AND 1.1' EAST OF CORNER. (ALL CALLS ARE TO CORNER.)

NOTES

- 1) THE WEST LINE OF THE NORTHWEST FRACTIONAL QUARTER OF SECTION 6 WAS ASSUMED TO BEAR NORTH - SOUTH. ALL OTHER BEARINGS WERE CALCULATED FROM ANGLES TURNED.
- 2) THE 12.61' OFFSET AT THE W. 1/2 POST IS BASED ON A DIRECT PROPORTION COMPARING THE MEASURED DISTANCE TO THE DISTANCE IN THE ORIGINAL NOTES 1819.
- 3) REFERENCE IS MADE A SURVEY OF SEC. 1 - RECOVERY TWP BY MARCUS SCHUYLER DATED OCT. 23, 1860, RECORDED IN SURVEY BOOK 1, PG. 159; A SURVEY BY SCHUYLER DATED AUG. 2, 1864, RECORDED IN SURVEY BOOK 1, PG. 206, OF SECTION 5, BUTLER TWP AND A SURVEY OF S.E. 1/4 SEC. 6, BUTLER TWP; RECORDED IN SURVEY BOOK 2, PAGE 221.
- * 4) THE LINE OF OCCUPANCY IS NORTH OF THE LINE OF RECORD BY 12.61' AT THE WEST END AND BY 6.31' AT THE EAST END. THE POSSIBILITY OF TITLE BY ADVERSE POSSESSION EXIST.
- * 5) THE LINE OF OCCUPANCY IS 10.5' ± EAST OF THE LINE OF RECORD. THIS IS APPARENTLY DUE TO A SCRIBER'S ERROR IN DEED FROM BERNARD BLEIMAN TO JOHN ABELS DATED MARCH 17, 1860 (SEE DEED VOL. 2, PG. 302) AND CARRIED THROUGH BY SUBSEQUENT TRANSFERS. THE POSSIBILITY OF TITLE BY ADVERSE POSSESSION EXIST.
- * 6) THE LINE OF OCCUPANCY IS 3.5' ± EAST OF THE LINE OF RECORD. THE POSSIBILITY OF TITLE BY ADVERSE POSSESSION EXIST.

SURVEYED BY Gordon L. Geeslin
GORDON L. GEESLIN
REGISTERED SURVEYOR
NO 5372

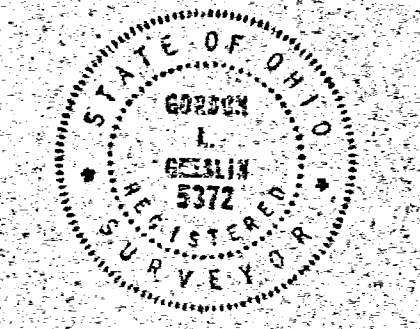

ABELS SURVEY
PART OF THE WEST FRACTIONAL HALF OF SECTION 6, TOWNSHIP 7 SOUTH, RANGE 2 EAST (BUTLER TWP.), MERCER COUNTY, OHIO.

JUNE 14, 1988

SCALE 1" = 300'

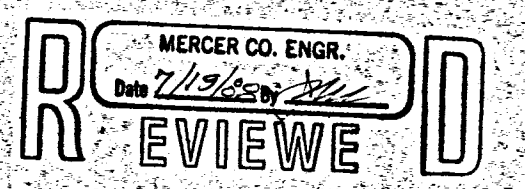
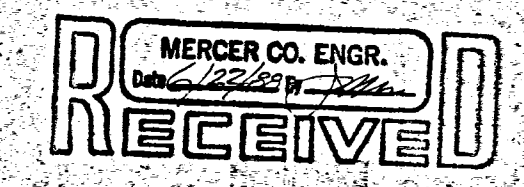

* NEW APP. COAR. 6/22/88

REVISED 6/22/88

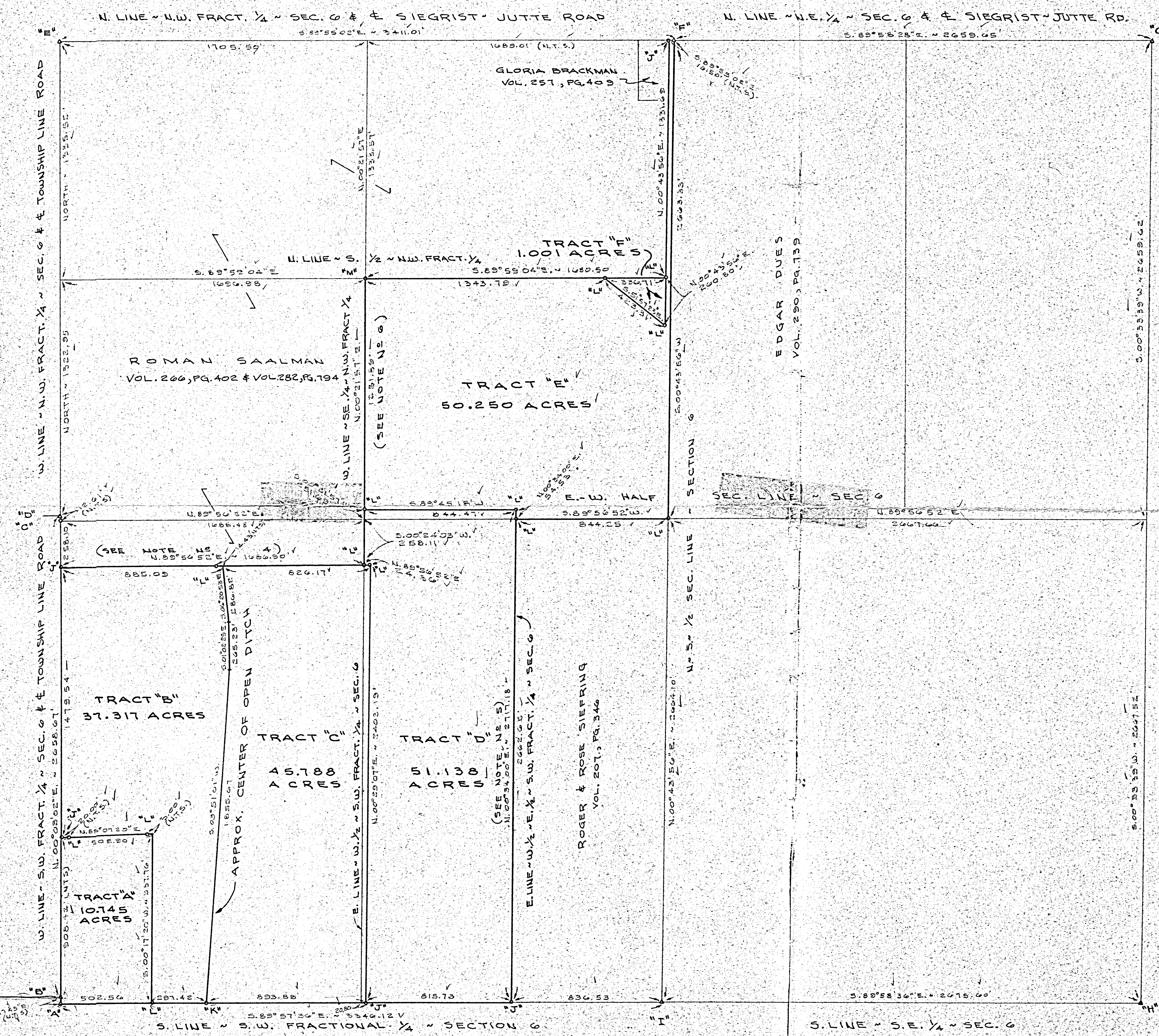

THIS PLAT REPRESENTS AN ACTUAL FIELD SURVEY PERFORMED UNDER MY SUPERVISION, AS DATED HEREIN.

ATTEST: JAMES W. GEESLIN
PROFESSIONAL SURVEYOR 7764

(BEARING BASED ON MERCER CO. LOCAL GPS DATUM)

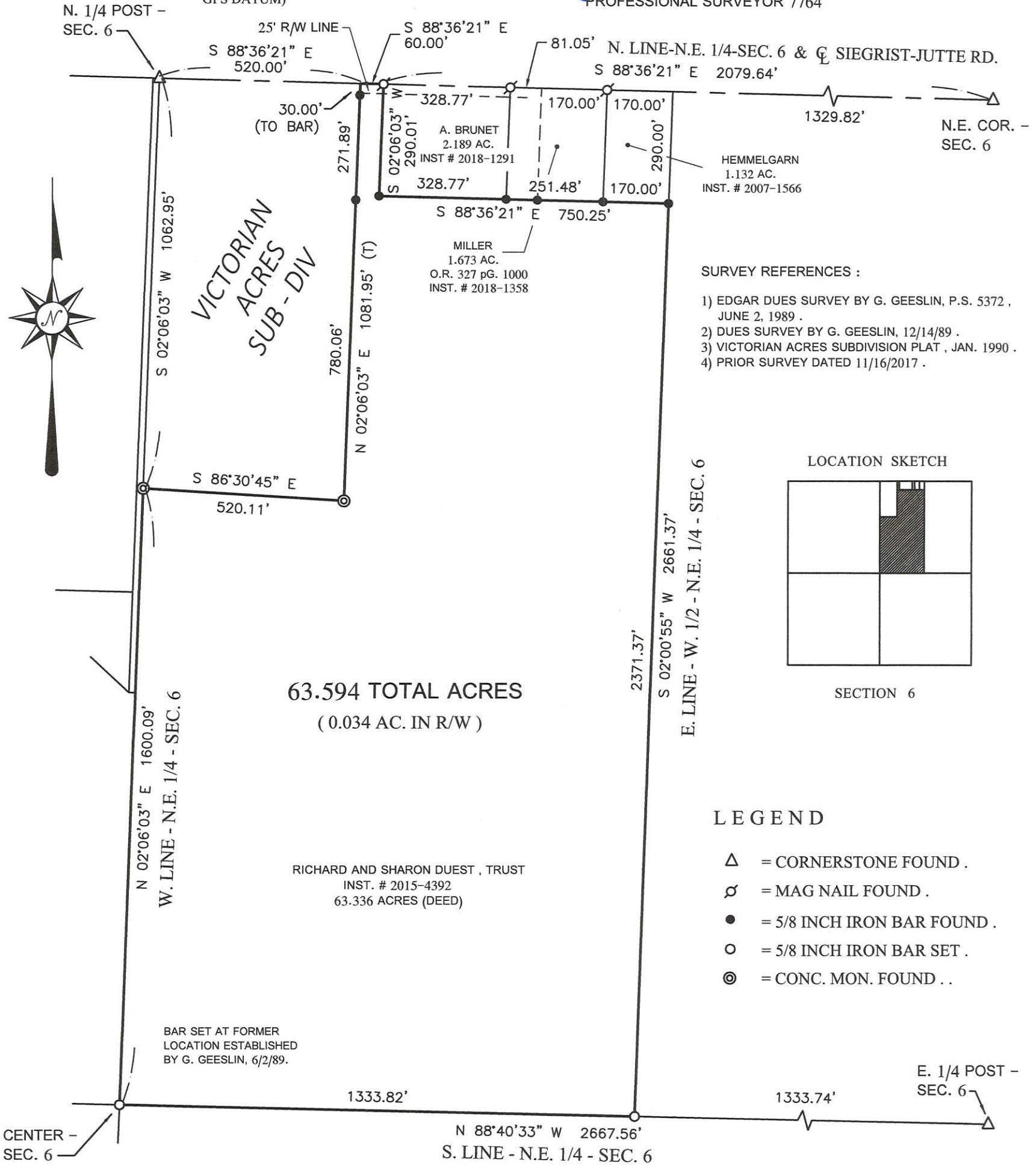

SURVEY REFERENCES :

- 1) EDGAR DUES SURVEY BY G. GEESLIN, P.S. 5372 , JUNE 2, 1989 .
- 2) DUES SURVEY BY G. GEESLIN, 12/14/89 .
- 3) VICTORIAN ACRES SUBDIVISION PLAT , JAN. 1990 .
- 4) PRIOR SURVEY DATED 11/16/2017 .

LOCATION SKETCH

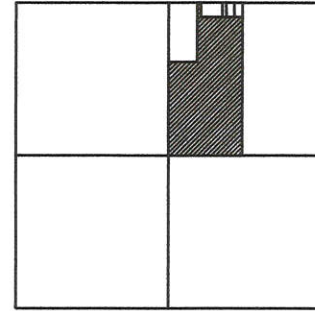

SECTION 6

LEGEND

- △ = CORNERSTONE FOUND .
- = MAG NAIL FOUND .
- = 5/8 INCH IRON BAR FOUND .
- = 5/8 INCH IRON BAR SET .
- ⊙ = CONC. MON. FOUND . .

63.594 TOTAL ACRES
(0.034 AC. IN R/W)

RICHARD AND SHARON DUEST , TRUST
INST. # 2015-4392
63.336 ACRES (DEED)

BAR SET AT FORMER
LOCATION ESTABLISHED
BY G. GEESLIN, 6/2/89.

DUES SURVEY

PART OF THE W. 1/2 OF THE N.E. 1/4 OF SEC. 6 , TOWN 7 SOUTH , RANGE 2 EAST , (BUTLER TOWNSHIP) , MERCER COUNTY , OHIO .

DECEMBER 11 , 2018



SCALE 1" = 300'

GEESLIN
LAND SURVEYING

525 S. SECOND ST.
COLDWATER, OHIO 45828

PHONE: (419)678-7233
geeslinsurveying@gmail.com

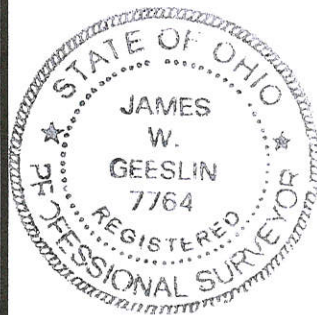

PERMANENT PARCEL No. _____

Part of: _____ Sec. ____ T. ____ R. _____ Township

Grantor: _____ Area Retained: _____ Acres

Grantee: _____ Area Retained: _____ Acres

Deed References: _____

APPROVALS:

AGENCY: _____ Board of Health _____ Township Zoning Officer _____ Mercer County Engineer

DATE: _____

SURVEY OF A 1.122 AC. TRACT FOR ROGER SIEFRING
 LOCATED IN THE FRACT. S.W. 1/4 OF SEC. 06, T-7-S,
 R-2-E; BUTLER TWP., MERCER COUNTY, STATE OF OHIO

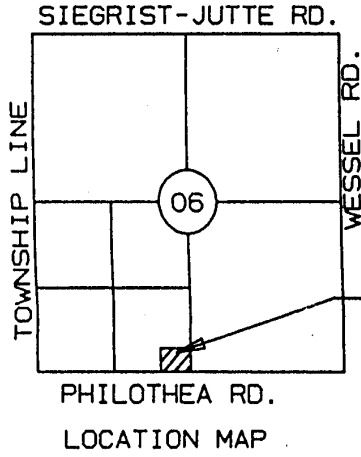

CENTER OF SEC. 06
 IRON PIN FOUND

ROGER & ROSE SIEFRING
 Vol. 207, Pg. 346

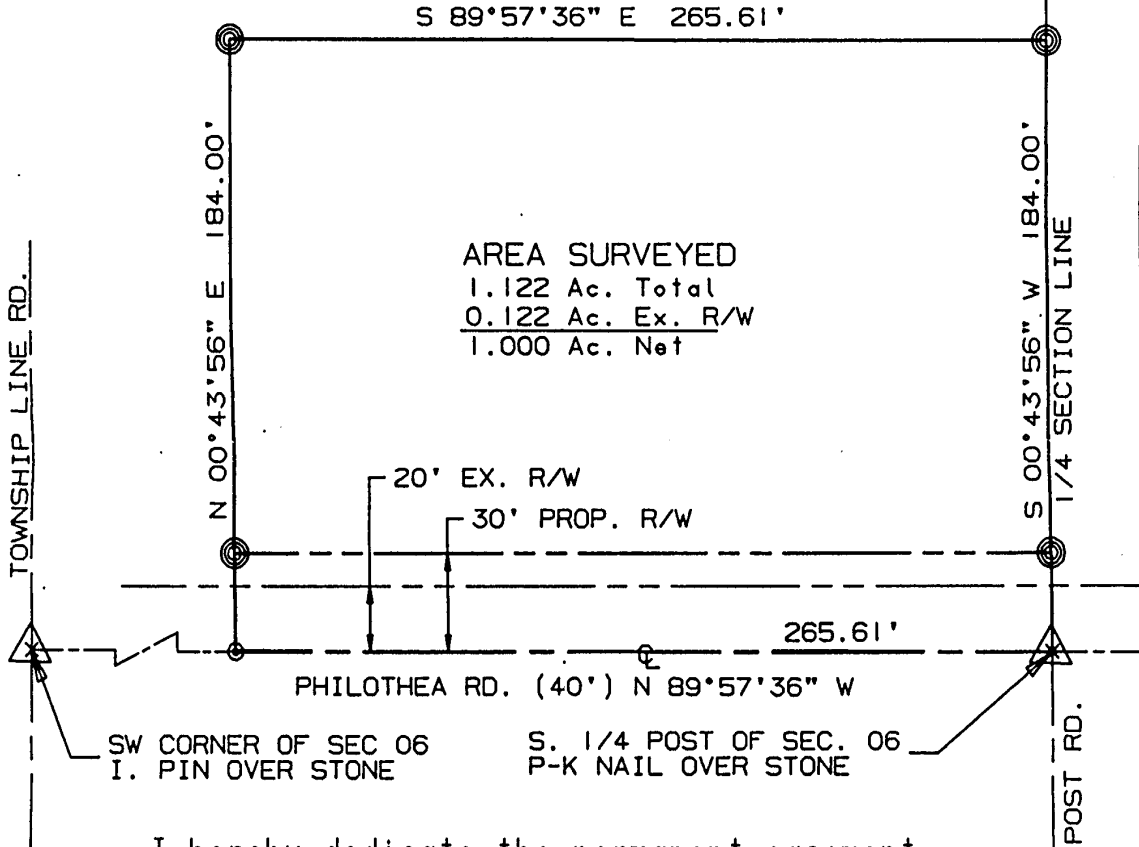

AREA SURVEYED
 1.122 Ac. Total
 0.122 Ac. Ex. R/W
 1.000 Ac. Net

I hereby dedicate the permanent easement
 for roadway purposes as shown on this plat.

Roger F. Siefring
 ROGER F. SIEFRING

Rose Ann Siefring
 ROSE ANN SIEFRING

OCT 21 1996

SURVEYED BY: *Eric C. Thomas*
 ERIC C THOMAS REG. SURVEYOR #7236
 DATE: 09-27-96

MERCER COUNTY COMMISSIONERS
 CELINA, OHIO

⊙ = P-K NAIL SET
 ⊗ = I. PIN SET

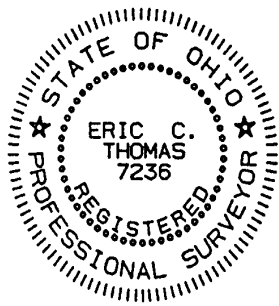

References: PREVIOUS SURVEY A OF THIS SECTION BY GORDEN GEESLIN REG. SURVEYOR #5372 DATED 6-14-88	Scale 1"=50' 0 25 50 100
Part of S.W. 1/4 Sec. 06 T7-S R2-E BUTLER Twp., MERCER Co., OHIO	
GRANTOR: R. SIEFRING DEEDS: Vol. 207 Pg. 346 AREA RETAINED ____ Ac.	
GRANTEE: _____ AREA: _____ Ac.	
APPROVALS: <i>Chad Wilhoit</i>	<i>John F. Edinger</i>
AGENCY: BO. OF HEALTH Co. San. Eng. Co. Engineer	PERMANENT PARCEL No.
DATE: 2/26/96	10-18-96