

WAYNE TWP-CELINA CORP / CELINA SD

06-29-478-003

Property Class: 510

Neighborhood

46502730-04 -

Map: 05

Block:

Card: 51

Bk: Pg:

46-026956.3000

**MAAS KATHRYN LAMMERS-**  
 MAAS KATHRYN LAMMERS-  
 2305 EAGLEBROOKE CIR  
 CELINA, OH 45822

**LEGAL INFORMATION**  
 EAGLEBROOKE ESTATES  
 SEC V PHASE I  
 LOT#: 134

Created in 2004 From 46-026956.2000 due to Split

	OWNERSHIP	ADDRESS	CITY	STATE	ZIP	DATE	AMOUNT	DEED:CONV#	JS	VALID
1	MAAS KATHRYN LAMMERS-	2305 EAGLEBROOKE CIR	CELINA	OH	45822	03/10/2023	371,500	WDC : 125	<input type="checkbox"/>	<input checked="" type="checkbox"/>
2	MARTIN JORDAN M & DONATI	2305 EAGLEBROOKE CIR	CELINA	OH	45822	05/07/2021	260,000	WDC : 359	<input type="checkbox"/>	<input checked="" type="checkbox"/>
3	CMKAB PROPERTIES LLC	6937 SILVER LAKES DR	CELINA	OH	45822	05/16/2019	39,000	WDC : 316	<input type="checkbox"/>	<input checked="" type="checkbox"/>

X:  TTO LISTER: HK DATE: 05/04/2021 TIME: 12:00:00 AM  LETTER  LETTER REC'D GIS CODE

STREET/ROAD	TOPOGRAPHY	PU-UTILITIES-PR	NEIGHBORHOOD	INFLUENCE FACTORS		PROPERTY LOCATION
<input checked="" type="checkbox"/> PAVED	<input checked="" type="checkbox"/> LEVEL	<input type="checkbox"/> WATER	<input type="checkbox"/> IMPROVING	<input type="checkbox"/> A. NO ROAD	<input type="checkbox"/> F. RESTRICT	2305 EAGLEBROOKE CIR
<input type="checkbox"/> GRAVEL	<input type="checkbox"/> HIGH	<input type="checkbox"/> SEWER	<input type="checkbox"/> STATIC	<input type="checkbox"/> B. TOPGRHY	<input type="checkbox"/> G. WOOD LT	COMMENT
<input type="checkbox"/> DIRT	<input type="checkbox"/> LOW	<input type="checkbox"/> GAS	<input type="checkbox"/> DECLINING	<input type="checkbox"/> C. Ex Front	<input type="checkbox"/> H. VACANCY	TY2022:Net Gen=\$3,990.78, Other
<input type="checkbox"/> SIDEWALKS	<input type="checkbox"/> ROLLING	<input type="checkbox"/> ELECTRIC	<input type="checkbox"/> OLD	<input type="checkbox"/> D. QUANTITY	<input type="checkbox"/> I. WATER FRONT	Assessment=\$0.00
<input type="checkbox"/> CURBS	<input type="checkbox"/> STANDARD	<input type="checkbox"/> STANDARD	<input type="checkbox"/> STANDARD	<input type="checkbox"/> E. SZ/SHAPE	<input type="checkbox"/> J. OTHER/CDU	DE21 ADD NEW DWLG

LAND COMPUTATIONS						
LAND TYPE	SIZE	M	RATE	C	INF	M VALUE C
F:Front	F118 D175	ST505	DP108	ADJ545		64,300 0
TOTAL						64,300 0

VALUATION SUMMARY						
VALUE YEAR	2023	2021	2021	2020	2017	
REASON FOR CHANGE	RAPP	RCLS	NC	RAPP	RAPP	
APPRAISED	LAND	64,300	52,200	52,200	37,200	35,400
VALUE	IMPR	238,200	197,200	197,200	0	0
	TOTAL	302,500	249,400	249,400	37,200	35,400
ASSESSED	LAND	22,510	18,270	18,270	13,020	12,390
VALUE	IMPR	83,370	69,020	69,020	0	0
	TOTAL	105,880	87,290	87,290	13,020	12,390

**OCCUPANCY**  
 SF  DU  TR  
 CONVERSION  
**BUILDING TYPE**  
 MOBILE HOME  
 BI/TR LEVEL  
 MOD/MAN

FLOOR	AREA	CONST	VALUE
1	1744	FR	219,290
BSMT	1744		24,940
<b>SUBTOTAL</b>			244,230

**ROOFING**  
 METAL  
 SLT/TLE  
 SHINGLES  
 SHAKES  
 COMPOSITE

**EXTERIOR**  
 WOOD  
 STUCCO  
 ALM/VYNL  
 CONC BLK  
 METAL  
 BRICK  
 STONE

ROOF TYPE	VALUE
<input type="checkbox"/> GABLE	
<input checked="" type="checkbox"/> HIP	
<input type="checkbox"/> GAMBREL	
<input type="checkbox"/> MANSARD	
<input type="checkbox"/> FLAT	

**FLOORS** B 1 2 3 U  
 CONCRETE       
 WOOD       
 TILE/COMPO       
 CARPET

MULTI-FAMILY #	0	0
BUILDING TYPE	100%	0
BSMT FINISH	0 S.F.	0
FIREPLACE #	0	0
HEATING	0 S.F.	0
AIR COND	1,744 S.F.	2,880
PLUMBING #	6	7,260
GARAGES & CARPORTS		14,200
EXTRA FEATURES		3,800
<b>SUBTOTAL</b>		272,370

**INT. FINISH** B 1 2 3 U  
 PLASTER/DW       
 PANELING       
 UNFINISHED

GRADE FACTOR		105 %
<b>UNADJUSTED VALUE</b>		285,990
<b>FACTOR</b>		100 %

**ACCOMMODATIONS**  
 # OF ROOMS 6  
 BEDROOMS 3  
 FIREPLACES

<b>SUBTOTAL</b>		272,370
GRADE FACTOR		105 %
<b>UNADJUSTED VALUE</b>		285,990
<b>FACTOR</b>		100 %

**HEAT & AC** B 1 2 3 U  
 NO HEAT       
 CTRL HEAT       
 HW/STEAM       
 ELECTRIC       
 HEAT PUMP       
 FLR/WALL       
 STVE/SPCE       
 GEOTHERMAL       
 OUTSIDE       
 CTRL A/C

OCCUPANCY	ST.HT	SIZE	AREA	GRADE	PRICE	AGE	REMD	CND	UNADJ VAL	PHYS	PHYS VAL	FUNC	TRUE VAL
DWELLING	1	SK	1,744	C+		2020		G	285,990	2	280,270		238,200
1													
2													
3													
4													
5													
6													
7													
8													
9													
10													
11													

**PLUMBING** BASE   
 X FULL BATH 1  
 X HALF BATH 1  
 X FIXTURES 1

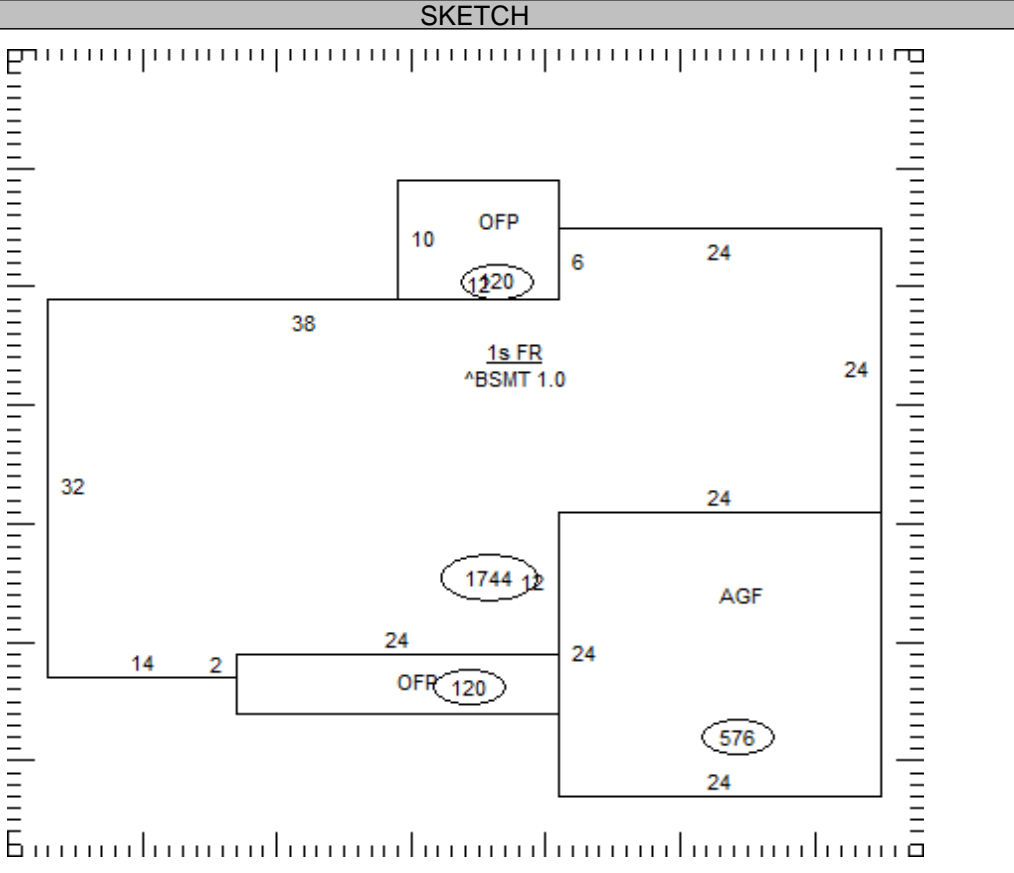

46-026956.3000

TOTAL 238,200

**COMMENTS**

Dwelling has an Economic Factor of 85%

46-026956.3000

**MAAS KATHRYN LAMMERS-**  
 MAAS KATHRYN LAMMERS-  
 2305 EAGLEBROOKE CIR  
 CELINA, OH 45822

**LEGAL INFORMATION**  
 EAGLEBROOKE ESTATES  
 SEC V PHASE I  
 LOT#: 134

Created in 2004 From 46-026956.2000 due to Split

OWNERSHIP	ADDRESS	CITY	STATE	ZIP	DATE	AMOUNT	DEED:CONV#	JS	VALID
1	INVESTACORR INC	6781 HELLWARTH RD	CELINA	OH	45822	10/06/2011	0 QCE : X : 0	<input type="checkbox"/>	<input type="checkbox"/>
2	WHITE TREE INVESTMENTS	PO BOX 317	CELINA	OH	45822	02/02/2004	0 : 0	<input type="checkbox"/>	<input type="checkbox"/>
3							0 0	<input type="checkbox"/>	<input type="checkbox"/>

X:  TTO LISTER: HK DATE: 05/04/2021 TIME: 12:00:00 AM  LETTER  LETTER REC'D GIS CODE

STREET/ROAD	TOPOGRAPHY	PU-UTILITIES-PR	NEIGHBORHOOD	INFLUENCE FACTORS	PROPERTY LOCATION
<input checked="" type="checkbox"/> PAVED	<input checked="" type="checkbox"/> LEVEL	<input type="checkbox"/> WATER <input type="checkbox"/>	<input type="checkbox"/> IMPROVING	<input type="checkbox"/> A. NO ROAD <input type="checkbox"/> F. RESTRICT	2305 EAGLEBROOKE CIR
<input type="checkbox"/> GRAVEL	<input type="checkbox"/> HIGH	<input type="checkbox"/> SEWER <input type="checkbox"/>	<input type="checkbox"/> STATIC	<input type="checkbox"/> B. TOPGRHY <input type="checkbox"/> G. WOOD LT	COMMENT
<input type="checkbox"/> DIRT	<input type="checkbox"/> LOW	<input type="checkbox"/> GAS <input type="checkbox"/>	<input type="checkbox"/> DECLINING	<input type="checkbox"/> C. Ex Front <input type="checkbox"/> H. VACANCY	
<input type="checkbox"/> SIDEWALKS	<input type="checkbox"/> ROLLING	<input type="checkbox"/> ELECTRIC <input type="checkbox"/>	<input type="checkbox"/> OLD	<input type="checkbox"/> D. QUANTITY <input type="checkbox"/> I. WATER FRONT	
<input type="checkbox"/> CURBS	<input type="checkbox"/> STANDARD	<input type="checkbox"/> STANDARD <input type="checkbox"/>	<input type="checkbox"/> STANDARD	<input type="checkbox"/> E. SZ/SHAPE <input type="checkbox"/> J. OTHER/CDU	

LAND COMPUTATIONS							
LAND TYPE	SIZE	M	RATE	C	INF	M	VALUE C
TOTAL							64,300 0

**VALUATION SUMMARY**

VALUE YEAR	REASON FOR CHANGE	APPRaised	LAND	IMPR	TOTAL	ASSESSED	LAND	IMPR	TOTAL

OCCUPANCY	EXTERIOR	FLOOR	AREA	CONST	VALUE	
<input type="checkbox"/> SF <input type="checkbox"/> DU <input type="checkbox"/> TR	<input type="checkbox"/> WOOD					
<input type="checkbox"/> CONVERSION	<input type="checkbox"/> STUCCO					
<b>BUILDING TYPE</b>	<input type="checkbox"/> ALM/VYNL					
<input type="checkbox"/> MOBILE HOME	<input type="checkbox"/> CONC BLK					
<input type="checkbox"/> BI/TR LEVEL	<input type="checkbox"/> METAL					
<input type="checkbox"/> MOD/MAN	<input type="checkbox"/> BRICK					
<input type="checkbox"/>	<input type="checkbox"/> STONE					
ROOFING	ROOF TYPE					
<input type="checkbox"/> METAL	<input type="checkbox"/> GABLE					
<input type="checkbox"/> SLT/TLE	<input type="checkbox"/> HIP					
<input type="checkbox"/> SHINGLES	<input type="checkbox"/> GAMBREL					
<input type="checkbox"/> SHAKES	<input type="checkbox"/> MANSARD					
<input type="checkbox"/> COMPOSITE	<input type="checkbox"/> FLAT					
FLOORS	B	1	2	3	U	
CONCRETE	<input type="checkbox"/>	<input type="checkbox"/>	<input type="checkbox"/>	<input type="checkbox"/>	<input type="checkbox"/>	
WOOD	<input type="checkbox"/>	<input type="checkbox"/>	<input type="checkbox"/>	<input type="checkbox"/>	<input type="checkbox"/>	
TILE/COMPO	<input type="checkbox"/>	<input type="checkbox"/>	<input type="checkbox"/>	<input type="checkbox"/>	<input type="checkbox"/>	
CARPET	<input type="checkbox"/>	<input type="checkbox"/>	<input type="checkbox"/>	<input type="checkbox"/>	<input type="checkbox"/>	
INT. FINISH	B	1	2	3	U	
PLASTER/DW	<input type="checkbox"/>	<input type="checkbox"/>	<input type="checkbox"/>	<input type="checkbox"/>	<input type="checkbox"/>	
PANELING	<input type="checkbox"/>	<input type="checkbox"/>	<input type="checkbox"/>	<input type="checkbox"/>	<input type="checkbox"/>	
UNFINISHED	<input type="checkbox"/>	<input type="checkbox"/>	<input type="checkbox"/>	<input type="checkbox"/>	<input type="checkbox"/>	
ACCOMMODATIONS						
# OF ROOMS						
BEDROOMS						
FIREPLACES						
HEAT & AC	B	1	2	3	U	
NO HEAT	<input type="checkbox"/>	<input type="checkbox"/>	<input type="checkbox"/>	<input type="checkbox"/>	<input type="checkbox"/>	
CTRL HEAT	<input type="checkbox"/>	<input type="checkbox"/>	<input type="checkbox"/>	<input type="checkbox"/>	<input type="checkbox"/>	
HW/STEAM	<input type="checkbox"/>	<input type="checkbox"/>	<input type="checkbox"/>	<input type="checkbox"/>	<input type="checkbox"/>	
ELECTRIC	<input type="checkbox"/>	<input type="checkbox"/>	<input type="checkbox"/>	<input type="checkbox"/>	<input type="checkbox"/>	
HEAT PUMP	<input type="checkbox"/>	<input type="checkbox"/>	<input type="checkbox"/>	<input type="checkbox"/>	<input type="checkbox"/>	
FLR/WALL	<input type="checkbox"/>	<input type="checkbox"/>	<input type="checkbox"/>	<input type="checkbox"/>	<input type="checkbox"/>	
STVE/SPCE	<input type="checkbox"/>	<input type="checkbox"/>	<input type="checkbox"/>	<input type="checkbox"/>	<input type="checkbox"/>	
GEO THERMAL	<input type="checkbox"/>	<input type="checkbox"/>	<input type="checkbox"/>	<input type="checkbox"/>	<input type="checkbox"/>	
OUTSIDE	<input type="checkbox"/>	<input type="checkbox"/>	<input type="checkbox"/>	<input type="checkbox"/>	<input type="checkbox"/>	
CTRL A/C	<input type="checkbox"/>	<input type="checkbox"/>	<input type="checkbox"/>	<input type="checkbox"/>	<input type="checkbox"/>	
PLUMBING		BASE <input type="checkbox"/>				
X FULL BATH						
X HALF BATH						
X FIXTURES						
SUBTOTAL						0
MULTI-FAMILY #	0					0
BUILDING TYPE	000%					0
BSMT FINISH	0 S.F.					0
FIREPLACE #	0					0
HEATING	0 S.F.					0
AIR COND	0 S.F.					0
PLUMBING #	0					0
GARAGES & CARPORTS						0
EXTRA FEATURES						0
SUBTOTAL						0
GRADE FACTOR						%
UNADJUSTED VALUE						0
FACTOR						%

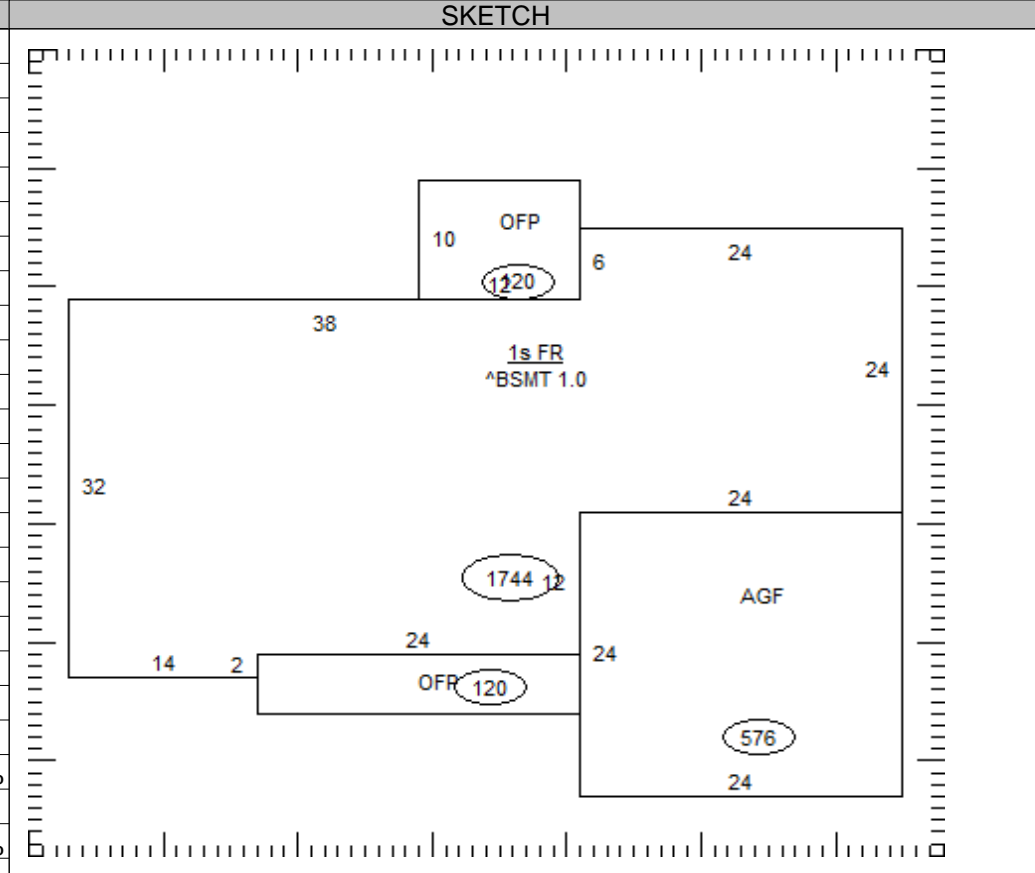

OCCUPANCY	ST.HT	SIZE	AREA	GRADE	PRICE	AGE	REMD	CND	UNADJ VAL	PHYS	PHYS VAL	FUNC	TRUE VAL
DWELLING		SK											
1													
2													
3													
4													
5													
6													
7													
8													
9													
10													
11													

46-026956.3000

TOTAL 0

COMMENTS