

43-019900.0000

HOMAN ERIC A & LARISSA M

HOMAN ERIC A & LARISSA M

4479 TOWNSHIP LINE RD

COLDWATER, OH 45828

LEGAL INFORMATION

NE COR NE

RTS: 001-06-36

Acres:1.3000

	OWNERSHIP	ADDRESS	CITY	STATE	ZIP	DATE	AMOUNT	DEED:CONV#	JS	VALID
1	HOMAN ERIC A & LARISSA M	4479 TOWNSHIP LINE RD	COLDWATER	OH	45828	03/26/2021	255,000	WDC : 216	<input type="checkbox"/>	<input checked="" type="checkbox"/>
2	SCHNEIDER JOSEPH L &	4479 TOWNSHIP LINE RD	COLDWATER	OH	45828	07/19/1988	71,000	: A : 0	<input type="checkbox"/>	<input checked="" type="checkbox"/>
3							0	0	<input type="checkbox"/>	<input type="checkbox"/>

X: TTO LISTER: HK DATE: 03/21/2022 TIME: 12:00:00 AM LETTER LETTER REC'D GIS CODE

STREET/ROAD	TOPOGRAPHY	PU-UTILITIES-PR	NEIGHBORHOOD	INFLUENCE FACTORS	PROPERTY LOCATION					
<input checked="" type="checkbox"/> PAVED	<input checked="" type="checkbox"/> LEVEL	<input type="checkbox"/> WATER	<input type="checkbox"/> IMPROVING	<input type="checkbox"/> A. NO ROAD	4479 TOWNSHIP LINE RD, COLDWATER					
<input type="checkbox"/> GRAVEL	<input type="checkbox"/> HIGH	<input type="checkbox"/> SEWER	<input checked="" type="checkbox"/> STATIC	<input type="checkbox"/> B. TOPGRHY	COMMENT					
<input type="checkbox"/> DIRT	<input type="checkbox"/> LOW	<input type="checkbox"/> GAS	<input type="checkbox"/> DECLINING	<input type="checkbox"/> C. Ex Front	TY2022:Net Gen=\$1,441.32, Other					
<input type="checkbox"/> SIDEWALKS	<input type="checkbox"/> ROLLING	<input type="checkbox"/> ELECTRIC	<input type="checkbox"/> OLD	<input type="checkbox"/> D. QUANTITY	Assessment=\$2.64					
<input type="checkbox"/> CURBS	<input type="checkbox"/> STANDARD	<input checked="" type="checkbox"/> STANDARD	<input type="checkbox"/> STANDARD	<input type="checkbox"/> E. SZ/SHAPE	DE15 COR BSMNT AREA, ADD 50 SQ FT					
LAND COMPUTATIONS					AREA/PER DATA MAILER					
LAND TYPE	SIZE	M	RATE	C	INF	M	VALUE	C		
HS:Home Site	AC:1	28470				28,500	0			
SM:Small Acreage	AC:0.3	8500				2,600	0			
Total Acres: 1.3000					TOTAL	31,100	0			

4479 TOWNSHIP LINE RD, COLDWATER
 COMMENT
 TY2022:Net Gen=\$1,441.32, Other
 Assessment=\$2.64
 DE15 COR BSMNT AREA, ADD 50 SQ FT
 AREA/PER DATA MAILER
 DE17 DESKTOP RVW CHG: COR SK, ADD PAT &
 2 SHEDS
 DE22 RMV DET GAR & SHED
 DE22 RMV HOMESTEAD CREDIT
 NC24 CHK FOR NC

VALUATION SUMMARY

VALUE YEAR	2023	2022	2020	2017	2017			
REASON FOR CHANGE	RAPP	REMB	RAPP	RAPP	MISC			
APPRAISED	LAND	31,100	20,500	20,500	18,600	18,500		
VALUE	IMPR	111,600	92,000	95,400	81,200	72,900		
	TOTAL	142,700	112,500	115,900	99,800	91,400		
ASSESSED	LAND	10,890	7,180	7,180	6,510	6,480		
VALUE	IMPR	39,060	32,200	33,390	28,420	25,520		
	TOTAL	49,950	39,380	40,570	34,930	32,000		

OCCUPANCY	EXTERIOR	FLOOR	AREA	CONST	VALUE	
<input checked="" type="checkbox"/> SF <input type="checkbox"/> DU <input type="checkbox"/> TR	<input checked="" type="checkbox"/> WOOD	1	1218	FR	180,320	
<input type="checkbox"/> CONVERSION	<input type="checkbox"/> STUCCO	.25	224	FR	30,250	
BUILDING TYPE						
<input type="checkbox"/> MOBILE HOME	<input checked="" type="checkbox"/> ALM/VYNL					
<input type="checkbox"/> BI/TR LEVEL	<input type="checkbox"/> CONC BLK					
<input type="checkbox"/> MOD/MAN	<input type="checkbox"/> METAL					
<input type="checkbox"/>	<input type="checkbox"/> BRICK					
	<input type="checkbox"/> STONE					
ROOFING						
ROOF TYPE						
<input type="checkbox"/> METAL	<input checked="" type="checkbox"/> GABLE					
<input type="checkbox"/> SLT/TLE	<input type="checkbox"/> HIP					
<input checked="" type="checkbox"/> SHINGLES	<input type="checkbox"/> GAMBREL					
<input type="checkbox"/> SHAKES	<input type="checkbox"/> MANSARD					
<input type="checkbox"/> COMPOSITE	<input type="checkbox"/> FLAT					
FLOORS		B	1	2	3	U
CONCRETE	<input checked="" type="checkbox"/>	<input type="checkbox"/>	<input type="checkbox"/>	<input type="checkbox"/>	<input type="checkbox"/>	<input type="checkbox"/>
WOOD	<input type="checkbox"/>	<input checked="" type="checkbox"/>	<input checked="" type="checkbox"/>	<input type="checkbox"/>	<input type="checkbox"/>	<input type="checkbox"/>
TILE/COMPO	<input type="checkbox"/>	<input type="checkbox"/>	<input type="checkbox"/>	<input type="checkbox"/>	<input type="checkbox"/>	<input type="checkbox"/>
CARPET	<input type="checkbox"/>	<input type="checkbox"/>	<input type="checkbox"/>	<input type="checkbox"/>	<input type="checkbox"/>	<input type="checkbox"/>
INT. FINISH		B	1	2	3	U
PLASTER/DW	<input type="checkbox"/>	<input type="checkbox"/>	<input checked="" type="checkbox"/>	<input type="checkbox"/>	<input type="checkbox"/>	<input type="checkbox"/>
PANELING	<input type="checkbox"/>	<input checked="" type="checkbox"/>	<input type="checkbox"/>	<input type="checkbox"/>	<input type="checkbox"/>	<input type="checkbox"/>
UNFINISHED	<input checked="" type="checkbox"/>	<input type="checkbox"/>	<input type="checkbox"/>	<input type="checkbox"/>	<input type="checkbox"/>	<input type="checkbox"/>
ACCOMMODATIONS						
# OF ROOMS		4	1			
BEDROOMS		2	1			
FIREPLACES						
HEAT & AC		B	1	2	3	U
NO HEAT	<input type="checkbox"/>	<input type="checkbox"/>	<input type="checkbox"/>	<input type="checkbox"/>	<input type="checkbox"/>	<input type="checkbox"/>
CTRL HEAT	<input type="checkbox"/>	<input checked="" type="checkbox"/>	<input checked="" type="checkbox"/>	<input type="checkbox"/>	<input type="checkbox"/>	<input type="checkbox"/>
HW/STEAM	<input type="checkbox"/>	<input type="checkbox"/>	<input type="checkbox"/>	<input type="checkbox"/>	<input type="checkbox"/>	<input type="checkbox"/>
ELECTRIC	<input type="checkbox"/>	<input type="checkbox"/>	<input type="checkbox"/>	<input type="checkbox"/>	<input type="checkbox"/>	<input type="checkbox"/>
HEAT PUMP	<input type="checkbox"/>	<input type="checkbox"/>	<input type="checkbox"/>	<input type="checkbox"/>	<input type="checkbox"/>	<input type="checkbox"/>
FLR/WALL	<input type="checkbox"/>	<input type="checkbox"/>	<input type="checkbox"/>	<input type="checkbox"/>	<input type="checkbox"/>	<input type="checkbox"/>
STVE/SPCE	<input type="checkbox"/>	<input type="checkbox"/>	<input type="checkbox"/>	<input type="checkbox"/>	<input type="checkbox"/>	<input type="checkbox"/>
GEOTHERMAL	<input type="checkbox"/>	<input type="checkbox"/>	<input type="checkbox"/>	<input type="checkbox"/>	<input type="checkbox"/>	<input type="checkbox"/>
OUTSIDE	<input type="checkbox"/>	<input type="checkbox"/>	<input type="checkbox"/>	<input type="checkbox"/>	<input type="checkbox"/>	<input type="checkbox"/>
CTRL A/C	<input type="checkbox"/>	<input checked="" type="checkbox"/>	<input checked="" type="checkbox"/>	<input type="checkbox"/>	<input type="checkbox"/>	<input type="checkbox"/>
PLUMBING			BASE <input checked="" type="checkbox"/>			
X FULL BATH						
X HALF BATH						
X FIXTURES						
BSMT			968		13,840	
SUBTOTAL					224,410	
MULTI-FAMILY #		0			0	
BUILDING TYPE		100%			0	
BSMT FINISH		0 S.F.			0	
FIREPLACE #		0			0	
HEATING		0 S.F.			0	
AIR COND		1,442 S.F.			2,380	
PLUMBING #		0			0	
GARAGES & CARPORTS					0	
EXTRA FEATURES					2,800	
SUBTOTAL					229,590	
GRADE FACTOR					100 %	
UNADJUSTED VALUE					229,590	
FACTOR					100 %	

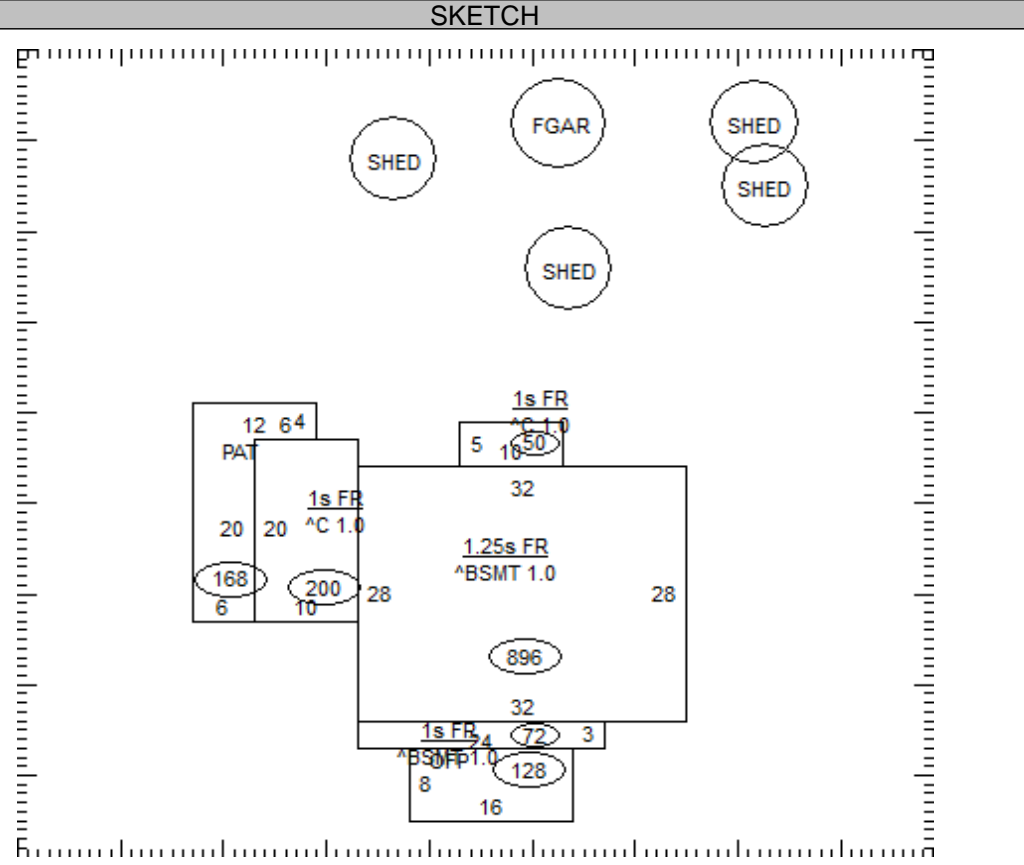

OCCUPANCY	ST.HT	SIZE	AREA	GRADE	PRICE	AGE	REMD	CND	UNADJ VAL	PHYS	PHYS VAL	FUNC	TRUE VAL
DWELLING	1.25	SK	1,442	C		1945		A	229,590	45	126,270		107,300
1 Gar - Frame		0x0	1,310	C	23.70	1940		A	31,050	95	1,550		1,600
2 Shed	10	45x60	2,700	C	10.48	1950		A	28,300	95	1,420		1,400
3 Shed	10	22x42	924	D	5.28	1920		A	4,880	95	240		200
4 Shed		10x14	140	C		2000		A		37			0
5 Shed		12x14	168	C	9.90	2000		A	1,660	37	1,050		1,100
6													
7													
8													
9													
10													
11													

43-019900.0000

TOTAL 111,600

COMMENTS

VINYL SIDING
 >>OB Features: 1.2 <Add Concrete Floor>
 Dwelling has an Economic Factor of 85% (Rollback Basis=\$137,400)