



43-002100.0200

**MUHLENKAMP SETH D & KELLY M**

MUHLENKAMP SETH D & KELLY M

16 SCHROEDER RD

FORT RECOVERY, OH 45846

**LEGAL INFORMATION**

NE CORNER PT N 1/2 NW

RTS: 001-06-07

Acres:2.0000

	OWNERSHIP	ADDRESS	CITY	STATE	ZIP	DATE	AMOUNT	DEED:CONV#	JS	VALID
1	MUHLENKAMP SETH D &	16 SCHROEDER RD	FORT RECOVERY	OH	45846	07/03/2023	435,000	WDC : 380	<input type="checkbox"/>	<input type="checkbox"/>
2	MUHLENKAMP JOEL A	117 STATE ROUTE 219	FORT RECOVERY	OH	45846	10/12/2021	495,000	WDC : 877	<input type="checkbox"/>	<input checked="" type="checkbox"/>
3	COOPER COLE V & VANESSA	16 SCHROEDER RD	FORT RECOVERY	OH	45846	01/14/2011	265,000	WDC : A : 26	<input type="checkbox"/>	<input checked="" type="checkbox"/>

X:  TTO LISTER: BTC DATE: 07/21/2009 TIME: 12:00:00 AM  LETTER  LETTER REC'D GIS CODE Minor Sub

STREET/ROAD	TOPOGRAPHY	PU-UTILITIES-PR	NEIGHBORHOOD	INFLUENCE FACTORS	PROPERTY LOCATION
<input checked="" type="checkbox"/> PAVED	<input checked="" type="checkbox"/> LEVEL	<input type="checkbox"/> WATER	<input checked="" type="checkbox"/> IMPROVING	<input type="checkbox"/> A. NO ROAD	16 SCHROEDER RD, FT RECOVERY
<input type="checkbox"/> GRAVEL	<input type="checkbox"/> HIGH	<input type="checkbox"/> SEWER	<input checked="" type="checkbox"/> STATIC	<input type="checkbox"/> B. TOPGRHY	COMMENT
<input type="checkbox"/> DIRT	<input type="checkbox"/> LOW	<input type="checkbox"/> GAS	<input type="checkbox"/> DECLINING	<input type="checkbox"/> C. Ex Front	TY2022:Net Gen=\$3,735.80, Other
<input type="checkbox"/> SIDEWALKS	<input type="checkbox"/> ROLLING	<input checked="" type="checkbox"/> ELECTRIC	<input type="checkbox"/> OLD	<input type="checkbox"/> D. QUANTITY	Assessment=\$0.00
<input type="checkbox"/> CURBS	<input type="checkbox"/> STANDARD	<input type="checkbox"/> STANDARD	<input type="checkbox"/> STANDARD	<input type="checkbox"/> E. SZ/SHAPE	DE09 ADD OFF
				<input type="checkbox"/> F. RESTRICT	DE21 INGR POOL; VERIFIED ON AERIAL
				<input type="checkbox"/> G. WOOD LT	
				<input type="checkbox"/> H. VACANCY	
				<input type="checkbox"/> I. WATER FRONT	
				<input type="checkbox"/> J. OTHER/CDU	

LAND COMPUTATIONS						
LAND TYPE	SIZE	M	RATE	C	INF	M VALUE C
HS:Home Site	AC:1	28470				28,500 0
SM:Small Acreage	AC:1	8500				8,500 0
Total Acres: 2.0000					TOTAL	37,000 0

VALUATION SUMMARY						
VALUE YEAR	2023	2021	2020	2017	2017	
REASON FOR CHANGE	RAPP	NC	RAPP	RAPP	MISC	
APPRAISED <u>LAND</u>	37,000	25,900	25,900	23,500	23,800	
VALUE <u>IMPR</u>	297,400	259,100	248,800	224,000	239,500	
<u>TOTAL</u>	334,400	285,000	274,700	247,500	263,300	
ASSESSED <u>LAND</u>	12,950	9,070	9,070	8,230	8,330	
VALUE <u>IMPR</u>	104,090	90,690	87,080	78,400	83,830	
<u>TOTAL</u>	117,040	99,760	96,150	86,630	92,160	

OCCUPANCY	EXTERIOR
<input checked="" type="checkbox"/> SF <input type="checkbox"/> DU <input type="checkbox"/> TR	<input type="checkbox"/> WOOD
<input type="checkbox"/> CONVERSION	<input type="checkbox"/> STUCCO
<b>BUILDING TYPE</b>	<input type="checkbox"/> ALM/VYNL
<input type="checkbox"/> MOBILE HOME	<input type="checkbox"/> CONC BLK
<input type="checkbox"/> BI/TR LEVEL	<input type="checkbox"/> METAL
<input type="checkbox"/> MOD/MAN	<input checked="" type="checkbox"/> BRICK
<input type="checkbox"/>	<input type="checkbox"/> STONE

ROOFING	ROOF TYPE
<input type="checkbox"/> METAL	<input checked="" type="checkbox"/> GABLE
<input type="checkbox"/> SLT/TLE	<input type="checkbox"/> HIP
<input checked="" type="checkbox"/> SHINGLES	<input type="checkbox"/> GAMBREL
<input type="checkbox"/> SHAKES	<input type="checkbox"/> MANSARD
<input type="checkbox"/> COMPOSITE	<input type="checkbox"/> FLAT

FLOORS	B	1	2	3	U
CONCRETE	<input checked="" type="checkbox"/>	<input type="checkbox"/>	<input type="checkbox"/>	<input type="checkbox"/>	<input type="checkbox"/>
WOOD	<input type="checkbox"/>	<input type="checkbox"/>	<input type="checkbox"/>	<input type="checkbox"/>	<input type="checkbox"/>
TILE/COMPO	<input type="checkbox"/>	<input checked="" type="checkbox"/>	<input type="checkbox"/>	<input type="checkbox"/>	<input type="checkbox"/>
CARPET	<input type="checkbox"/>	<input checked="" type="checkbox"/>	<input type="checkbox"/>	<input type="checkbox"/>	<input type="checkbox"/>

INT. FINISH	B	1	2	3	U
PLASTER/DW	<input type="checkbox"/>	<input checked="" type="checkbox"/>	<input type="checkbox"/>	<input type="checkbox"/>	<input type="checkbox"/>
PANELING	<input type="checkbox"/>	<input type="checkbox"/>	<input type="checkbox"/>	<input type="checkbox"/>	<input type="checkbox"/>
UNFINISHED	<input checked="" type="checkbox"/>	<input type="checkbox"/>	<input type="checkbox"/>	<input type="checkbox"/>	<input type="checkbox"/>

ACCOMMODATIONS					
# OF ROOMS		5			
BEDROOMS		3			
FIREPLACES		1			

HEAT & AC	B	1	2	3	U
NO HEAT	<input type="checkbox"/>	<input type="checkbox"/>	<input type="checkbox"/>	<input type="checkbox"/>	<input type="checkbox"/>
CTRL HEAT	<input type="checkbox"/>	<input checked="" type="checkbox"/>	<input type="checkbox"/>	<input type="checkbox"/>	<input type="checkbox"/>
HW/STEAM	<input type="checkbox"/>	<input type="checkbox"/>	<input type="checkbox"/>	<input type="checkbox"/>	<input type="checkbox"/>
ELECTRIC	<input type="checkbox"/>	<input type="checkbox"/>	<input type="checkbox"/>	<input type="checkbox"/>	<input type="checkbox"/>
HEAT PUMP	<input type="checkbox"/>	<input type="checkbox"/>	<input type="checkbox"/>	<input type="checkbox"/>	<input type="checkbox"/>
FLR/WALL	<input type="checkbox"/>	<input type="checkbox"/>	<input type="checkbox"/>	<input type="checkbox"/>	<input type="checkbox"/>
STVE/SPCE	<input type="checkbox"/>	<input type="checkbox"/>	<input type="checkbox"/>	<input type="checkbox"/>	<input type="checkbox"/>
GEO THERMAL	<input type="checkbox"/>	<input type="checkbox"/>	<input type="checkbox"/>	<input type="checkbox"/>	<input type="checkbox"/>
OUTSIDE	<input type="checkbox"/>	<input type="checkbox"/>	<input type="checkbox"/>	<input type="checkbox"/>	<input type="checkbox"/>
CTRL A/C	<input type="checkbox"/>	<input checked="" type="checkbox"/>	<input type="checkbox"/>	<input type="checkbox"/>	<input type="checkbox"/>

PLUMBING	BASE	
X FULL BATH		
X HALF BATH	1	
X FIXTURES		

FLOOR	AREA	CONST	VALUE
1	2186	BRK	265,660
BSMT	2186		31,260
<b>SUBTOTAL</b>			<b>296,920</b>
MULTI-FAMILY #	0		0
BUILDING TYPE	100%		0
BSMT FINISH	0 S.F.		0
FIREPLACE #	1		4,400
HEATING	0 S.F.		0
AIR COND	2,186 S.F.		3,610
PLUMBING #	2		2,420
GARAGES & CARPORTS			30,700
EXTRA FEATURES			21,800
<b>SUBTOTAL</b>			<b>359,850</b>
GRADE FACTOR			105 %
<b>UNADJUSTED VALUE</b>			<b>377,840</b>
FACTOR			100 %

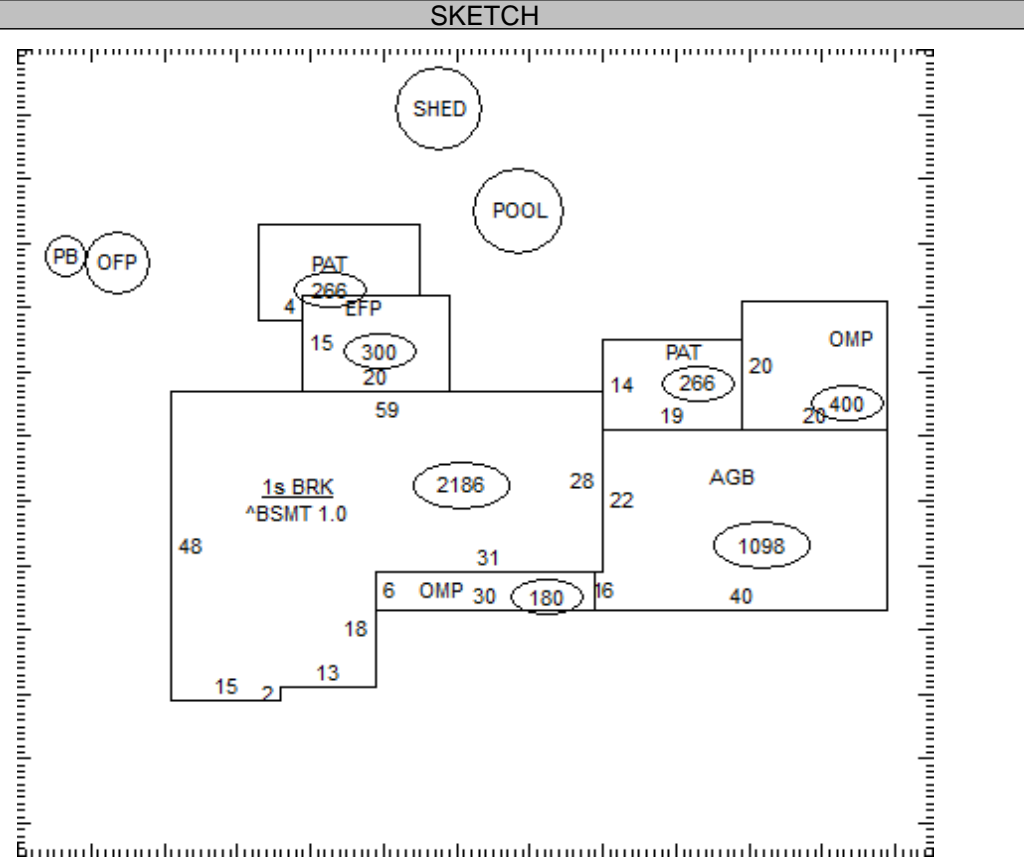

OCCUPANCY	ST.HT	SIZE	AREA	GRADE	PRICE	AGE	REMD	CND	UNADJ VAL	PHYS	PHYS VAL	FUNC	TRUE VAL
DWELLING	1	SK	2,186	C+		1993		A	377,840	24	287,160		244,100
1 OFFP		0x0	318	C	16.04	2003		A	5,100	35	3,320		3,300
2 Pole Bldg	16	40x60	2,400	B	18.30	2002		A	43,920	33	29,430		29,400
3 Shed		15x22	330	C	7.70	2009		A	2,540	23	1,960		2,000
4 Pool - Inground		16x32	512	C	37.50	2020		A	19,200	3	18,620		18,600
5													
6													
7													
8													
9													
10													
11													

43-002100.0200 TOTAL 297,400

COMMENTS

>>OB Features: 1.2 <Add Concrete Floor>  
Dwelling has an Economic Factor of 85%

43-002100.0200

**MUHLENKAMP SETH D & KELLY M**  
 MUHLENKAMP SETH D & KELLY M  
 16 SCHROEDER RD  
 FORT RECOVERY, OH 45846

**LEGAL INFORMATION**  
 NE CORNER PT N 1/2 NW

RTS: 001-06-07  
 Acres:2.0000

	OWNERSHIP	ADDRESS	CITY	STATE	ZIP	DATE	AMOUNT	DEED:CONV#	JS	VALID
1	TEBBE MATTHEW A & PAMELA	16 SCHROEDER RD	FT RECOVERY	OH	45846	04/12/1993	12,000	: A : 0	<input type="checkbox"/>	<input checked="" type="checkbox"/>
2							0	0	<input type="checkbox"/>	<input type="checkbox"/>
3							0	0	<input type="checkbox"/>	<input type="checkbox"/>

X:  TTO LISTER: BTC DATE: 07/21/2009 TIME: 12:00:00 AM  LETTER  LETTER REC'D GIS CODE Minor Sub

STREET/ROAD	TOPOGRAPHY	PU-UTILITIES-PR	NEIGHBORHOOD	INFLUENCE FACTORS	PROPERTY LOCATION	
<input checked="" type="checkbox"/> PAVED <input type="checkbox"/> GRAVEL <input type="checkbox"/> DIRT <input type="checkbox"/> SIDEWALKS <input type="checkbox"/> CURBS	<input checked="" type="checkbox"/> LEVEL <input type="checkbox"/> HIGH <input type="checkbox"/> LOW <input type="checkbox"/> ROLLING <input type="checkbox"/> STANDARD	<input type="checkbox"/> WATER <input type="checkbox"/> SEWER <input type="checkbox"/> GAS <input checked="" type="checkbox"/> ELECTRIC <input type="checkbox"/> STANDARD	<input type="checkbox"/> IMPROVING <input checked="" type="checkbox"/> STATIC <input type="checkbox"/> DECLINING <input type="checkbox"/> OLD <input type="checkbox"/> STANDARD	<input type="checkbox"/> A. NO ROAD <input type="checkbox"/> B. TOPGRHY <input type="checkbox"/> C. Ex Front <input type="checkbox"/> D. QUANTITY <input type="checkbox"/> E. SZ/SHAPE	<input type="checkbox"/> F. RESTRICT <input type="checkbox"/> G. WOOD LT <input type="checkbox"/> H. VACANCY <input type="checkbox"/> I. WATER FRONT <input type="checkbox"/> J. OTHER/CDU	16 SCHROEDER RD, FT RECOVERY COMMENT

LAND COMPUTATIONS							
LAND TYPE	SIZE	M	RATE	C	INF	M	VALUE C
Total Acres: 2.0000					TOTAL		37,000 0

**VALUATION SUMMARY**

VALUE YEAR	REASON FOR CHANGE	APPRaised	IMPR	TOTAL	ASSESSED	IMPR	TOTAL

OCCUPANCY	EXTERIOR	FLOOR	AREA	CONST	VALUE
<input type="checkbox"/> SF <input type="checkbox"/> DU <input type="checkbox"/> TR	<input type="checkbox"/> WOOD				
<input type="checkbox"/> CONVERSION	<input type="checkbox"/> STUCCO				
<b>BUILDING TYPE</b>	<input type="checkbox"/> ALM/VYNL				
<input type="checkbox"/> MOBILE HOME	<input type="checkbox"/> CONC BLK				
<input type="checkbox"/> BI/TR LEVEL	<input type="checkbox"/> METAL				
<input type="checkbox"/> MOD/MAN	<input type="checkbox"/> BRICK				
<input type="checkbox"/>	<input type="checkbox"/> STONE				
ROOFING	ROOF TYPE				
<input type="checkbox"/> METAL	<input type="checkbox"/> GABLE				
<input type="checkbox"/> SLT/TLE	<input type="checkbox"/> HIP				
<input type="checkbox"/> SHINGLES	<input type="checkbox"/> GAMBREL				
<input type="checkbox"/> SHAKES	<input type="checkbox"/> MANSARD				
<input type="checkbox"/> COMPOSITE	<input type="checkbox"/> FLAT				

SUBTOTAL			0
MULTI-FAMILY #	0		0
BUILDING TYPE	000%		0
BSMT FINISH	0 S.F.		0
FIREPLACE #	0		0
HEATING	0 S.F.		0
AIR COND	0 S.F.		0
PLUMBING #	0		0
GARAGES & CARPORTS			0
EXTRA FEATURES			0
SUBTOTAL			0
GRADE FACTOR			%
UNADJUSTED VALUE			0
FACTOR			%

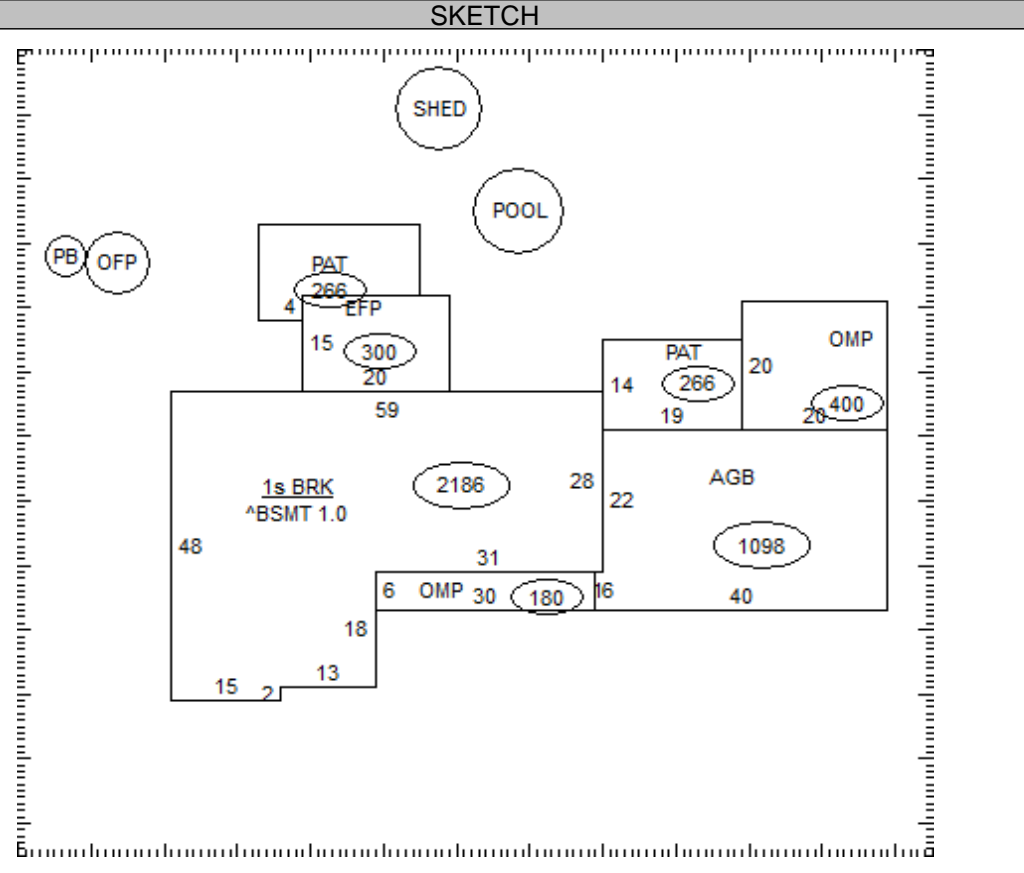

OCCUPANCY	ST.HT	SIZE	AREA	GRADE	PRICE	AGE	REMD	CND	UNADJ VAL	PHYS	PHYS VAL	FUNC	TRUE VAL
DWELLING		SK											
1													
2													
3													
4													
5													
6													
7													
8													
9													
10													
11													

43-002100.0200

TOTAL 0

COMMENTS