

WASHINGTON TWP / CELINA SD

07-02-400-004

42-002200.0000

**LEGAL INFORMATION**

OUT E1/2 SE

RTS: 001-06-02

Acres:2.7500

**LITMER JOSHUA P & MILLER ALLIE R**

LITMER JOSHUA P & MILLER ALLIE R

2492 STATE ROUTE 29

CELINA, OH 45822

	OWNERSHIP	ADDRESS	CITY	STATE	ZIP	DATE	AMOUNT	DEED:CONV#	JS	VALID
1	LITMER JOSHUA P & MILLER	2492 STATE ROUTE 29	CELINA	OH	45822	05/26/2023	0	QCE : X : 0	<input type="checkbox"/>	<input type="checkbox"/>
2	LITMER JOSHUA	2492 STATE ROUTE 29	CELINA	OH	45822	02/13/2023	160,000	WDC : 62	<input type="checkbox"/>	<input checked="" type="checkbox"/>
3	HOLLERAN NEAL E	429 JOHNSON ST	CELINA	OH	45822	10/19/2009	26,500	WDC : A : 613	<input type="checkbox"/>	<input checked="" type="checkbox"/>

X:  TTO LISTER: JL DATE: 06/07/2012 TIME: 12:00:00 AM  LETTER  LETTER REC'D GIS CODE

STREET/ROAD	TOPOGRAPHY	PU-UTILITIES-PR	NEIGHBORHOOD	INFLUENCE FACTORS	PROPERTY LOCATION	
<input checked="" type="checkbox"/> PAVED <input type="checkbox"/> GRAVEL <input type="checkbox"/> DIRT <input type="checkbox"/> SIDEWALKS <input type="checkbox"/> CURBS	<input checked="" type="checkbox"/> LEVEL <input type="checkbox"/> HIGH <input type="checkbox"/> LOW <input type="checkbox"/> ROLLING <input type="checkbox"/> STANDARD	<input type="checkbox"/> WATER <input type="checkbox"/> SEWER <input checked="" type="checkbox"/> GAS <input checked="" type="checkbox"/> ELECTRIC <input type="checkbox"/> STANDARD	<input type="checkbox"/> IMPROVING <input checked="" type="checkbox"/> STATIC <input type="checkbox"/> DECLINING <input type="checkbox"/> OLD <input type="checkbox"/> STANDARD	<input type="checkbox"/> A. NO ROAD <input type="checkbox"/> B. TOPGRHY <input type="checkbox"/> C. Ex Front <input type="checkbox"/> D. QUANTITY <input type="checkbox"/> E. SZ/SHAPE	<input type="checkbox"/> F. RESTRICT <input type="checkbox"/> G. WOOD LT <input type="checkbox"/> H. VACANCY <input type="checkbox"/> I. WATER FRONT <input type="checkbox"/> J. OTHER/CDU	2492 ST RT 29, CELINA <b>COMMENT</b> TY2022:Net Gen=\$1,680.06, Other Assessment=\$57.58 DE12 ADD PB, WDDK ON REAR OF DWLG, AC, RMMDL EXT OF DWLG, NEW WINDOWS, SIDING, MTL ROOFING DE12 RMV CDU ON DLWG DE17 DESKTOP RVW CHG: RMV LT

**LAND COMPUTATIONS**

LAND TYPE	SIZE	M	RATE	C	INF	M	VALUE	C
HS:Home Site	AC:1	22370				22,400	0	
SM:Small Acreage	AC:1.75	8300				14,500	0	
						<b>TOTAL</b>	36,900	0

**VALUATION SUMMARY**

VALUE YEAR	2023	2020	2017	2017				
REASON FOR CHANGE	RAPP	RAPP	RAPP	MISC				
APPRAISED VALUE	LAND 36,900	31,500	28,400	22,900				
	IMPR 90,200	70,700	59,800	47,600				
	TOTAL 127,100	102,200	88,200	70,500				
ASSESSED VALUE	LAND 12,920	11,030	9,940	8,020				
	IMPR 31,570	24,750	20,930	16,660				
	TOTAL 44,490	35,780	30,870	24,680				

OCCUPANCY	EXTERIOR	FLOOR	AREA	CONST	VALUE
<input checked="" type="checkbox"/> SF <input type="checkbox"/> DU <input type="checkbox"/> TR	<input type="checkbox"/> WOOD	1	760	FR	130,070
<input type="checkbox"/> CONVERSION	<input type="checkbox"/> STUCCO	.5	200	FR	21,220
<b>BUILDING TYPE</b>	<input checked="" type="checkbox"/> ALM/VYNL				
<input type="checkbox"/> MOBILE HOME	<input type="checkbox"/> CONC BLK				
<input type="checkbox"/> BI/TR LEVEL	<input type="checkbox"/> METAL				
<input type="checkbox"/> MOD/MAN	<input type="checkbox"/> BRICK				
<input type="checkbox"/>	<input type="checkbox"/> STONE				

ROOFING	ROOF TYPE
<input checked="" type="checkbox"/> METAL	<input checked="" type="checkbox"/> GABLE
<input type="checkbox"/> SLT/TLE	<input type="checkbox"/> HIP
<input type="checkbox"/> SHINGLES	<input type="checkbox"/> GAMBREL
<input type="checkbox"/> SHAKES	<input type="checkbox"/> MANSARD
<input type="checkbox"/> COMPOSITE	<input type="checkbox"/> FLAT

FLOORS	B	1	2	3	U
CONCRETE	<input type="checkbox"/>	<input type="checkbox"/>	<input type="checkbox"/>	<input type="checkbox"/>	<input type="checkbox"/>
WOOD	<input type="checkbox"/>	<input checked="" type="checkbox"/>	<input checked="" type="checkbox"/>	<input type="checkbox"/>	<input type="checkbox"/>
TILE/COMPO	<input type="checkbox"/>	<input type="checkbox"/>	<input type="checkbox"/>	<input type="checkbox"/>	<input type="checkbox"/>
CARPET	<input type="checkbox"/>	<input type="checkbox"/>	<input type="checkbox"/>	<input type="checkbox"/>	<input type="checkbox"/>
INT. FINISH	B	1	2	3	U
PLASTER/DW	<input type="checkbox"/>	<input checked="" type="checkbox"/>	<input checked="" type="checkbox"/>	<input type="checkbox"/>	<input type="checkbox"/>
PANELING	<input type="checkbox"/>	<input type="checkbox"/>	<input type="checkbox"/>	<input type="checkbox"/>	<input type="checkbox"/>
UNFINISHED	<input type="checkbox"/>	<input checked="" type="checkbox"/>	<input type="checkbox"/>	<input type="checkbox"/>	<input type="checkbox"/>
ACCOMMODATIONS					
# OF ROOMS		4	2		
BEDROOMS		1	2		
FIREPLACES					
HEAT & AC	B	1	2	3	U
NO HEAT	<input type="checkbox"/>	<input type="checkbox"/>	<input type="checkbox"/>	<input type="checkbox"/>	<input type="checkbox"/>
CTRL HEAT	<input type="checkbox"/>	<input checked="" type="checkbox"/>	<input checked="" type="checkbox"/>	<input type="checkbox"/>	<input type="checkbox"/>
HW/STEAM	<input type="checkbox"/>	<input type="checkbox"/>	<input type="checkbox"/>	<input type="checkbox"/>	<input type="checkbox"/>
ELECTRIC	<input type="checkbox"/>	<input type="checkbox"/>	<input type="checkbox"/>	<input type="checkbox"/>	<input type="checkbox"/>
HEAT PUMP	<input type="checkbox"/>	<input type="checkbox"/>	<input type="checkbox"/>	<input type="checkbox"/>	<input type="checkbox"/>
FLR/WALL	<input type="checkbox"/>	<input type="checkbox"/>	<input type="checkbox"/>	<input type="checkbox"/>	<input type="checkbox"/>
STVE/SPCE	<input type="checkbox"/>	<input type="checkbox"/>	<input type="checkbox"/>	<input type="checkbox"/>	<input type="checkbox"/>
GEOTHERMAL	<input type="checkbox"/>	<input type="checkbox"/>	<input type="checkbox"/>	<input type="checkbox"/>	<input type="checkbox"/>
OUTSIDE	<input type="checkbox"/>	<input type="checkbox"/>	<input type="checkbox"/>	<input type="checkbox"/>	<input type="checkbox"/>
CTRL A/C	<input type="checkbox"/>	<input checked="" type="checkbox"/>	<input checked="" type="checkbox"/>	<input type="checkbox"/>	<input type="checkbox"/>
PLUMBING					<input checked="" type="checkbox"/>
X FULL BATH					
X HALF BATH					
X FIXTURES					

<b>SUBTOTAL</b>		151,290
MULTI-FAMILY #	0	0
BUILDING TYPE	100%	0
BSMT FINISH	0 S.F.	0
FIREPLACE #	0	0
HEATING	0 S.F.	0
AIR COND	960 S.F.	1,580
PLUMBING #	0	0
GARAGES & CARPORTS		0
EXTRA FEATURES		5,600
<b>SUBTOTAL</b>		158,470
GRADE FACTOR		95 %
<b>UNADJUSTED VALUE</b>		150,550
FACTOR		100 %

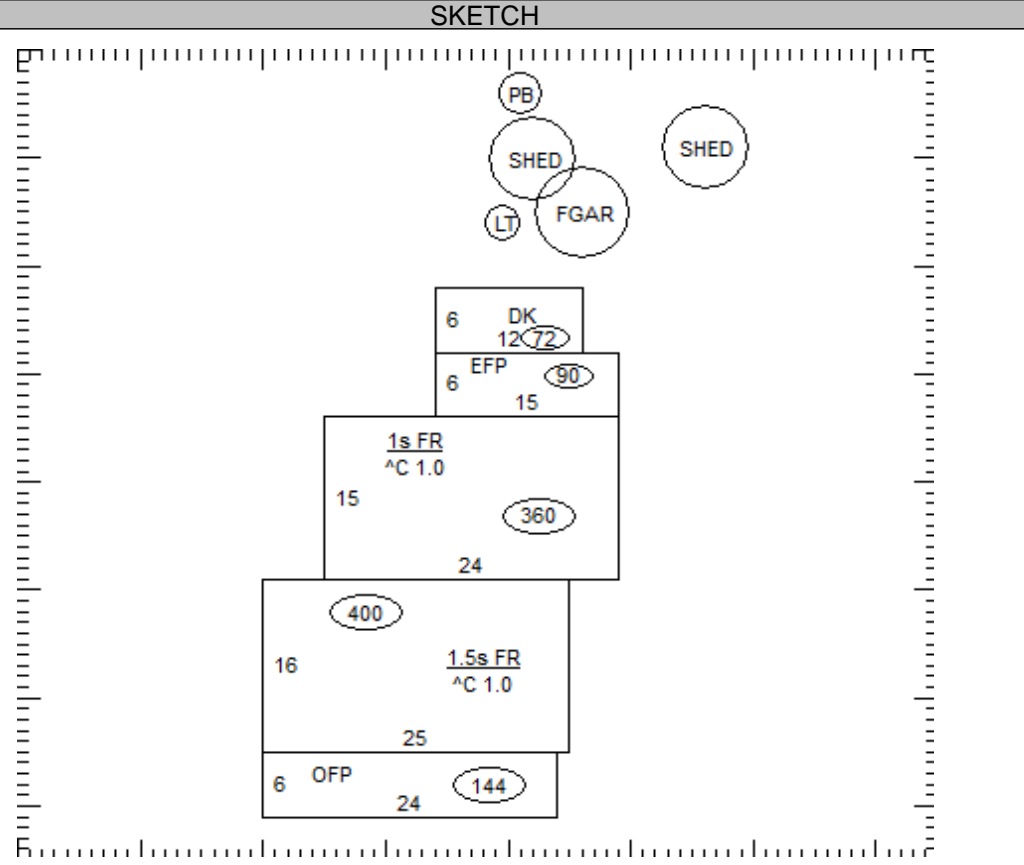

OCCUPANCY	ST.HT	SIZE	AREA	GRADE	PRICE	AGE	REMD	CND	UNADJ VAL	PHYS	PHYS VAL	FUNC	TRUE VAL
DWELLING	1.5	SK	960	C-		1900		A	150,550	45	82,800		70,400
1 Lean - To	7	21x24	504	C	4.80	1999		A	2,420	37	1,520		1,500
2 Gar - Frame		20x24	480	C	23.70	1930	1999	A	11,380	95	570		600
3 Shed		18x38	684	D	5.28	2000		A	3,610	38	2,240		2,200
4 Pole Bldg		30x40	1,200	C	15.89	2011		A	19,070	19	15,450		15,500
5 Shed	PP	10x10	100	C		2000		A		37			0
6													
7													
8													
9													
10													
11													

42-002200.0000 TOTAL 90,200

**COMMENTS**

>>OB Features: 1.4 <Add Concrete Floor>  
 Dwelling has an Economic Factor of 85%

42-002200.0000

LEGAL INFORMATION

OUT E1/2 SE

RTS: 001-06-02

Acres:2.7500

LITMER JOSHUA P & MILLER ALLIE R

LITMER JOSHUA P & MILLER ALLIE R

2492 STATE ROUTE 29

CELINA, OH 45822

	OWNERSHIP	ADDRESS	CITY	STATE	ZIP	DATE	AMOUNT	DEED:CONV#	JS	VALID
1	GRIESHOP MICHAEL	5894 ST RTE 119	SAINT HENRY	OH	45883	10/02/2009	23,500	WDC : A : 574	<input type="checkbox"/>	<input type="checkbox"/>
2	MIDWEST HOME FINDERS, INC	4008 LEWIS	TOLEDO	OH	43612	08/06/2009	0	QCE : X : 0	<input type="checkbox"/>	<input type="checkbox"/>
3	SECRETARY OF HOUSING &	15 E SEVENTH ST	CINCINNATI	OH	45202	08/08/2008	0	QCE : X : 0	<input type="checkbox"/>	<input type="checkbox"/>

X:	<input type="checkbox"/> TTO	LISTER: JL	DATE: 06/07/2012	TIME: 12:00:00 AM	<input type="checkbox"/> LETTER	<input type="checkbox"/> LETTER REC'D	GIS CODE
----	------------------------------	------------	------------------	-------------------	---------------------------------	---------------------------------------	----------

STREET/ROAD	TOPOGRAPHY	PU-UTILITIES-PR	NEIGHBORHOOD	INFLUENCE FACTORS		PROPERTY LOCATION	
2492 ST RT 29, CELINA	<input checked="" type="checkbox"/> PAVED <input type="checkbox"/> GRAVEL <input type="checkbox"/> DIRT <input type="checkbox"/> SIDEWALKS <input type="checkbox"/> CURBS	<input checked="" type="checkbox"/> LEVEL <input type="checkbox"/> HIGH <input type="checkbox"/> LOW <input type="checkbox"/> ROLLING <input type="checkbox"/> STANDARD	<input type="checkbox"/> WATER <input type="checkbox"/> SEWER <input checked="" type="checkbox"/> GAS <input checked="" type="checkbox"/> ELECTRIC <input type="checkbox"/> STANDARD	<input type="checkbox"/> IMPROVING <input checked="" type="checkbox"/> STATIC <input type="checkbox"/> DECLINING <input type="checkbox"/> OLD <input type="checkbox"/> STANDARD	<input type="checkbox"/> A. NO ROAD <input type="checkbox"/> B. TOPGRHY <input type="checkbox"/> C. Ex Front <input type="checkbox"/> D. QUANTITY <input type="checkbox"/> E. SZ/SHAPE	<input type="checkbox"/> F. RESTRICT <input type="checkbox"/> G. WOOD LT <input type="checkbox"/> H. VACANCY <input type="checkbox"/> I. WATER FRONT <input type="checkbox"/> J. OTHER/CDU	2492 ST RT 29, CELINA COMMENT

LAND COMPUTATIONS

LAND TYPE	SIZE	M	RATE	C	INF	M	VALUE	C
Total Acres: 2.7500						TOTAL	36,900	0

VALUATION SUMMARY

VALUE YEAR	REASON FOR CHANGE	APPRaised	LAND IMPR	VALUE	ASSESSED	LAND IMPR	VALUE

OCCUPANCY	EXTERIOR	FLOOR	AREA	CONST	VALUE
<input type="checkbox"/> SF <input type="checkbox"/> DU <input type="checkbox"/> TR	<input type="checkbox"/> WOOD				
<input type="checkbox"/> CONVERSION	<input type="checkbox"/> STUCCO				
<b>BUILDING TYPE</b>	<input type="checkbox"/> ALM/VYNL				
<input type="checkbox"/> MOBILE HOME	<input type="checkbox"/> CONC BLK				
<input type="checkbox"/> BI/TR LEVEL	<input type="checkbox"/> METAL				
<input type="checkbox"/> MOD/MAN	<input type="checkbox"/> BRICK				
<input type="checkbox"/> _____	<input type="checkbox"/> STONE				
ROOFING	ROOF TYPE				
<input type="checkbox"/> METAL	<input type="checkbox"/> GABLE				
<input type="checkbox"/> SLT/TLE	<input type="checkbox"/> HIP				
<input type="checkbox"/> SHINGLES	<input type="checkbox"/> GAMBREL				
<input type="checkbox"/> SHAKES	<input type="checkbox"/> MANSARD				
<input type="checkbox"/> COMPOSITE	<input type="checkbox"/> FLAT				
SUBTOTAL					0
MULTI-FAMILY #		0			0
BUILDING TYPE		000%			0
BSMT FINISH		0 S.F.			0
FIREPLACE #		0			0
HEATING		0 S.F.			0
AIR COND		0 S.F.			0
PLUMBING #		0			0
GARAGES & CARPORTS					0
EXTRA FEATURES					0
SUBTOTAL					0
GRADE FACTOR					%
UNADJUSTED VALUE					0
FACTOR					%

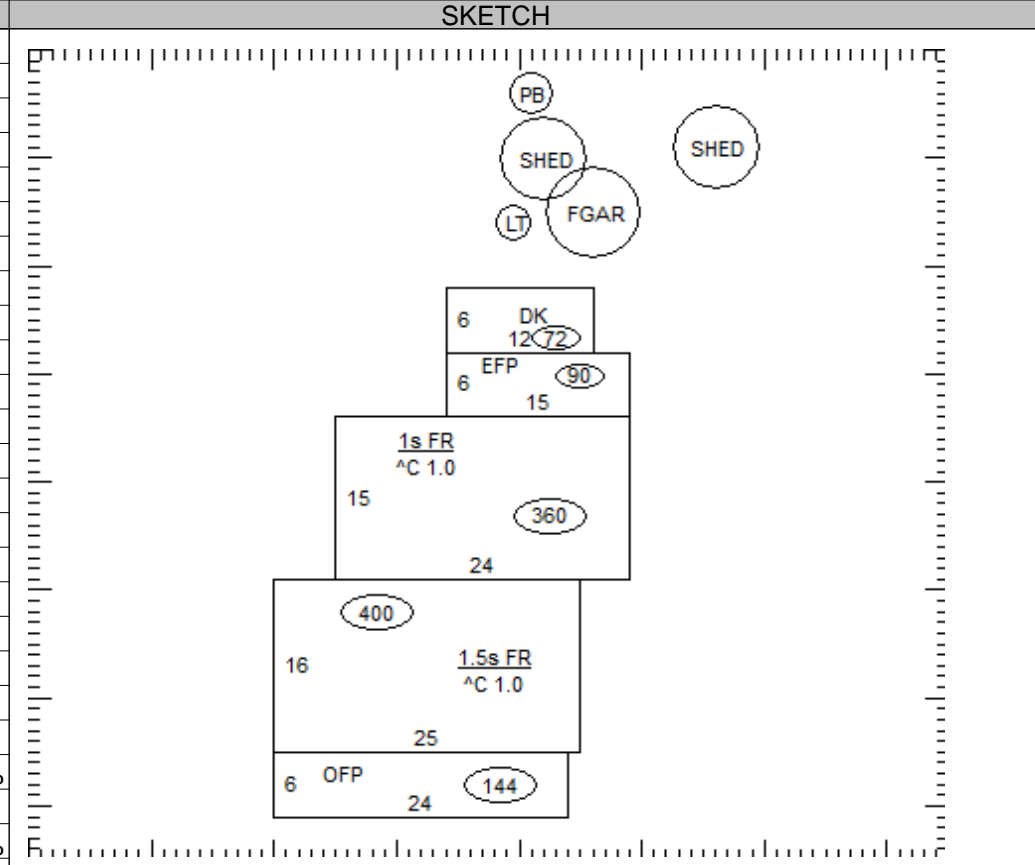

OCCUPANCY	ST.HT	SIZE	AREA	GRADE	PRICE	AGE	REMD	CND	UNADJ VAL	PHYS	PHYS VAL	FUNC	TRUE VAL
DWELLING		SK											
1													
2													
3													
4													
5													
6													
7													
8													
9													
10													
11													

42-002200.0000

TOTAL 0

COMMENTS

WASHINGTON TWP / CELINA SD

07-02-400-004

Property Class: 510

Neighborhood

009425-R150

Map: 01

Block: 01

Card: 03

Bk: Pg:

42-002200.0000

LITMER JOSHUA P & MILLER ALLIE R

LITMER JOSHUA P & MILLER ALLIE R

2492 STATE ROUTE 29

CELINA, OH 45822

LEGAL INFORMATION

OUT E1/2 SE

RTS: 001-06-02

Acres:2.7500

	OWNERSHIP	ADDRESS	CITY	STATE	ZIP	DATE	AMOUNT	DEED:CONV#	JS	VALID
1	HAGUE SUSAN C	2492 ST RT 29	CELINA	OH	45822	01/02/2003	75,000	: A : 0	<input type="checkbox"/>	<input checked="" type="checkbox"/>
2							0	0	<input type="checkbox"/>	<input type="checkbox"/>
3							0	0	<input type="checkbox"/>	<input type="checkbox"/>

X:  TTO LISTER: JL DATE: 06/07/2012 TIME: 12:00:00 AM  LETTER  LETTER REC'D GIS CODE

STREET/ROAD	TOPOGRAPHY	PU-UTILITIES-PR	NEIGHBORHOOD	INFLUENCE FACTORS	PROPERTY LOCATION	
<input checked="" type="checkbox"/> PAVED <input type="checkbox"/> GRAVEL <input type="checkbox"/> DIRT <input type="checkbox"/> SIDEWALKS <input type="checkbox"/> CURBS	<input checked="" type="checkbox"/> LEVEL <input type="checkbox"/> HIGH <input type="checkbox"/> LOW <input type="checkbox"/> ROLLING <input type="checkbox"/> STANDARD	<input type="checkbox"/> WATER <input type="checkbox"/> SEWER <input checked="" type="checkbox"/> GAS <input checked="" type="checkbox"/> ELECTRIC <input type="checkbox"/> STANDARD	<input type="checkbox"/> IMPROVING <input checked="" type="checkbox"/> STATIC <input type="checkbox"/> DECLINING <input type="checkbox"/> OLD <input type="checkbox"/> STANDARD	<input type="checkbox"/> A. NO ROAD <input type="checkbox"/> B. TOPGRHY <input type="checkbox"/> C. Ex Front <input type="checkbox"/> D. QUANTITY <input type="checkbox"/> E. SZ/SHAPE	<input type="checkbox"/> F. RESTRICT <input type="checkbox"/> G. WOOD LT <input type="checkbox"/> H. VACANCY <input type="checkbox"/> I. WATER FRONT <input type="checkbox"/> J. OTHER/CDU	2492 ST RT 29, CELINA COMMENT

LAND COMPUTATIONS							
LAND TYPE	SIZE	M	RATE	C	INF	M	VALUE C
Total Acres: 2.7500					TOTAL		36,900 0

VALUATION SUMMARY

VALUE YEAR	REASON FOR CHANGE	APPRaised	IMPR	TOTAL	ASSESSED	IMPR	TOTAL

OCCUPANCY  SF  DU  TR  
 CONVERSION  
**BUILDING TYPE**  
 MOBILE HOME  
 BI/TR LEVEL  
 MOD/MAN  
 \_\_\_\_\_

FLOOR	AREA	CONST	VALUE

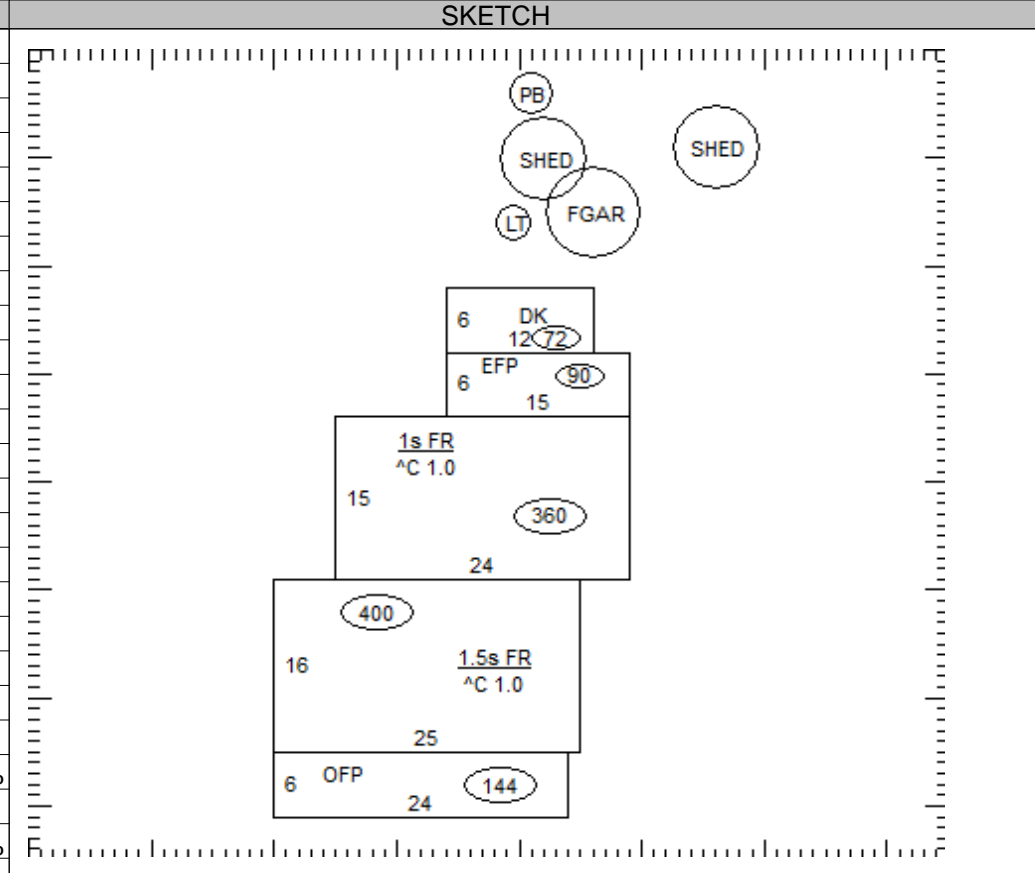

**ROOFING**      **ROOF TYPE**

METAL       GABLE  
 SLT/TLE       HIP  
 SHINGLES       GAMBREL  
 SHAKES       MANSARD  
 COMPOSITE       FLAT

<b>SUBTOTAL</b>			0
MULTI-FAMILY #	0		0
BUILDING TYPE	000%		0
BSMT FINISH	0 S.F.		0
FIREPLACE #	0		0
HEATING	0 S.F.		0
AIR COND	0 S.F.		0
PLUMBING #	0		0
GARAGES & CARPORTS			0
EXTRA FEATURES			0
<b>SUBTOTAL</b>			0
GRADE FACTOR			%
<b>UNADJUSTED VALUE</b>			0
FACTOR			%

**FLOORS**      B    1    2    3    U

CONCRETE            
WOOD                  
TILE/COMPO          
CARPET        

**INT. FINISH**      B    1    2    3    U

PLASTER/DW          
PANELING              
UNFINISHED   

**ACCOMMODATIONS**

# OF ROOMS            
BEDROOMS              
FIREPLACES            
HEAT & AC        B    1    2    3    U

NO HEAT                  
CTRL HEAT               
HW/STEAM               
ELECTRIC                
HEAT PUMP              
FLR/WALL               
STVE/SPCE              
GEOTHERMAL            
OUTSIDE                 
CTRL A/C         

**PLUMBING**      BASE

X FULL BATH            
X HALF BATH            
X FIXTURES       

OCCUPANCY	ST.HT	SIZE	AREA	GRADE	PRICE	AGE	REMD	CND	UNADJ VAL	PHYS	PHYS VAL	FUNC	TRUE VAL
DWELLING		SK											
1													
2													
3													
4													
5													
6													
7													
8													
9													
10													
11													

42-002200.0000 TOTAL      0

**COMMENTS**