

42-001600.0500

MARCHAL DOUG J & KENDRA L

MARCHAL DOUG J & KENDRA L

6790 BURRVILLE RD

CELINA, OH 45822

LEGAL INFORMATION

W SD SW NW

RTS: 001-06-02

Acres:2.0000

| | OWNERSHIP | ADDRESS | CITY | STATE | ZIP | DATE | AMOUNT | DEED:CONV# | JS | VALID |
|---|-------------------------|-------------------|--------|-------|-------|------------|---------|-------------|--------------------------|-------------------------------------|
| 1 | MARCHAL DOUG J & KENDRA | 6790 BURRVILLE RD | CELINA | OH | 45822 | 04/26/2019 | 285,000 | WDC : 259 | <input type="checkbox"/> | <input checked="" type="checkbox"/> |
| 2 | ROEDIGER NICKOLAS A & | 6790 BURRVILLE RD | CELINA | OH | 45822 | 06/28/2005 | 140,000 | WDC : A : 0 | <input type="checkbox"/> | <input type="checkbox"/> |
| 3 | HOMAN ROSALIE M | 6790 BURRVILLE RD | CELINA | OH | 45822 | 02/07/2005 | 0 | : A : 0 | <input type="checkbox"/> | <input checked="" type="checkbox"/> |

X: TTO LISTER: CL DATE: 06/11/2004 TIME: 10:57:24 AM LETTER LETTER REC'D GIS CODE Minor Sub

| STREET/ROAD | TOPOGRAPHY | PU-UTILITIES-PR | NEIGHBORHOOD | INFLUENCE FACTORS | PROPERTY LOCATION | |
|---|---|---|---|--|--|--|
| <input checked="" type="checkbox"/> PAVED <input type="checkbox"/> GRAVEL <input type="checkbox"/> DIRT <input type="checkbox"/> SIDEWALKS <input type="checkbox"/> CURBS | <input checked="" type="checkbox"/> LEVEL <input type="checkbox"/> HIGH <input type="checkbox"/> LOW <input type="checkbox"/> ROLLING <input type="checkbox"/> STANDARD | <input type="checkbox"/> WATER <input type="checkbox"/> SEWER <input type="checkbox"/> GAS <input checked="" type="checkbox"/> ELECTRIC <input type="checkbox"/> STANDARD | <input type="checkbox"/> IMPROVING <input checked="" type="checkbox"/> STATIC <input type="checkbox"/> DECLINING <input type="checkbox"/> OLD <input type="checkbox"/> STANDARD | <input type="checkbox"/> A. NO ROAD <input type="checkbox"/> B. TOPGRHY <input type="checkbox"/> C. Ex Front <input type="checkbox"/> D. QUANTITY <input type="checkbox"/> E. SZ/SHAPE | <input type="checkbox"/> F. RESTRICT <input type="checkbox"/> G. WOOD LT <input type="checkbox"/> H. VACANCY <input type="checkbox"/> I. WATER FRONT <input type="checkbox"/> J. OTHER/CDU | 6790 BURRVILLE RD, CELINA COMMENT TY2022:Net Gen=\$2,445.16, Other Assessment=\$54.64 DE17 DESKTOP RVW CHG: COR EX FEATURES |

| LAND COMPUTATIONS | | | | | | | | |
|---------------------|------|-------|------|---|-----|---------|--------|---|
| LAND TYPE | SIZE | M | RATE | C | INF | M VALUE | C | |
| HS:Home Site | AC:1 | 22370 | | | | 22,400 | 0 | |
| SM:Small Acreage | AC:1 | 8500 | | | | 8,500 | 0 | |
| Total Acres: 2.0000 | | | | | | TOTAL | 30,900 | 0 |

| VALUATION SUMMARY | | | | | |
|-------------------|----------------------|---------|---------|---------|--|
| VALUE YEAR | 2023 | 2020 | 2017 | 2017 | |
| REASON FOR CHANGE | RAPP | RAPP | RAPP | MISC | |
| APPRaised | <u>LAND</u> 30,900 | 26,100 | 23,500 | 18,800 | |
| VALUE | <u>IMPR</u> 175,700 | 125,700 | 111,400 | 107,600 | |
| | <u>TOTAL</u> 206,600 | 151,800 | 134,900 | 126,400 | |
| ASSESSED | <u>LAND</u> 10,820 | 9,140 | 8,230 | 6,580 | |
| VALUE | <u>IMPR</u> 61,500 | 44,000 | 38,990 | 37,660 | |
| | <u>TOTAL</u> 72,320 | 53,140 | 47,220 | 44,240 | |

| | | | |
|--|-----------------------------------|--|-------------------------------|
| OCCUPANCY | | EXTERIOR | |
| <input checked="" type="checkbox"/> SF | <input type="checkbox"/> DU | <input type="checkbox"/> TR | <input type="checkbox"/> WOOD |
| <input type="checkbox"/> CONVERSION | <input type="checkbox"/> STUCCO | | |
| BUILDING TYPE | | <input checked="" type="checkbox"/> ALM/VYNL | |
| <input type="checkbox"/> MOBILE HOME | <input type="checkbox"/> CONC BLK | | |
| <input type="checkbox"/> BI/TR LEVEL | <input type="checkbox"/> METAL | | |
| <input type="checkbox"/> MOD/MAN | <input type="checkbox"/> BRICK | | |
| <input type="checkbox"/> | <input type="checkbox"/> STONE | | |

| | | | |
|--|---|------------------|--|
| ROOFING | | ROOF TYPE | |
| <input type="checkbox"/> METAL | <input checked="" type="checkbox"/> GABLE | | |
| <input type="checkbox"/> SLT/TLE | <input type="checkbox"/> HIP | | |
| <input checked="" type="checkbox"/> SHINGLES | <input type="checkbox"/> GAMBREL | | |
| <input type="checkbox"/> SHAKES | <input type="checkbox"/> MANSARD | | |
| <input type="checkbox"/> COMPOSITE | <input type="checkbox"/> FLAT | | |

| | | | | | | |
|---------------|-------------------------------------|-------------------------------------|--------------------------|--------------------------|--------------------------|--------------------------|
| FLOORS | | B | 1 | 2 | 3 | U |
| CONCRETE | <input checked="" type="checkbox"/> | <input type="checkbox"/> | <input type="checkbox"/> | <input type="checkbox"/> | <input type="checkbox"/> | <input type="checkbox"/> |
| WOOD | <input type="checkbox"/> | <input checked="" type="checkbox"/> | <input type="checkbox"/> | <input type="checkbox"/> | <input type="checkbox"/> | <input type="checkbox"/> |
| TILE/COMPO | <input type="checkbox"/> | <input checked="" type="checkbox"/> | <input type="checkbox"/> | <input type="checkbox"/> | <input type="checkbox"/> | <input type="checkbox"/> |
| CARPET | <input type="checkbox"/> | <input checked="" type="checkbox"/> | <input type="checkbox"/> | <input type="checkbox"/> | <input type="checkbox"/> | <input type="checkbox"/> |

| | | | | | | |
|--------------------|-------------------------------------|-------------------------------------|--------------------------|--------------------------|--------------------------|--------------------------|
| INT. FINISH | | B | 1 | 2 | 3 | U |
| PLASTER/DW | <input type="checkbox"/> | <input checked="" type="checkbox"/> | <input type="checkbox"/> | <input type="checkbox"/> | <input type="checkbox"/> | <input type="checkbox"/> |
| PANELING | <input type="checkbox"/> | <input type="checkbox"/> | <input type="checkbox"/> | <input type="checkbox"/> | <input type="checkbox"/> | <input type="checkbox"/> |
| UNFINISHED | <input checked="" type="checkbox"/> | <input type="checkbox"/> | <input type="checkbox"/> | <input type="checkbox"/> | <input type="checkbox"/> | <input type="checkbox"/> |

| | | | | | | |
|-----------------------|--|---|--|--|--|--|
| ACCOMMODATIONS | | | | | | |
| # OF ROOMS | | 5 | | | | |
| BEDROOMS | | 3 | | | | |
| FIREPLACES | | | | | | |

| | | | | | | |
|----------------------|--------------------------|-------------------------------------|--------------------------|--------------------------|--------------------------|--------------------------|
| HEAT & AC | | B | 1 | 2 | 3 | U |
| NO HEAT | <input type="checkbox"/> | <input type="checkbox"/> | <input type="checkbox"/> | <input type="checkbox"/> | <input type="checkbox"/> | <input type="checkbox"/> |
| CTRL HEAT | <input type="checkbox"/> | <input checked="" type="checkbox"/> | <input type="checkbox"/> | <input type="checkbox"/> | <input type="checkbox"/> | <input type="checkbox"/> |
| HW/STEAM | <input type="checkbox"/> | <input type="checkbox"/> | <input type="checkbox"/> | <input type="checkbox"/> | <input type="checkbox"/> | <input type="checkbox"/> |
| ELECTRIC | <input type="checkbox"/> | <input type="checkbox"/> | <input type="checkbox"/> | <input type="checkbox"/> | <input type="checkbox"/> | <input type="checkbox"/> |
| HEAT PUMP | <input type="checkbox"/> | <input type="checkbox"/> | <input type="checkbox"/> | <input type="checkbox"/> | <input type="checkbox"/> | <input type="checkbox"/> |
| FLR/WALL | <input type="checkbox"/> | <input type="checkbox"/> | <input type="checkbox"/> | <input type="checkbox"/> | <input type="checkbox"/> | <input type="checkbox"/> |
| STVE/SPCE | <input type="checkbox"/> | <input type="checkbox"/> | <input type="checkbox"/> | <input type="checkbox"/> | <input type="checkbox"/> | <input type="checkbox"/> |
| GEO THERMAL | <input type="checkbox"/> | <input type="checkbox"/> | <input type="checkbox"/> | <input type="checkbox"/> | <input type="checkbox"/> | <input type="checkbox"/> |
| OUTSIDE | <input type="checkbox"/> | <input type="checkbox"/> | <input type="checkbox"/> | <input type="checkbox"/> | <input type="checkbox"/> | <input type="checkbox"/> |
| CTRL A/C | <input type="checkbox"/> | <input checked="" type="checkbox"/> | <input type="checkbox"/> | <input type="checkbox"/> | <input type="checkbox"/> | <input type="checkbox"/> |

| | | | | | | |
|-----------------|--|---|--|--|--|--|
| PLUMBING | | BASE <input checked="" type="checkbox"/> | | | | |
| X FULL BATH | | 1 | | | | |
| X HALF BATH | | | | | | |
| X FIXTURES | | | | | | |

| FLOOR | AREA | CONST | VALUE |
|-------------------------|------------|-------|---------|
| 1 | 1484 | FR | 201,590 |
| BSMT | 1484 | | 21,220 |
| SUBTOTAL | | | 222,810 |
| MULTI-FAMILY # | 0 | | 0 |
| BUILDING TYPE | 100% | | 0 |
| BSMT FINISH | 0 S.F. | | 0 |
| FIREPLACE # | 0 | | 0 |
| HEATING | 0 S.F. | | 0 |
| AIR COND | 1,484 S.F. | | 2,450 |
| PLUMBING # | 3 | | 3,630 |
| GARAGES & CARPORTS | | | 18,000 |
| EXTRA FEATURES | | | 12,600 |
| SUBTOTAL | | | 259,490 |
| GRADE FACTOR | | | 100 % |
| UNADJUSTED VALUE | | | 259,490 |
| FACTOR | | | 100 % |

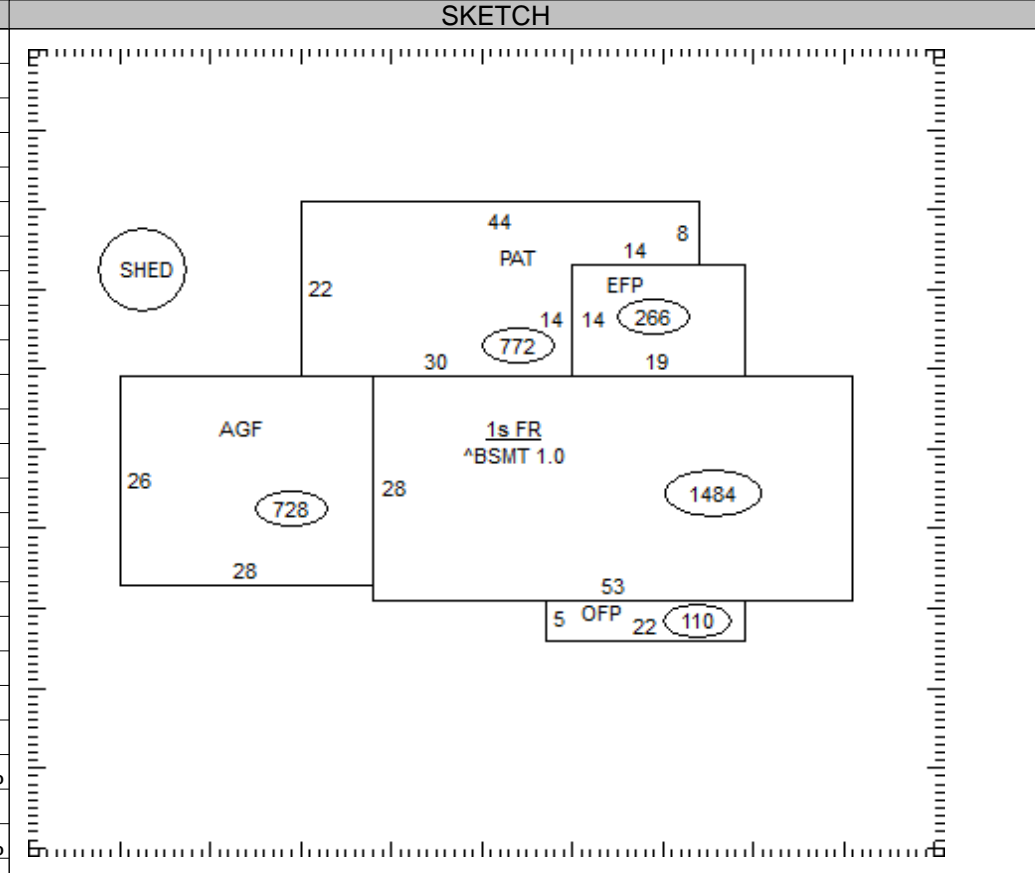

| OCCUPANCY | ST.HT | SIZE | AREA | GRADE | PRICE | AGE | REMD | CND | UNADJ VAL | PHYS | PHYS VAL | FUNC | TRUE VAL |
|-----------|-------|-------|-------|-------|-------|------|------|-----|-----------|------|----------|------|----------|
| DWELLING | 1 | SK | 1,484 | C | | 1998 | | A | 259,490 | 22 | 202,400 | | 172,000 |
| 1 Shed | 12 | 28x32 | 896 | C | 6.60 | 1998 | | A | 5,910 | 37 | 3,720 | | 3,700 |
| 2 | | | | | | | | | | | | | |
| 3 | | | | | | | | | | | | | |
| 4 | | | | | | | | | | | | | |
| 5 | | | | | | | | | | | | | |
| 6 | | | | | | | | | | | | | |
| 7 | | | | | | | | | | | | | |
| 8 | | | | | | | | | | | | | |
| 9 | | | | | | | | | | | | | |
| 10 | | | | | | | | | | | | | |
| 11 | | | | | | | | | | | | | |

42-001600.0500

TOTAL 175,700

COMMENTS

Dwelling has an Economic Factor of 85% (Rollback Basis=\$194,400)

WASHINGTON TWP / CELINA SD

07-02-100-009

Property Class: 510

Neighborhood
009425-R150

Map:
Block:
Card:

Bk: Pg:

42-001600.0500

LEGAL INFORMATION

W SD SW NW

RTS: 001-06-02
Acres:2.0000

MARCHAL DOUG J & KENDRA L

MARCHAL DOUG J & KENDRA L

6790 BURRVILLE RD

CELINA, OH 45822

| | OWNERSHIP | ADDRESS | CITY | STATE | ZIP | DATE | AMOUNT | DEED:CONV# | JS | VALID |
|---|--------------------------|-------------------|--------|-------|-------|------------|--------|------------|--------------------------|-------------------------------------|
| 1 | HOMAN HAROLD J & ROSALIE | 6790 BURRVILLE RD | CELINA | OH | 45822 | 06/24/1998 | 0 | : A : 0 | <input type="checkbox"/> | <input checked="" type="checkbox"/> |
| 2 | | | | | | | 0 | 0 | <input type="checkbox"/> | <input type="checkbox"/> |
| 3 | | | | | | | 0 | 0 | <input type="checkbox"/> | <input type="checkbox"/> |

X: TTO LISTER: CL DATE: 06/11/2004 TIME: 10:57:24 AM LETTER LETTER REC'D GIS CODE Minor Sub

| STREET/ROAD | TOPOGRAPHY | PU-UTILITIES-PR | NEIGHBORHOOD | INFLUENCE FACTORS | PROPERTY LOCATION | |
|---|---|---|---|--|--|---|
| <input checked="" type="checkbox"/> PAVED <input type="checkbox"/> GRAVEL <input type="checkbox"/> DIRT <input type="checkbox"/> SIDEWALKS <input type="checkbox"/> CURBS | <input checked="" type="checkbox"/> LEVEL <input type="checkbox"/> HIGH <input type="checkbox"/> LOW <input type="checkbox"/> ROLLING <input type="checkbox"/> STANDARD | <input type="checkbox"/> WATER <input type="checkbox"/> SEWER <input type="checkbox"/> GAS <input checked="" type="checkbox"/> ELECTRIC <input type="checkbox"/> STANDARD | <input type="checkbox"/> IMPROVING <input checked="" type="checkbox"/> STATIC <input type="checkbox"/> DECLINING <input type="checkbox"/> OLD <input type="checkbox"/> STANDARD | <input type="checkbox"/> A. NO ROAD <input type="checkbox"/> B. TOPGRHY <input type="checkbox"/> C. Ex Front <input type="checkbox"/> D. QUANTITY <input type="checkbox"/> E. SZ/SHAPE | <input type="checkbox"/> F. RESTRICT <input type="checkbox"/> G. WOOD LT <input type="checkbox"/> H. VACANCY <input type="checkbox"/> I. WATER FRONT <input type="checkbox"/> J. OTHER/CDU | 6790 BURRVILLE RD, CELINA COMMENT |

| LAND COMPUTATIONS | | | | | | | |
|---------------------|------|---|------|---|-------|--------|---------|
| LAND TYPE | SIZE | M | RATE | C | INF | M | VALUE C |
| | | | | | | | |
| | | | | | | | |
| | | | | | | | |
| | | | | | | | |
| | | | | | | | |
| | | | | | | | |
| | | | | | | | |
| | | | | | | | |
| | | | | | | | |
| Total Acres: 2.0000 | | | | | TOTAL | 30,900 | 0 |

VALUATION SUMMARY

| VALUE YEAR | | | | | | | |
|-------------------|--------------|--|--|--|--|--|--|
| REASON FOR CHANGE | | | | | | | |
| APPRaised | <u>LAND</u> | | | | | | |
| VALUE | <u>IMPR</u> | | | | | | |
| | <u>TOTAL</u> | | | | | | |
| ASSESSED | <u>LAND</u> | | | | | | |
| VALUE | <u>IMPR</u> | | | | | | |
| | <u>TOTAL</u> | | | | | | |

| OCCUPANCY | EXTERIOR | FLOOR | AREA | CONST | VALUE |
|---|-----------------------------------|-------|------|-------|-------|
| <input type="checkbox"/> SF <input type="checkbox"/> DU <input type="checkbox"/> TR | <input type="checkbox"/> WOOD | | | | |
| <input type="checkbox"/> CONVERSION | <input type="checkbox"/> STUCCO | | | | |
| BUILDING TYPE | <input type="checkbox"/> ALM/VYNL | | | | |
| <input type="checkbox"/> MOBILE HOME | <input type="checkbox"/> CONC BLK | | | | |
| <input type="checkbox"/> BI/TR LEVEL | <input type="checkbox"/> METAL | | | | |
| <input type="checkbox"/> MOD/MAN | <input type="checkbox"/> BRICK | | | | |
| <input type="checkbox"/> | <input type="checkbox"/> STONE | | | | |

| ROOFING | ROOF TYPE |
|------------------------------------|----------------------------------|
| <input type="checkbox"/> METAL | <input type="checkbox"/> GABLE |
| <input type="checkbox"/> SLT/TLE | <input type="checkbox"/> HIP |
| <input type="checkbox"/> SHINGLES | <input type="checkbox"/> GAMBREL |
| <input type="checkbox"/> SHAKES | <input type="checkbox"/> MANSARD |
| <input type="checkbox"/> COMPOSITE | <input type="checkbox"/> FLAT |

| FLOORS | B | 1 | 2 | 3 | U |
|----------------|-------------------------------|--------------------------|--------------------------|--------------------------|--------------------------|
| CONCRETE | <input type="checkbox"/> | <input type="checkbox"/> | <input type="checkbox"/> | <input type="checkbox"/> | <input type="checkbox"/> |
| WOOD | <input type="checkbox"/> | <input type="checkbox"/> | <input type="checkbox"/> | <input type="checkbox"/> | <input type="checkbox"/> |
| TILE/COMPO | <input type="checkbox"/> | <input type="checkbox"/> | <input type="checkbox"/> | <input type="checkbox"/> | <input type="checkbox"/> |
| CARPET | <input type="checkbox"/> | <input type="checkbox"/> | <input type="checkbox"/> | <input type="checkbox"/> | <input type="checkbox"/> |
| INT. FINISH | B | 1 | 2 | 3 | U |
| PLASTER/DW | <input type="checkbox"/> | <input type="checkbox"/> | <input type="checkbox"/> | <input type="checkbox"/> | <input type="checkbox"/> |
| PANELING | <input type="checkbox"/> | <input type="checkbox"/> | <input type="checkbox"/> | <input type="checkbox"/> | <input type="checkbox"/> |
| UNFINISHED | <input type="checkbox"/> | <input type="checkbox"/> | <input type="checkbox"/> | <input type="checkbox"/> | <input type="checkbox"/> |
| ACCOMMODATIONS | | | | | |
| # OF ROOMS | | | | | |
| BEDROOMS | | | | | |
| FIREPLACES | | | | | |
| HEAT & AC | B | 1 | 2 | 3 | U |
| NO HEAT | <input type="checkbox"/> | <input type="checkbox"/> | <input type="checkbox"/> | <input type="checkbox"/> | <input type="checkbox"/> |
| CTRL HEAT | <input type="checkbox"/> | <input type="checkbox"/> | <input type="checkbox"/> | <input type="checkbox"/> | <input type="checkbox"/> |
| HW/STEAM | <input type="checkbox"/> | <input type="checkbox"/> | <input type="checkbox"/> | <input type="checkbox"/> | <input type="checkbox"/> |
| ELECTRIC | <input type="checkbox"/> | <input type="checkbox"/> | <input type="checkbox"/> | <input type="checkbox"/> | <input type="checkbox"/> |
| HEAT PUMP | <input type="checkbox"/> | <input type="checkbox"/> | <input type="checkbox"/> | <input type="checkbox"/> | <input type="checkbox"/> |
| FLR/WALL | <input type="checkbox"/> | <input type="checkbox"/> | <input type="checkbox"/> | <input type="checkbox"/> | <input type="checkbox"/> |
| STVE/SPCE | <input type="checkbox"/> | <input type="checkbox"/> | <input type="checkbox"/> | <input type="checkbox"/> | <input type="checkbox"/> |
| GEOTHERMAL | <input type="checkbox"/> | <input type="checkbox"/> | <input type="checkbox"/> | <input type="checkbox"/> | <input type="checkbox"/> |
| OUTSIDE | <input type="checkbox"/> | <input type="checkbox"/> | <input type="checkbox"/> | <input type="checkbox"/> | <input type="checkbox"/> |
| CTRL A/C | <input type="checkbox"/> | <input type="checkbox"/> | <input type="checkbox"/> | <input type="checkbox"/> | <input type="checkbox"/> |
| PLUMBING | BASE <input type="checkbox"/> | | | | |
| X FULL BATH | | | | | |
| X HALF BATH | | | | | |
| X FIXTURES | | | | | |

| | | |
|-------------------------|--------|---|
| SUBTOTAL | | 0 |
| MULTI-FAMILY # | 0 | 0 |
| BUILDING TYPE | 000% | 0 |
| BSMT FINISH | 0 S.F. | 0 |
| FIREPLACE # | 0 | 0 |
| HEATING | 0 S.F. | 0 |
| AIR COND | 0 S.F. | 0 |
| PLUMBING # | 0 | 0 |
| GARAGES & CARPORTS | | 0 |
| EXTRA FEATURES | | 0 |
| SUBTOTAL | | 0 |
| GRADE FACTOR | | % |
| UNADJUSTED VALUE | | 0 |
| FACTOR | | % |

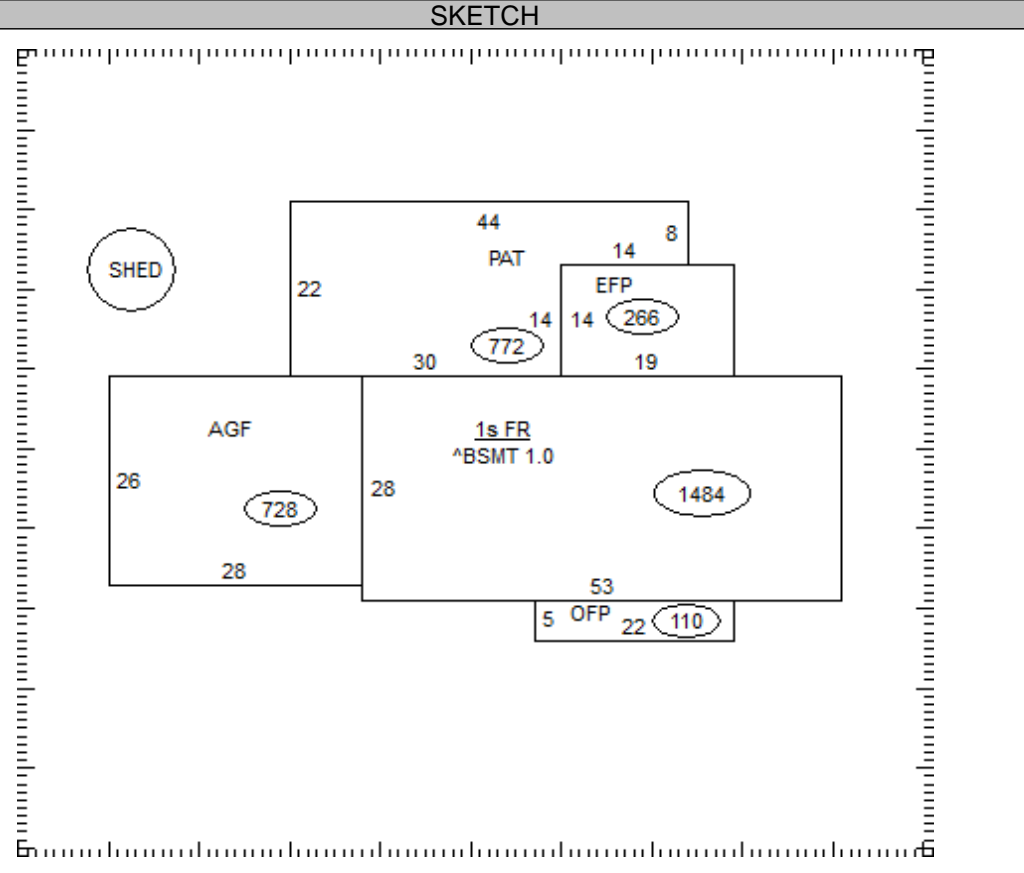

| OCCUPANCY | ST.HT | SIZE | AREA | GRADE | PRICE | AGE | REMD | CND | UNADJ VAL | PHYS | PHYS VAL | FUNC | TRUE VAL |
|-----------|-------|------|------|-------|-------|-----|------|-----|-----------|------|----------|------|----------|
| DWELLING | | SK | | | | | | | | | | | |
| 1 | | | | | | | | | | | | | |
| 2 | | | | | | | | | | | | | |
| 3 | | | | | | | | | | | | | |
| 4 | | | | | | | | | | | | | |
| 5 | | | | | | | | | | | | | |
| 6 | | | | | | | | | | | | | |
| 7 | | | | | | | | | | | | | |
| 8 | | | | | | | | | | | | | |
| 9 | | | | | | | | | | | | | |
| 10 | | | | | | | | | | | | | |
| 11 | | | | | | | | | | | | | |

42-001600.0500

TOTAL 0

COMMENTS