

UNION TWP-MENDON CORP / PARKWAY SD
03-21-427-007

41-017300.0000

LEGAL INFORMATION
DUTTON ADDITION

LOT#: 2

SIANO JOHN D & D'ANNA L
SIANO JOHN D & D'ANNA L
PO BOX 189
MENDON, OH 45862

	OWNERSHIP	ADDRESS	CITY	STATE	ZIP	DATE	AMOUNT	DEED:CONV#	JS	VALID
1	SIANO JOHN D & D'ANNA L	PO BOX 189	MENDON	OH	45862	03/12/2021	31,400	WDC : 179	<input type="checkbox"/>	<input checked="" type="checkbox"/>
2	KEMPER JOSEPH JR	1200 ST JOHNS RD	MARIA STEIN	OH	45860	11/30/2000	31,400	: A : 0	<input type="checkbox"/>	<input checked="" type="checkbox"/>
3							0	0	<input type="checkbox"/>	<input type="checkbox"/>

X: TTO LISTER: CL DATE: 09/20/2004 TIME: 09:36:40 AM LETTER LETTER REC'D GIS CODE

STREET/ROAD	TOPOGRAPHY	PU-UTILITIES-PR	NEIGHBORHOOD	INFLUENCE FACTORS	PROPERTY LOCATION
<input checked="" type="checkbox"/> PAVED <input type="checkbox"/> GRAVEL <input type="checkbox"/> DIRT <input type="checkbox"/> SIDEWALKS <input type="checkbox"/> CURBS	<input checked="" type="checkbox"/> LEVEL <input type="checkbox"/> HIGH <input type="checkbox"/> LOW <input type="checkbox"/> ROLLING <input type="checkbox"/> STANDARD	<input type="checkbox"/> WATER <input type="checkbox"/> SEWER <input type="checkbox"/> GAS <input type="checkbox"/> ELECTRIC <input checked="" type="checkbox"/> STANDARD	<input type="checkbox"/> IMPROVING <input checked="" type="checkbox"/> STATIC <input type="checkbox"/> DECLINING <input type="checkbox"/> OLD <input type="checkbox"/> STANDARD	<input type="checkbox"/> A. NO ROAD <input type="checkbox"/> B. TOPGRHY <input type="checkbox"/> C. Ex Front <input type="checkbox"/> D. QUANTITY <input type="checkbox"/> E. SZ/SHAPE	<input type="checkbox"/> F. RESTRICT <input type="checkbox"/> G. WOOD LT <input type="checkbox"/> H. VACANCY <input type="checkbox"/> I. WATER FRONT <input type="checkbox"/> J. OTHER/CDU
				214 GREEN ST, MENDON	
				COMMENT	
				TY2022:Net Gen=\$645.96, Other Assessment=\$2.00 DE16 REVAL DESKTOP REVIEW CORR SKETCH	

LAND COMPUTATIONS						
LAND TYPE	SIZE	M	RATE	C	INF	M VALUE C
F:Front	F85 D165	ST160 DP105	ADJ168			14,300 0
				TOTAL		14,300 0

VALUATION SUMMARY					
VALUE YEAR		2023	2022	2020	2017
REASON FOR CHANGE		RAPP	REMB	RAPP	RAPP
APPRAISED VALUE	<u>LAND</u>	14,300	11,800	11,800	8,900
	<u>IMPR</u>	44,900	29,100	29,700	28,500
	<u>TOTAL</u>	59,200	40,900	41,500	37,400
ASSESSED VALUE	<u>LAND</u>	5,010	4,130	4,130	3,120
	<u>IMPR</u>	15,720	10,190	10,400	9,980
	<u>TOTAL</u>	20,730	14,320	14,530	13,100

OCCUPANCY		EXTERIOR		FLOOR	AREA	CONST	VALUE						
<input checked="" type="checkbox"/> SF	<input type="checkbox"/> DU	<input type="checkbox"/> TR	<input type="checkbox"/> WOOD	1	660	FR	115,670						
CONVERSION			<input type="checkbox"/> STUCCO	+	0	FR	10,410						
BUILDING TYPE													
<input type="checkbox"/> MOBILE HOME	<input checked="" type="checkbox"/> ALM/VYNL												
<input type="checkbox"/> BI/TR LEVEL	<input type="checkbox"/> CONC BLK												
<input type="checkbox"/> MOD/MAN	<input type="checkbox"/> METAL												
<input type="checkbox"/>	<input type="checkbox"/> BRICK												
	<input type="checkbox"/> STONE												
ROOFING		ROOF TYPE											
<input checked="" type="checkbox"/> METAL		<input checked="" type="checkbox"/> GABLE											
<input type="checkbox"/> SLT/TLE		<input type="checkbox"/> HIP											
<input type="checkbox"/> SHINGLES		<input type="checkbox"/> GAMBREL											
<input type="checkbox"/> SHAKES		<input type="checkbox"/> MANSARD											
<input type="checkbox"/> COMPOSITE		<input type="checkbox"/> FLAT											
FLOORS				B	1	2	3	U					
CONCRETE	<input type="checkbox"/>	<input type="checkbox"/>	<input type="checkbox"/>	<input type="checkbox"/>	<input type="checkbox"/>	<input type="checkbox"/>	<input type="checkbox"/>	<input type="checkbox"/>					
WOOD	<input type="checkbox"/>	<input type="checkbox"/>	<input type="checkbox"/>	<input type="checkbox"/>	<input type="checkbox"/>	<input type="checkbox"/>	<input type="checkbox"/>	<input type="checkbox"/>					
TILE/COMPO	<input type="checkbox"/>	<input checked="" type="checkbox"/>	<input checked="" type="checkbox"/>	<input type="checkbox"/>	<input type="checkbox"/>	<input type="checkbox"/>	<input type="checkbox"/>	<input type="checkbox"/>					
CARPET	<input type="checkbox"/>	<input checked="" type="checkbox"/>	<input checked="" type="checkbox"/>	<input type="checkbox"/>	<input type="checkbox"/>	<input type="checkbox"/>	<input type="checkbox"/>	<input type="checkbox"/>					
INT. FINISH				B	1	2	3	U					
PLASTER/DW	<input type="checkbox"/>	<input checked="" type="checkbox"/>	<input checked="" type="checkbox"/>	<input type="checkbox"/>	<input type="checkbox"/>	<input type="checkbox"/>	<input type="checkbox"/>	<input type="checkbox"/>					
PANELING	<input type="checkbox"/>	<input checked="" type="checkbox"/>	<input checked="" type="checkbox"/>	<input type="checkbox"/>	<input type="checkbox"/>	<input type="checkbox"/>	<input type="checkbox"/>	<input type="checkbox"/>					
UNFINISHED	<input type="checkbox"/>	<input type="checkbox"/>	<input type="checkbox"/>	<input type="checkbox"/>	<input type="checkbox"/>	<input type="checkbox"/>	<input type="checkbox"/>	<input type="checkbox"/>					
ACCOMMODATIONS													
# OF ROOMS		5	3										
BEDROOMS		1	2										
FIREPLACES													
HEAT & AC				B	1	2	3	U					
NO HEAT	<input type="checkbox"/>	<input type="checkbox"/>	<input type="checkbox"/>	<input type="checkbox"/>	<input type="checkbox"/>	<input type="checkbox"/>	<input type="checkbox"/>	<input type="checkbox"/>					
CTRL HEAT	<input type="checkbox"/>	<input checked="" type="checkbox"/>	<input checked="" type="checkbox"/>	<input type="checkbox"/>	<input type="checkbox"/>	<input type="checkbox"/>	<input type="checkbox"/>	<input type="checkbox"/>					
HW/STEAM	<input type="checkbox"/>	<input type="checkbox"/>	<input type="checkbox"/>	<input type="checkbox"/>	<input type="checkbox"/>	<input type="checkbox"/>	<input type="checkbox"/>	<input type="checkbox"/>					
ELECTRIC	<input type="checkbox"/>	<input type="checkbox"/>	<input type="checkbox"/>	<input type="checkbox"/>	<input type="checkbox"/>	<input type="checkbox"/>	<input type="checkbox"/>	<input type="checkbox"/>					
HEAT PUMP	<input type="checkbox"/>	<input type="checkbox"/>	<input type="checkbox"/>	<input type="checkbox"/>	<input type="checkbox"/>	<input type="checkbox"/>	<input type="checkbox"/>	<input type="checkbox"/>					
FLR/WALL	<input type="checkbox"/>	<input type="checkbox"/>	<input type="checkbox"/>	<input type="checkbox"/>	<input type="checkbox"/>	<input type="checkbox"/>	<input type="checkbox"/>	<input type="checkbox"/>					
STVE/SPCE	<input type="checkbox"/>	<input type="checkbox"/>	<input type="checkbox"/>	<input type="checkbox"/>	<input type="checkbox"/>	<input type="checkbox"/>	<input type="checkbox"/>	<input type="checkbox"/>					
GEO THERMAL	<input type="checkbox"/>	<input type="checkbox"/>	<input type="checkbox"/>	<input type="checkbox"/>	<input type="checkbox"/>	<input type="checkbox"/>	<input type="checkbox"/>	<input type="checkbox"/>					
OUTSIDE	<input type="checkbox"/>	<input type="checkbox"/>	<input type="checkbox"/>	<input type="checkbox"/>	<input type="checkbox"/>	<input type="checkbox"/>	<input type="checkbox"/>	<input type="checkbox"/>					
CTRL A/C	<input type="checkbox"/>	<input type="checkbox"/>	<input type="checkbox"/>	<input type="checkbox"/>	<input type="checkbox"/>	<input type="checkbox"/>	<input type="checkbox"/>	<input type="checkbox"/>					
PLUMBING				BASE <input checked="" type="checkbox"/>									
X FULL BATH													
X HALF BATH		1											
X FIXTURES													
SUBTOTAL							126,080						
MULTI-FAMILY #				0			0						
BUILDING TYPE				100%			0						
BSMT FINISH				0	S.F.		0						
FIREPLACE #				0			0						
HEATING				0	S.F.		0						
AIR COND				0	S.F.		0						
PLUMBING #				2			2,420						
GARAGES & CARPORTS							7,600						
EXTRA FEATURES							13,600						
SUBTOTAL							149,700						
GRADE FACTOR							80 %						
UNADJUSTED VALUE							119,760						
FACTOR							100 %						
OCCUPANCY	ST.HT	SIZE	AREA	GRADE	PRICE	AGE	REMD	CND	UNADJ VAL	PHYS	PHYS VAL	FUNC	TRUE VAL
DWELLING	1+	SK	660	D		1949		A	119,760	50	59,880		44,900
1 Shed	5	10x12	120	C		1990		A		57			0
2 Pool - PP		22x22	484	C		2010		A		21			0
3													
4													
5													
6													
7													
8													
9													
10													
11													
TOTAL												44,900	

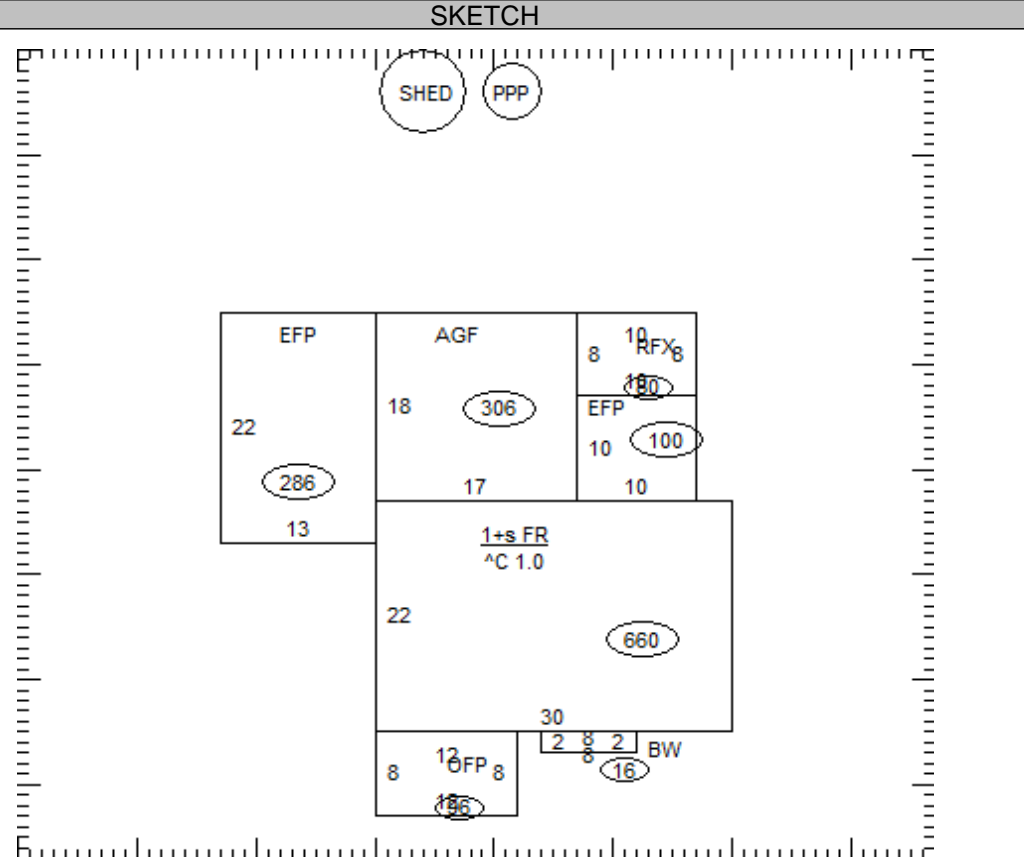

41-017300.0000

COMMENTS

Dwelling has an Economic Factor of 75%