

UNION TWP-MENDON CORP / PARKWAY SD

03-28-203-020

Property Class: 510

Neighborhood

004101-TM20

Map:

Block:

Card: 43

Bk: Pg:

41-016400.0000

**SIEBERT SETH CT**

SIEBERT SETH CT

350 S MAIN ST

MENDON, OH 45862

**LEGAL INFORMATION**

MAURERS 2ND ADD

LOT#: 7

	OWNERSHIP	ADDRESS	CITY	STATE	ZIP	DATE	AMOUNT	DEED:CONV#	JS	VALID
1	SIEBERT SETH CT	350 S MAIN ST	MENDON	OH	45862	05/28/2019	95,000	WDC : 351	<input type="checkbox"/>	<input checked="" type="checkbox"/>
2	PAINTER JAMES L & NANCY A	350 S MAIN ST	MENDON	OH	45862	12/09/2009	0	QCE : X : 0	<input type="checkbox"/>	<input type="checkbox"/>
3	PAINTER JAMES L & NANCY A	350 MAIN ST	MENDON	OH	45862	01/19/1996	25,000	: A : 0	<input type="checkbox"/>	<input checked="" type="checkbox"/>

X:  TTO LISTER: DATE: 09/14/2010 TIME: 12:00:00 AM  LETTER  LETTER REC'D GIS CODE

STREET/ROAD TOPOGRAPHY PU-UTILITIES-PR NEIGHBORHOOD INFLUENCE FACTORS PROPERTY LOCATION

PAVED  LEVEL  WATER  IMPROVING  A. NO ROAD  F. RESTRICT 350 S MAIN ST, MENDON  
 GRAVEL  HIGH  SEWER  STATIC  B. TOPGRHY  G. WOOD LT COMMENT  
 DIRT  LOW  GAS  DECLINING  C. Ex Front  H. VACANCY TY2022:Net Gen=\$1,436.72, Other  
 SIDEWALKS  ROLLING  ELECTRIC  OLD  D. QUANTITY  I. WATER FRONT Assessment=\$2.00  
 CURBS  STANDARD  STANDARD  E. SZ/SHAPE  J. OTHER/CDU DE20 RMV OCC DID NOT RET  
 DE16 ADD CNPY AND CORR HEIGHT OVER HOUSE  
 DE15 RMV EX FIX PER DATA MAILER  
 DE10 TTO; ADD OUTBLDS BACK ONTO THIS PARCEL  
 2 Parcels- 1 map #  
 Parcel 41-016450.0000 part of this parcel, buildings split for taxes only  
 DE22 RMV MMH HK & MMH ADDTN; DESKTOP RVW;

LAND COMPUTATIONS

LAND TYPE	SIZE	M	RATE	C	INF	M	VALUE	C
F:Front	F133 D182	ST160	DP109	ADJ174	C:0.05		22,000	0
TOTAL							22,000	0

VALUATION SUMMARY

VALUE YEAR	2023	2022	2022	2020	2017
REASON FOR CHANGE	RAPP	REMB	REMB	RAPP	RAPP
APPRAISED VALUE	LAND 22,000	18,200	18,200	18,200	13,800
	IMPR 123,300	72,800	72,900	84,700	73,800
	TOTAL 145,300	91,000	91,100	102,900	87,600
ASSESSED VALUE	LAND 7,700	6,370	6,370	6,370	4,830
	IMPR 43,160	25,480	25,520	29,650	25,830
	TOTAL 50,860	31,850	31,890	36,020	30,660

OCCUPANCY	EXTERIOR	FLOOR	AREA	CONST	VALUE
<input checked="" type="checkbox"/> SF <input type="checkbox"/> DU <input type="checkbox"/> TR	<input type="checkbox"/> WOOD	1	1486	FR	201,860
<input type="checkbox"/> CONVERSION	<input type="checkbox"/> STUCCO	.25	290	FR	35,990
<b>BUILDING TYPE</b>	<input checked="" type="checkbox"/> ALM/VYNL				
<input type="checkbox"/> MOBILE HOME	<input type="checkbox"/> CONC BLK				
<input type="checkbox"/> BI/TR LEVEL	<input type="checkbox"/> METAL				
<input type="checkbox"/> MOD/MAN	<input type="checkbox"/> BRICK				
<input type="checkbox"/>	<input type="checkbox"/> STONE				

ROOFING	ROOF TYPE
<input type="checkbox"/> METAL	<input type="checkbox"/> GABLE
<input type="checkbox"/> SLT/TLE	<input type="checkbox"/> HIP
<input checked="" type="checkbox"/> SHINGLES	<input type="checkbox"/> GAMBREL
<input type="checkbox"/> SHAKES	<input type="checkbox"/> MANSARD
<input type="checkbox"/> COMPOSITE	<input type="checkbox"/> FLAT

FLOORS	B	1	2	3	U
CONCRETE	<input checked="" type="checkbox"/>	<input type="checkbox"/>	<input type="checkbox"/>	<input type="checkbox"/>	<input type="checkbox"/>
WOOD	<input type="checkbox"/>	<input checked="" type="checkbox"/>	<input checked="" type="checkbox"/>	<input type="checkbox"/>	<input type="checkbox"/>
TILE/COMPO	<input type="checkbox"/>	<input type="checkbox"/>	<input type="checkbox"/>	<input type="checkbox"/>	<input type="checkbox"/>
CARPET	<input type="checkbox"/>	<input type="checkbox"/>	<input type="checkbox"/>	<input type="checkbox"/>	<input type="checkbox"/>
INT. FINISH	B	1	2	3	U
PLASTER/DW	<input type="checkbox"/>	<input checked="" type="checkbox"/>	<input checked="" type="checkbox"/>	<input type="checkbox"/>	<input type="checkbox"/>
PANELING	<input type="checkbox"/>	<input type="checkbox"/>	<input type="checkbox"/>	<input type="checkbox"/>	<input type="checkbox"/>
UNFINISHED	<input checked="" type="checkbox"/>	<input type="checkbox"/>	<input type="checkbox"/>	<input type="checkbox"/>	<input type="checkbox"/>
ACCOMMODATIONS	# OF ROOMS	6	1		
BEDROOMS		2	1		
FIREPLACES					
HEAT & AC	B	1	2	3	U
NO HEAT	<input type="checkbox"/>	<input type="checkbox"/>	<input type="checkbox"/>	<input type="checkbox"/>	<input type="checkbox"/>
CTRL HEAT	<input type="checkbox"/>	<input checked="" type="checkbox"/>	<input checked="" type="checkbox"/>	<input type="checkbox"/>	<input type="checkbox"/>
HW/STEAM	<input type="checkbox"/>	<input type="checkbox"/>	<input type="checkbox"/>	<input type="checkbox"/>	<input type="checkbox"/>
ELECTRIC	<input type="checkbox"/>	<input type="checkbox"/>	<input type="checkbox"/>	<input type="checkbox"/>	<input type="checkbox"/>
HEAT PUMP	<input type="checkbox"/>	<input type="checkbox"/>	<input type="checkbox"/>	<input type="checkbox"/>	<input type="checkbox"/>
FLR/WALL	<input type="checkbox"/>	<input type="checkbox"/>	<input type="checkbox"/>	<input type="checkbox"/>	<input type="checkbox"/>
STVE/SPCE	<input type="checkbox"/>	<input type="checkbox"/>	<input type="checkbox"/>	<input type="checkbox"/>	<input type="checkbox"/>
GEOHERMAL	<input type="checkbox"/>	<input type="checkbox"/>	<input type="checkbox"/>	<input type="checkbox"/>	<input type="checkbox"/>
OUTSIDE	<input type="checkbox"/>	<input type="checkbox"/>	<input type="checkbox"/>	<input type="checkbox"/>	<input type="checkbox"/>
CTRL A/C	<input type="checkbox"/>	<input type="checkbox"/>	<input type="checkbox"/>	<input type="checkbox"/>	<input type="checkbox"/>
PLUMBING					<input checked="" type="checkbox"/>
X FULL BATH					
X HALF BATH					
X FIXTURES					

BSMT	290	4,150
<b>SUBTOTAL</b>		<b>242,000</b>
MULTI-FAMILY #	0	0
BUILDING TYPE	100%	0
BSMT FINISH	0 S.F.	0
FIREPLACE #	0	0
HEATING	0 S.F.	0
AIR COND	0 S.F.	0
PLUMBING #	0	0
GARAGES & CARPORTS		22,200
EXTRA FEATURES		8,900
<b>SUBTOTAL</b>		<b>273,100</b>
GRADE FACTOR		105 %
<b>UNADJUSTED VALUE</b>		<b>286,760</b>
FACTOR		100 %

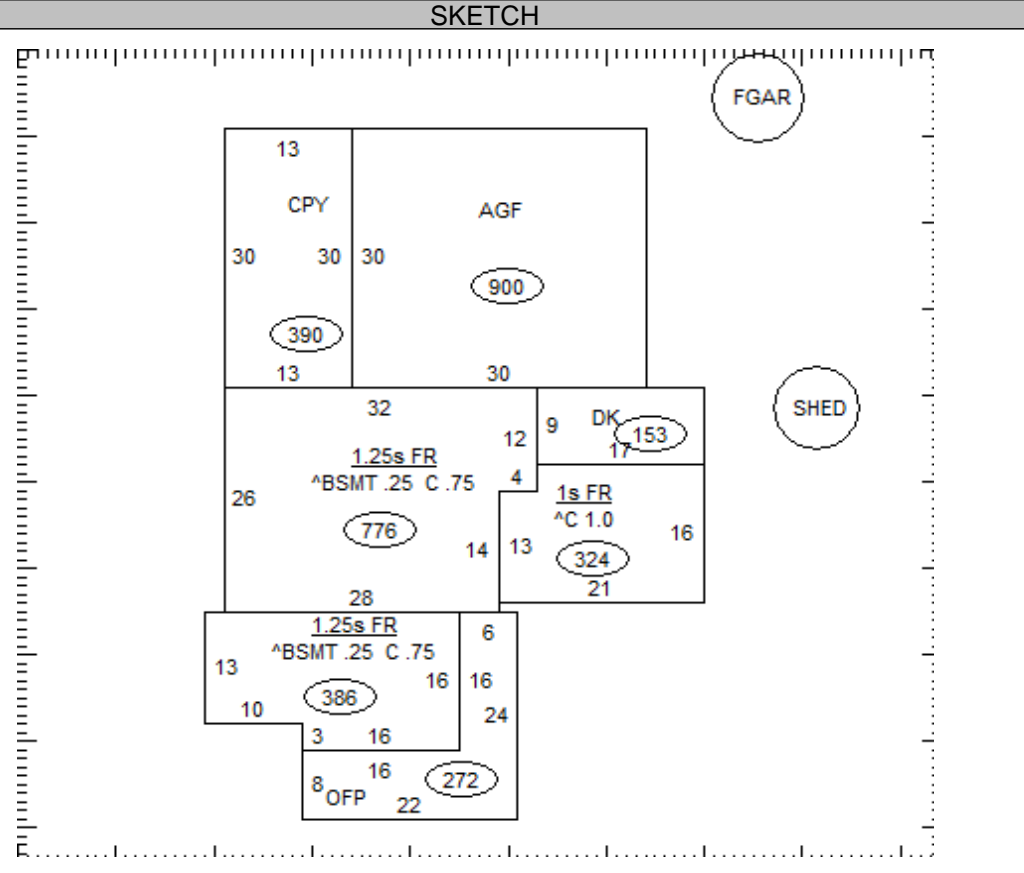

OCCUPANCY	ST.HT	SIZE	AREA	GRADE	PRICE	AGE	REMD	CND	UNADJ VAL	PHYS	PHYS VAL	FUNC	TRUE VAL
DWELLING	1.25	SK	1,776	C+		1910		A	286,760	45	157,720		118,300
1 Gar - Frame		20x20	400	C	23.70	1996		A	9,480	47	5,020		5,000
2 Shed		10x12	120	C		2020		A		3			0
3													
4													
5													
6													
7													
8													
9													
10													
11													

41-016400.0000

TOTAL 123,300

**COMMENTS**

MH/OAKBRIDGE #54-04210 12X60 BARBARA ARMSTRONG  
 Dwelling has an Economic Factor of 75%