

UNION TWP / PARKWAY SD

03-24-400-011



40-037600.0200

BALL JUSTIN L & APRIL L

BALL JUSTIN L & APRIL L

8970 DEEP CUT RD

SPENCERVILLE, OH 45887

Created in 2020 From 40-037600.0100 due to Split

LEGAL INFORMATION

PT NE SE

RTS: 003-04-24

Acres:5.0000

	OWNERSHIP	ADDRESS	CITY	STATE	ZIP	DATE	AMOUNT	DEED:CONV#	JS	VALID
1	BALL JUSTIN L & APRIL L	8970 DEEP CUT RD	SPENCERVILLE	OH	45887	02/03/2020	225,000	WDC : 65	<input type="checkbox"/>	<input checked="" type="checkbox"/>
2							0	0	<input type="checkbox"/>	<input type="checkbox"/>
3							0	0	<input type="checkbox"/>	<input type="checkbox"/>

X: TTO LISTER: DATE: TIME: LETTER LETTER REC'D GIS CODE

STREET/ROAD	TOPOGRAPHY	PU-UTILITIES-PR	NEIGHBORHOOD	INFLUENCE FACTORS	PROPERTY LOCATION	
<input type="checkbox"/> PAVED <input type="checkbox"/> GRAVEL <input type="checkbox"/> DIRT <input type="checkbox"/> SIDEWALKS <input type="checkbox"/> CURBS	<input type="checkbox"/> LEVEL <input type="checkbox"/> HIGH <input type="checkbox"/> LOW <input type="checkbox"/> ROLLING <input type="checkbox"/> STANDARD	<input type="checkbox"/> WATER <input type="checkbox"/> SEWER <input type="checkbox"/> GAS <input type="checkbox"/> ELECTRIC <input type="checkbox"/> STANDARD	<input type="checkbox"/> IMPROVING <input type="checkbox"/> STATIC <input type="checkbox"/> DECLINING <input type="checkbox"/> OLD <input type="checkbox"/> STANDARD	<input type="checkbox"/> A. NO ROAD <input type="checkbox"/> B. TOPGRHY <input type="checkbox"/> C. Ex Front <input type="checkbox"/> D. QUANTITY <input type="checkbox"/> E. SZ/SHAPE	<input type="checkbox"/> F. RESTRICT <input type="checkbox"/> G. WOOD LT <input type="checkbox"/> H. VACANCY <input type="checkbox"/> I. WATER FRONT <input type="checkbox"/> J. OTHER/CDU	8970 DEEP CUT RD COMMENT TY2022:Net Gen=\$2,197.74, Other Assessment=\$2.00

LAND COMPUTATIONS							
LAND TYPE	SIZE	M	RATE	C	INF	M	VALUE C
HS:Home Site	AC:1		19710				19,700 0
SM:Small Acreage	AC:4		7900				31,600 0
Total Acres: 5.0000						TOTAL	51,300 0

VALUATION SUMMARY				
VALUE YEAR	2023	2020	2020	
REASON FOR CHANGE	RAPP	RAPP	MISC	
APPRAISED	LAND			
VALUE	IMPR			
	TOTAL			
ASSESSED	LAND			
VALUE	IMPR			
	TOTAL			
	51,300	48,000	42,100	
	139,900	101,500	83,500	
	191,200	149,500	125,600	
	17,960	16,800	14,740	
	48,970	35,530	29,230	
	66,930	52,330	43,970	

OCCUPANCY		EXTERIOR		FLOOR	AREA	CONST	VALUE
<input checked="" type="checkbox"/> SF	<input type="checkbox"/> DU	<input type="checkbox"/> TR	<input type="checkbox"/> WOOD	1	1836	FR	224,690
<input type="checkbox"/> CONVERSION			<input type="checkbox"/> STUCCO	.25	126	FR	14,060
BUILDING TYPE			<input checked="" type="checkbox"/> ALM/VYNL	+	0	FR	4,580
<input type="checkbox"/> MOBILE HOME			<input type="checkbox"/> CONC BLK				
<input type="checkbox"/> BI/TR LEVEL			<input type="checkbox"/> METAL				
<input type="checkbox"/> MOD/MAN			<input type="checkbox"/> BRICK				
<input type="checkbox"/>			<input type="checkbox"/> STONE				
ROOFING		ROOF TYPE					
<input type="checkbox"/> METAL			<input checked="" type="checkbox"/> GABLE				
<input type="checkbox"/> SLT/TLE			<input type="checkbox"/> HIP				
<input checked="" type="checkbox"/> SHINGLES			<input type="checkbox"/> GAMBREL				
<input type="checkbox"/> SHAKES			<input type="checkbox"/> MANSARD				
<input type="checkbox"/> COMPOSITE			<input type="checkbox"/> FLAT				
FLOORS		B	1	2	3	U	
CONCRETE	<input type="checkbox"/>	<input type="checkbox"/>	<input type="checkbox"/>	<input type="checkbox"/>	<input type="checkbox"/>	<input type="checkbox"/>	
WOOD	<input type="checkbox"/>	<input checked="" type="checkbox"/>	<input type="checkbox"/>	<input checked="" type="checkbox"/>	<input type="checkbox"/>	<input type="checkbox"/>	
TILE/COMPO	<input type="checkbox"/>	<input checked="" type="checkbox"/>	<input type="checkbox"/>	<input type="checkbox"/>	<input type="checkbox"/>	<input type="checkbox"/>	
CARPET	<input type="checkbox"/>	<input type="checkbox"/>	<input type="checkbox"/>	<input type="checkbox"/>	<input type="checkbox"/>	<input type="checkbox"/>	
INT. FINISH		B	1	2	3	U	
PLASTER/DW	<input type="checkbox"/>	<input checked="" type="checkbox"/>	<input type="checkbox"/>	<input checked="" type="checkbox"/>	<input type="checkbox"/>	<input type="checkbox"/>	
PANELING	<input type="checkbox"/>	<input type="checkbox"/>	<input type="checkbox"/>	<input type="checkbox"/>	<input type="checkbox"/>	<input type="checkbox"/>	
UNFINISHED	<input checked="" type="checkbox"/>	<input type="checkbox"/>	<input type="checkbox"/>	<input type="checkbox"/>	<input type="checkbox"/>	<input type="checkbox"/>	
ACCOMMODATIONS							
# OF ROOMS	1	6		2			
BEDROOMS		2		2			
FIREPLACES							
HEAT & AC		B	1	2	3	U	
NO HEAT	<input type="checkbox"/>	<input type="checkbox"/>	<input type="checkbox"/>	<input type="checkbox"/>	<input type="checkbox"/>	<input type="checkbox"/>	
CTRL HEAT	<input type="checkbox"/>	<input checked="" type="checkbox"/>	<input type="checkbox"/>	<input checked="" type="checkbox"/>	<input type="checkbox"/>	<input type="checkbox"/>	
HW/STEAM	<input type="checkbox"/>	<input type="checkbox"/>	<input type="checkbox"/>	<input type="checkbox"/>	<input type="checkbox"/>	<input type="checkbox"/>	
ELECTRIC	<input type="checkbox"/>	<input type="checkbox"/>	<input type="checkbox"/>	<input type="checkbox"/>	<input type="checkbox"/>	<input type="checkbox"/>	
HEAT PUMP	<input type="checkbox"/>	<input type="checkbox"/>	<input type="checkbox"/>	<input type="checkbox"/>	<input type="checkbox"/>	<input type="checkbox"/>	
FLR/WALL	<input type="checkbox"/>	<input type="checkbox"/>	<input type="checkbox"/>	<input type="checkbox"/>	<input type="checkbox"/>	<input type="checkbox"/>	
STVE/SPCE	<input type="checkbox"/>	<input type="checkbox"/>	<input type="checkbox"/>	<input type="checkbox"/>	<input type="checkbox"/>	<input type="checkbox"/>	
GEOTHERMAL	<input type="checkbox"/>	<input type="checkbox"/>	<input type="checkbox"/>	<input type="checkbox"/>	<input type="checkbox"/>	<input type="checkbox"/>	
OUTSIDE	<input type="checkbox"/>	<input type="checkbox"/>	<input type="checkbox"/>	<input type="checkbox"/>	<input type="checkbox"/>	<input type="checkbox"/>	
CTRL A/C	<input type="checkbox"/>	<input checked="" type="checkbox"/>	<input type="checkbox"/>	<input type="checkbox"/>	<input type="checkbox"/>	<input type="checkbox"/>	
PLUMBING		BASE					
X FULL BATH	<input type="checkbox"/>	<input type="checkbox"/>	<input type="checkbox"/>	<input type="checkbox"/>	<input type="checkbox"/>	<input type="checkbox"/>	
X HALF BATH	<input type="checkbox"/>	<input type="checkbox"/>	<input type="checkbox"/>	<input type="checkbox"/>	<input type="checkbox"/>	<input type="checkbox"/>	
X FIXTURES	<input type="checkbox"/>	<input type="checkbox"/>	<input type="checkbox"/>	<input type="checkbox"/>	<input type="checkbox"/>	<input type="checkbox"/>	
BSMT		337					4,820
SUBTOTAL							248,150
MULTI-FAMILY #		0					0
BUILDING TYPE		100%					0
BSMT FINISH		0 S.F.					0
FIREPLACE #		0					0
HEATING		0 S.F.					0
AIR COND		1,836 S.F.					3,030
PLUMBING #		0					0
GARAGES & CARPORTS							14,200
EXTRA FEATURES							7,400
SUBTOTAL							272,780
GRADE FACTOR							100 %
UNADJUSTED VALUE							272,780
FACTOR							100 %

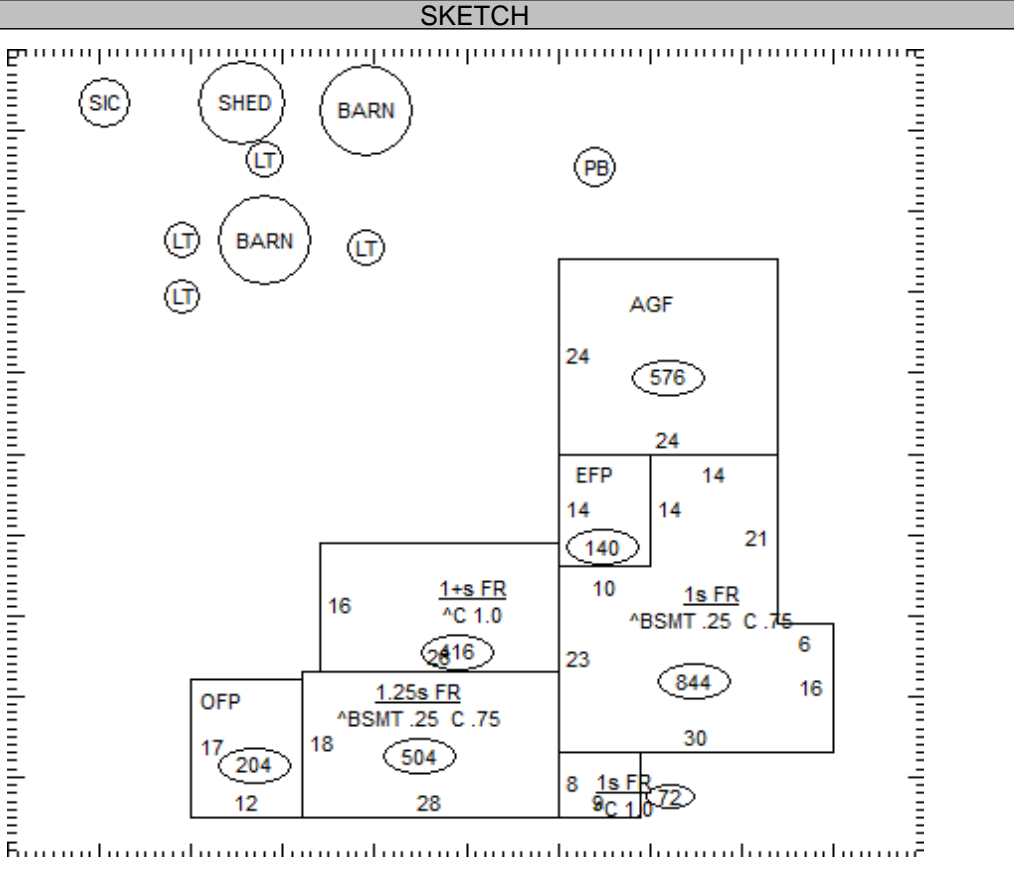

OCCUPANCY	ST.HT	SIZE	AREA	GRADE	PRICE	AGE	REMD	CND	UNADJ VAL	PHYS	PHYS VAL	FUNC	TRUE VAL
DWELLING	1.25	SK	1,962	C		1940		A	272,780	45	150,030		127,500
1 Barn		42x72	3,024	C	12.00	1972		A	36,290	85	5,440	DFLT50	2,700
2 Lean - To		6x39	234	C	4.80	1940		A	1,120	95	60		100
3 Lean - To	10	26x88	2,288	C	4.80	1940		A	10,980	95	550	DFLT10	500
4 Lean - To	10	26x57	1,482	C	4.80	1940		A	7,110	95	360	DFLT10	300
5 Barn	10	30x42	1,260	D	9.60	1940		A	12,100	95	610	DFLT50	300
6 Shed	12	42x70	2,940	C	7.10	1965		A	20,870	85	3,130	DFLT10	2,800
7 Lean - To	10	20x57	1,140	C	4.80	1965		A	5,470	85	820	DFLT10	700
8 Pole Bldg	12	42x56	2,352	C	11.87	1965		A	27,920	85	4,190		4,200
9 Silo - Concrete	48	48x16	768	C	750.00	1965		A	750		750		800
10													
11													

40-037600.0200

TOTAL 139,900

COMMENTS

Dwelling has an Economic Factor of 85%