

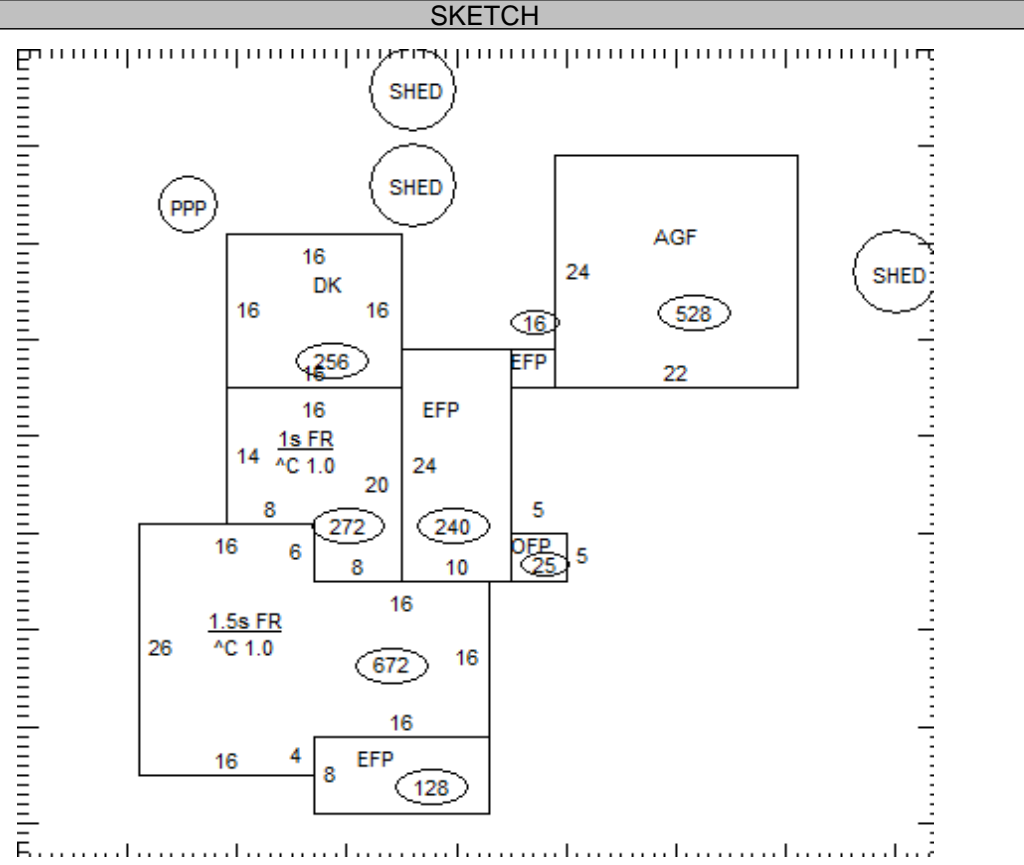

OCCUPANCY		EXTERIOR		FLOOR	AREA	CONST	VALUE						
<input checked="" type="checkbox"/> SF	<input type="checkbox"/> DU	<input type="checkbox"/> TR	<input type="checkbox"/> WOOD	1	944	FR	154,690						
<input type="checkbox"/> CONVERSION			<input type="checkbox"/> STUCCO	.5	336	FR	34,140						
BUILDING TYPE		<input checked="" type="checkbox"/> ALM/VYNL											
<input type="checkbox"/> MOBILE HOME			<input type="checkbox"/> CONC BLK										
<input type="checkbox"/> BI/TR LEVEL			<input type="checkbox"/> METAL										
<input type="checkbox"/> MOD/MAN			<input type="checkbox"/> BRICK										
<input type="checkbox"/>			<input type="checkbox"/> STONE										
ROOFING		ROOF TYPE											
<input type="checkbox"/> METAL			<input checked="" type="checkbox"/> GABLE										
<input type="checkbox"/> SLT/TLE			<input type="checkbox"/> HIP										
<input checked="" type="checkbox"/> SHINGLES			<input type="checkbox"/> GAMBREL										
<input type="checkbox"/> SHAKES			<input type="checkbox"/> MANSARD										
<input type="checkbox"/> COMPOSITE			<input type="checkbox"/> FLAT										
FLOORS		B	1	2	3	U							
CONCRETE	<input type="checkbox"/>	<input type="checkbox"/>	<input type="checkbox"/>	<input type="checkbox"/>	<input type="checkbox"/>	<input type="checkbox"/>							
WOOD	<input type="checkbox"/>	<input checked="" type="checkbox"/>	<input checked="" type="checkbox"/>	<input type="checkbox"/>	<input type="checkbox"/>	<input type="checkbox"/>							
TILE/COMPO	<input type="checkbox"/>	<input type="checkbox"/>	<input type="checkbox"/>	<input type="checkbox"/>	<input type="checkbox"/>	<input type="checkbox"/>							
CARPET	<input type="checkbox"/>	<input checked="" type="checkbox"/>	<input type="checkbox"/>	<input type="checkbox"/>	<input type="checkbox"/>	<input type="checkbox"/>							
INT. FINISH		B	1	2	3	U							
PLASTER/DW	<input type="checkbox"/>	<input type="checkbox"/>	<input type="checkbox"/>	<input type="checkbox"/>	<input type="checkbox"/>	<input type="checkbox"/>							
PANELING	<input type="checkbox"/>	<input type="checkbox"/>	<input type="checkbox"/>	<input type="checkbox"/>	<input type="checkbox"/>	<input type="checkbox"/>							
UNFINISHED	<input type="checkbox"/>	<input type="checkbox"/>	<input type="checkbox"/>	<input type="checkbox"/>	<input type="checkbox"/>	<input type="checkbox"/>							
ACCOMMODATIONS													
# OF ROOMS		5	2										
BEDROOMS		1	1										
FIREPLACES													
HEAT & AC		B	1	2	3	U							
NO HEAT	<input type="checkbox"/>	<input type="checkbox"/>	<input type="checkbox"/>	<input type="checkbox"/>	<input type="checkbox"/>	<input type="checkbox"/>							
CTRL HEAT	<input type="checkbox"/>	<input checked="" type="checkbox"/>	<input checked="" type="checkbox"/>	<input type="checkbox"/>	<input type="checkbox"/>	<input type="checkbox"/>							
HW/STEAM	<input type="checkbox"/>	<input checked="" type="checkbox"/>	<input checked="" type="checkbox"/>	<input type="checkbox"/>	<input type="checkbox"/>	<input type="checkbox"/>							
ELECTRIC	<input type="checkbox"/>	<input type="checkbox"/>	<input type="checkbox"/>	<input type="checkbox"/>	<input type="checkbox"/>	<input type="checkbox"/>							
HEAT PUMP	<input type="checkbox"/>	<input type="checkbox"/>	<input type="checkbox"/>	<input type="checkbox"/>	<input type="checkbox"/>	<input type="checkbox"/>							
FLR/WALL	<input type="checkbox"/>	<input type="checkbox"/>	<input type="checkbox"/>	<input type="checkbox"/>	<input type="checkbox"/>	<input type="checkbox"/>							
STVE/SPCE	<input type="checkbox"/>	<input type="checkbox"/>	<input type="checkbox"/>	<input type="checkbox"/>	<input type="checkbox"/>	<input type="checkbox"/>							
GEO THERMAL	<input type="checkbox"/>	<input type="checkbox"/>	<input type="checkbox"/>	<input type="checkbox"/>	<input type="checkbox"/>	<input type="checkbox"/>							
OUTSIDE	<input type="checkbox"/>	<input type="checkbox"/>	<input type="checkbox"/>	<input type="checkbox"/>	<input type="checkbox"/>	<input type="checkbox"/>							
CTRL A/C	<input type="checkbox"/>	<input type="checkbox"/>	<input type="checkbox"/>	<input type="checkbox"/>	<input type="checkbox"/>	<input type="checkbox"/>							
PLUMBING		BASE		<input checked="" type="checkbox"/>									
X FULL BATH													
X HALF BATH		1											
X FIXTURES													
SUBTOTAL							188,830						
MULTI-FAMILY #	0						0						
BUILDING TYPE	100%						0						
BSMT FINISH	0 S.F.						0						
FIREPLACE #	0						0						
HEATING	0 S.F.						0						
AIR COND	0 S.F.						0						
PLUMBING #	2						2,420						
GARAGES & CARPORTS							13,100						
EXTRA FEATURES							14,200						
SUBTOTAL							218,550						
GRADE FACTOR							100 %						
UNADJUSTED VALUE							218,550						
FACTOR							100 %						
OCCUPANCY	ST.HT	SIZE	AREA	GRADE	PRICE	AGE	REMD	CND	UNADJ VAL	PHYS	PHYS VAL	FUNC	TRUE VAL
DWELLING	1.5	SK	1,280	C		1940		A	218,550	45	120,200		102,200
1 Pool - PP	PP	16x16	256	C		2005		A		31			0
2 Shed	PP	10x12	120	C		2010		A		21		DFLT7	0
3 Shed	PP	8x8	64	C		1970		A		85			0
4 Shed		10x12	120	C		2000		A		37			0
5													
6													
7													
8													
9													
10													
11													



40-012000.0000

TOTAL 102,200

COMMENTS

Dwelling has an Economic Factor of 85% (Rollback Basis=\$121,900)

40-012000.0000

SCHMERSAL GUY & STACY

SCHMERSAL GUY & STACY

12150 TOMLINSON RD

ROCKFORD, OH 45882

LEGAL INFORMATION

SW COR NW SW

RTS: 003-04-08

Acres:2.3100

	OWNERSHIP	ADDRESS	CITY	STATE	ZIP	DATE	AMOUNT	DEED:CONV#	JS	VALID
1	EDGECOMB JACK L	973 BRICE AVE	LIMA	OH	45805	04/25/2007	0	QCE : X : 0	<input type="checkbox"/>	<input type="checkbox"/>
2	EDGECOMB JACK L &	12150 TOMLINSON RD	ROCKFORD	OH	45882	04/27/1988	27,000	: A : 0	<input type="checkbox"/>	<input checked="" type="checkbox"/>
3							0	0	<input type="checkbox"/>	<input type="checkbox"/>

X: Signature  TTO LISTER: AE DATE: 07/20/2004 TIME: 11:36:31 AM  LETTER  LETTER REC'D GIS CODE

STREET/ROAD	TOPOGRAPHY	PU-UTILITIES-PR	NEIGHBORHOOD	INFLUENCE FACTORS	PROPERTY LOCATION	
<input checked="" type="checkbox"/> PAVED <input type="checkbox"/> GRAVEL <input type="checkbox"/> DIRT <input type="checkbox"/> SIDEWALKS <input type="checkbox"/> CURBS	<input checked="" type="checkbox"/> LEVEL <input type="checkbox"/> HIGH <input type="checkbox"/> LOW <input type="checkbox"/> ROLLING <input type="checkbox"/> STANDARD	<input type="checkbox"/> WATER <input type="checkbox"/> SEWER <input type="checkbox"/> GAS <input checked="" type="checkbox"/> ELECTRIC <input type="checkbox"/> STANDARD	<input checked="" type="checkbox"/> IMPROVING <input checked="" type="checkbox"/> STATIC <input type="checkbox"/> DECLINING <input type="checkbox"/> OLD <input type="checkbox"/> STANDARD	<input type="checkbox"/> A. NO ROAD <input type="checkbox"/> B. TOPGRHY <input type="checkbox"/> C. Ex Front <input type="checkbox"/> D. QUANTITY <input type="checkbox"/> E. SZ/SHAPE	<input type="checkbox"/> F. RESTRICT <input type="checkbox"/> G. WOOD LT <input type="checkbox"/> H. VACANCY <input type="checkbox"/> I. WATER FRONT <input type="checkbox"/> J. OTHER/CDU	12150 TOMLINSON RD, ROCKFORD COMMENT

LAND COMPUTATIONS							
LAND TYPE	SIZE	M	RATE	C	INF	M	VALUE C
Total Acres: 2.3100					TOTAL	30,600	0

VALUATION SUMMARY

VALUE YEAR							
REASON FOR CHANGE							
APPRaised	<u>LAND</u>						
VALUE	<u>IMPR</u>						
	<u>TOTAL</u>						
ASSESSED	<u>LAND</u>						
VALUE	<u>IMPR</u>						
	<u>TOTAL</u>						

