

UNION TWP / PARKWAY SD

03-02-100-003

40-001600.0100

LEGAL INFORMATION

N PT E 1/2 NE

RTS: 003-04-02

Acres:1.8140

HENDERSON GARRETT J
HENDERSON GARRETT J
8186 MERCER VAN WERT CO LINE RD
MENDON, OH 45862

	OWNERSHIP	ADDRESS	CITY	STATE	ZIP	DATE	AMOUNT	DEED:CONV#	JS	VALID
1	HENDERSON GARRETT J	8186 MERCER VAN WERT	MENDON	OH	45862	08/12/2021	160,000	WDC : 654	<input type="checkbox"/>	<input checked="" type="checkbox"/>
2	POLING JENNIFER	8186 MERCER VAN WERT	VENEDOCIA	OH	45894	06/13/2019	0	QCE : X : 0	<input type="checkbox"/>	<input type="checkbox"/>
3	POLING BRANDAN DAVID &	8186 MER VAN WERT CO	ELGIN	OH	45838	05/02/1995	18,000	: A : 0	<input type="checkbox"/>	<input type="checkbox"/>

X: TTO LISTER: cg DATE: 05/24/2006 TIME: 12:00:00 AM LETTER LETTER REC'D GIS CODE Minor Sub

STREET/ROAD	TOPOGRAPHY	PU-UTILITIES-PR	NEIGHBORHOOD	INFLUENCE FACTORS	PROPERTY LOCATION	
<input checked="" type="checkbox"/> PAVED <input type="checkbox"/> GRAVEL <input type="checkbox"/> DIRT <input type="checkbox"/> SIDEWALKS <input type="checkbox"/> CURBS	<input checked="" type="checkbox"/> LEVEL <input type="checkbox"/> HIGH <input type="checkbox"/> LOW <input type="checkbox"/> ROLLING <input type="checkbox"/> STANDARD	<input type="checkbox"/> WATER <input type="checkbox"/> SEWER <input type="checkbox"/> GAS <input type="checkbox"/> ELECTRIC <input checked="" type="checkbox"/> STANDARD	<input type="checkbox"/> IMPROVING <input checked="" type="checkbox"/> STATIC <input type="checkbox"/> DECLINING <input type="checkbox"/> OLD <input type="checkbox"/> STANDARD	<input type="checkbox"/> A. NO ROAD <input type="checkbox"/> B. TOPGRHY <input type="checkbox"/> C. Ex Front <input type="checkbox"/> D. QUANTITY <input type="checkbox"/> E. SZ/SHAPE	<input type="checkbox"/> F. RESTRICT <input type="checkbox"/> G. WOOD LT <input type="checkbox"/> H. VACANCY <input type="checkbox"/> I. WATER FRONT <input type="checkbox"/> J. OTHER/CDU	8186 MERCER VAN WERT CO LINE RD, VENEDOCIA COMMENT TY2022:Net Gen=\$1,739.12, Other Assessment=\$27.16 DE17 FIELD REVW CHGS: COR OUTBLDGS

LAND COMPUTATIONS

LAND TYPE	SIZE	M	RATE	C	INF	M	VALUE	C
HS:Home Site	AC:1	19710				19,700	0	
SM:Small Acreage	AC:0.814	8500				6,900	0	
Total Acres: 1.8140					TOTAL	26,600	0	

VALUATION SUMMARY

VALUE YEAR	2023	2020	2017	2017				
REASON FOR CHANGE	RAPP	RAPP	RAPP	MISC				
APPRAISED	26,600	25,300	22,200	19,000				
VALUE	132,600	93,000	77,000	68,900				
	<u>TOTAL</u>	159,200	118,300	99,200	87,900			
ASSESSED	9,310	8,860	7,770	6,650				
VALUE	46,410	32,550	26,950	24,120				
	<u>TOTAL</u>	55,720	41,410	34,720	30,770			

<input checked="" type="checkbox"/> SF <input type="checkbox"/> DU <input type="checkbox"/> TR	<input checked="" type="checkbox"/> WOOD	FLOOR	AREA	CONST	VALUE
<input type="checkbox"/> CONVERSION	<input type="checkbox"/> STUCCO	1	1400	FR	193,380
BUILDING TYPE	<input type="checkbox"/> ALM/VYNL	2ND	768	FR	50,920
<input type="checkbox"/> MOBILE HOME	<input type="checkbox"/> CONC BLK				
<input type="checkbox"/> BI/TR LEVEL	<input type="checkbox"/> METAL				
<input type="checkbox"/> MOD/MAN	<input type="checkbox"/> BRICK				
<input type="checkbox"/> _____	<input type="checkbox"/> STONE				

ROOFING	ROOF TYPE				
<input type="checkbox"/> METAL	<input checked="" type="checkbox"/> GABLE				
<input checked="" type="checkbox"/> SLT/TLE	<input type="checkbox"/> HIP				
<input type="checkbox"/> SHINGLES	<input type="checkbox"/> GAMBREL				
<input type="checkbox"/> SHAKES	<input type="checkbox"/> MANSARD				
<input type="checkbox"/> COMPOSITE	<input type="checkbox"/> FLAT				

FLOORS	B	1	2	3	U		
CONCRETE	<input checked="" type="checkbox"/>	<input type="checkbox"/>	<input type="checkbox"/>	<input type="checkbox"/>	<input type="checkbox"/>		
WOOD	<input type="checkbox"/>	<input checked="" type="checkbox"/>	<input checked="" type="checkbox"/>	<input type="checkbox"/>	<input type="checkbox"/>		
TILE/COMPO	<input type="checkbox"/>	<input type="checkbox"/>	<input type="checkbox"/>	<input type="checkbox"/>	<input type="checkbox"/>		
CARPET	<input type="checkbox"/>	<input checked="" type="checkbox"/>	<input type="checkbox"/>	<input type="checkbox"/>	<input type="checkbox"/>		
INT. FINISH	B	1	2	3	U		
PLASTER/DW	<input type="checkbox"/>	<input checked="" type="checkbox"/>	<input checked="" type="checkbox"/>	<input type="checkbox"/>	<input type="checkbox"/>		
PANELING	<input type="checkbox"/>	<input type="checkbox"/>	<input type="checkbox"/>	<input type="checkbox"/>	<input type="checkbox"/>		
UNFINISHED	<input checked="" type="checkbox"/>	<input type="checkbox"/>	<input type="checkbox"/>	<input type="checkbox"/>	<input type="checkbox"/>		
ACCOMMODATIONS							
# OF ROOMS		4	3				
BEDROOMS		1	3				
FIREPLACES							
HEAT & AC	B	1	2	3	U		
NO HEAT	<input type="checkbox"/>	<input type="checkbox"/>	<input checked="" type="checkbox"/>	<input type="checkbox"/>	<input type="checkbox"/>		
CTRL HEAT	<input type="checkbox"/>	<input checked="" type="checkbox"/>	<input type="checkbox"/>	<input type="checkbox"/>	<input type="checkbox"/>		
HW/STEAM	<input type="checkbox"/>	<input type="checkbox"/>	<input type="checkbox"/>	<input type="checkbox"/>	<input type="checkbox"/>		
ELECTRIC	<input type="checkbox"/>	<input type="checkbox"/>	<input type="checkbox"/>	<input type="checkbox"/>	<input type="checkbox"/>		
HEAT PUMP	<input type="checkbox"/>	<input type="checkbox"/>	<input type="checkbox"/>	<input type="checkbox"/>	<input type="checkbox"/>		
FLR/WALL	<input type="checkbox"/>	<input checked="" type="checkbox"/>	<input type="checkbox"/>	<input type="checkbox"/>	<input type="checkbox"/>		
STVE/SPCE	<input type="checkbox"/>	<input type="checkbox"/>	<input type="checkbox"/>	<input type="checkbox"/>	<input type="checkbox"/>		
GEOHERMAL	<input type="checkbox"/>	<input type="checkbox"/>	<input type="checkbox"/>	<input type="checkbox"/>	<input type="checkbox"/>		
OUTSIDE	<input type="checkbox"/>	<input type="checkbox"/>	<input type="checkbox"/>	<input type="checkbox"/>	<input type="checkbox"/>		
CTRL A/C	<input type="checkbox"/>	<input type="checkbox"/>	<input type="checkbox"/>	<input type="checkbox"/>	<input type="checkbox"/>		
PLUMBING						BASE	<input checked="" type="checkbox"/>
X FULL BATH							
X HALF BATH							
X FIXTURES							

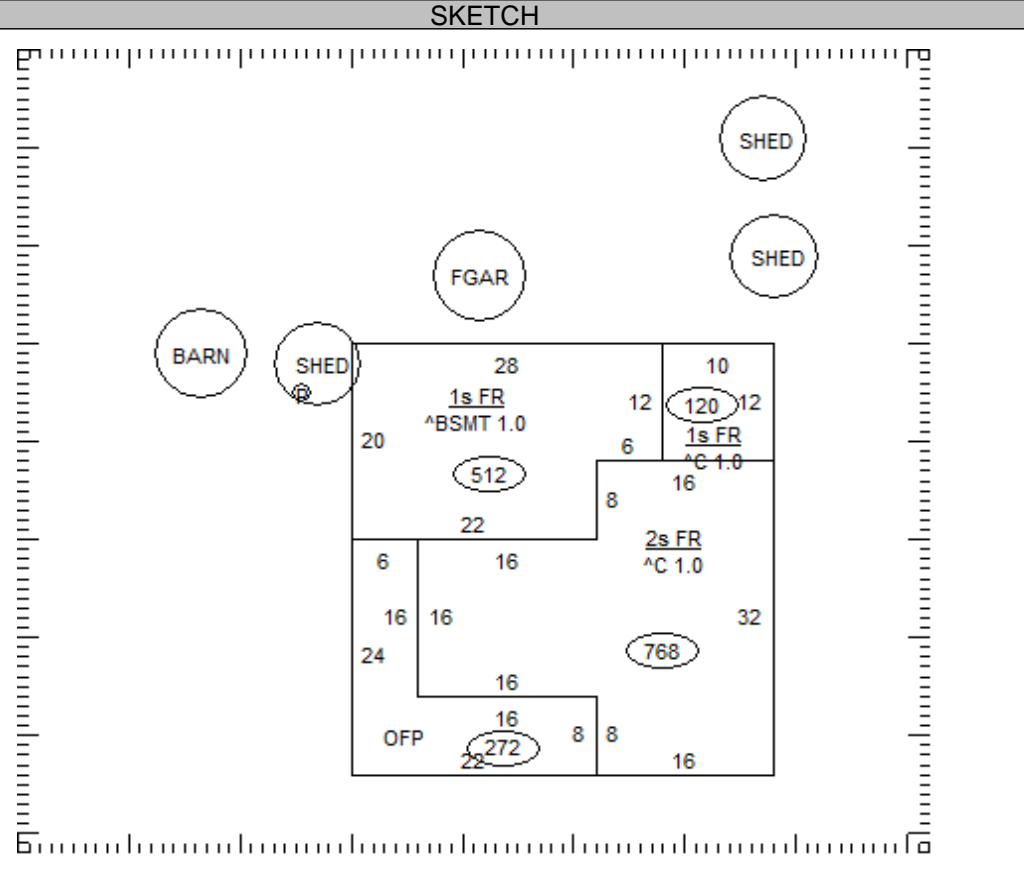

OCCUPANCY	ST.HT	SIZE	AREA	GRADE	PRICE	AGE	REMD	CND	UNADJ VAL	PHYS	PHYS VAL	FUNC	TRUE VAL
DWELLING	2	SK	2,168	C		1902		A	253,100	45	139,210		118,300
1 Barn	14	40x60	2,400	D	9.60	1902		A	23,040	95	1,150	DFLT50	600
2 Shed	10	8x8	64	C		1902		F		95			0
3 Shed	SV*	20x46	920	C		1980	2008	A	200	77			200
4 Shed	PP	10x10	100	C		1980		A		77			0
5 Gar - Frame		26x30	780	C	23.70	2006		A	18,490	29	13,130		13,100
6 Patio		14x14	196	C	4.05	1995		A	790	47	420		400
7													
8													
9													
10													
11													

40-001600.0100	* Value Override Item	TOTAL	132,600
----------------	-----------------------	-------	---------

COMMENTS	
Dwelling has an Economic Factor of 85%	