



39-017600.0000

RECOVERY TWP-FT RECOVERY CO
 FT RECOVERY SD
 10-20-252-023

LEGAL INFORMATION

MCDANIELS ADDITION LOTS 22 & 23
 ALSO 1/2 VACATED ST.
 TO EAST

LENNCO PROPERTIES LLC
 LENNCO PROPERTIES LLC
 409 E BROADWAY ST APT A PO BOX 366
 FORT RECOVERY, OH 45846

Neighborhood CVIL39	
Map:	
Block:	
Card:	
Bk:	Pg:

COMMENT
 TY2022:Net Gen=\$2,917.60, Other Assessment=\$3.04
 DE17 DESKTOP RVW CHG: ADJ PRICING
 DE23 CHG GRD & BDLG CODE; DESKTOP RVW

Sales Data						Date
Date	Amount	Deed:Conv#	Use	Valid	Lister:	03/09/23
04/09/2021	400,000		2:WDC : 256	401	<input checked="" type="checkbox"/>	Pricer:
02/20/2013	0		6:QCE : X : 0	401	<input type="checkbox"/>	Reviewer:
12/05/2012	325,000		3:WDC : 773	401	<input type="checkbox"/>	Final:
07/21/1997	58,000		: A-M : 0	401	<input type="checkbox"/>	Call Back:
					<input type="checkbox"/>	Visit:

VALUATION SUMMARY				
VALUE YEAR	2023	2020	2017	2017
REASON FOR CHANGE	RAPP	RAPP	RAPP	MISC
ESTIMATED	23,270	15,510	15,510	15,510
MARKET VALUE	187,330	158,090	158,090	143,490
	<u>TOTAL</u>	210,600	173,600	159,000
ASSESSED	8,140	5,430	5,430	5,430
VALUE	65,570	55,330	55,330	50,220
	<u>TOTAL</u>	73,710	60,760	55,650

LAND TYPE	SIZE	M	RATE	C	INF	M	VALUE	C
F:Front	F165 D132		ST150 DP94 ADJ141				23,270	0
Totals:							23,270	0

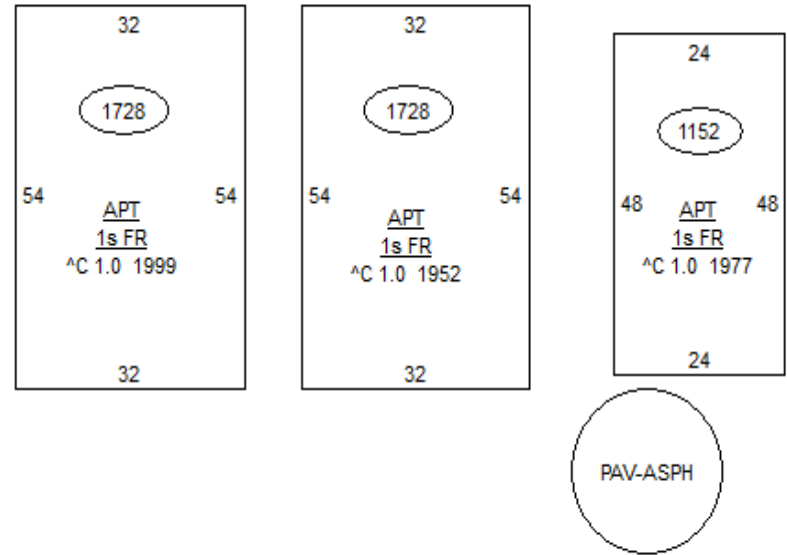

STREET/ROAD	TOPOGRAPHY	PU-UTILITIES-PR	ZONING
<input type="checkbox"/> PAVED	<input type="checkbox"/> LEVEL	<input checked="" type="checkbox"/> WATER	<input type="checkbox"/> AG-RES
<input type="checkbox"/> GRAVEL	<input type="checkbox"/> HIGH	<input checked="" type="checkbox"/> SEWER	<input checked="" type="checkbox"/> COMMERCIAL
<input type="checkbox"/> DIRT	<input type="checkbox"/> LOW	<input type="checkbox"/> GAS	<input type="checkbox"/> INDUSTRIAL
<input type="checkbox"/> SIDEWALKS	<input type="checkbox"/> ROLLING	<input checked="" type="checkbox"/> ELECTRIC	
<input type="checkbox"/> CURBS	<input type="checkbox"/> STANDARD	<input type="checkbox"/> STANDARD	

INFLUENCE FACTORS		
A. NO ROAD	E. SZ/SHAPE	I. WATER FRONT
B. TOPGRHY	F. RESTRICT	J. OTHER/CDU
C. Ex Front	G. WOOD LT	
D. QUANTITY	H. VACANCY	

		EX WALL	A	ROOFING	A	WINDOW	A	DOORS	A	FOUNDATION	A	FRAMING	A	
		STONE	<input type="checkbox"/>	GABLE/HIP	<input type="checkbox"/>	STORE FRT	<input type="checkbox"/>	OVERHEAD	<input type="checkbox"/>	SLAB	<input type="checkbox"/>	PRE ENG	<input type="checkbox"/>	
CLASS/QUALITY RANK		BRICK	<input type="checkbox"/>	SHED/FLAT	<input type="checkbox"/>	CASEMENT	<input type="checkbox"/>			CRAWL	<input type="checkbox"/>	STEEL	<input type="checkbox"/>	
A) FP STRUCT. STEEL FRAME	1. BASIC	CON BLK	<input type="checkbox"/>	CON DECK	<input type="checkbox"/>	DBLH	<input type="checkbox"/>			PILE/COL	<input type="checkbox"/>	REINF CONC	<input type="checkbox"/>	
B) R.C. FRAME	2. FAIR	WD/MTL	<input type="checkbox"/>	MTL DECK	<input type="checkbox"/>	SLIDE BY	<input type="checkbox"/>			REINFOR	<input type="checkbox"/>	CB/MASON	<input type="checkbox"/>	
C) MASONRY BEARING WALLS	3. AVE	ENAM STL	<input type="checkbox"/>	WD DECK	<input type="checkbox"/>	CANOPY	A			STEEL	<input type="checkbox"/>	FRAME	<input type="checkbox"/>	
D) WD OR STEEL FR EX. WALLS	4. GOOD	ALUM/VYL	<input type="checkbox"/>	METAL	<input type="checkbox"/>	LIGHTED	<input type="checkbox"/>	STEEL INS	<input type="checkbox"/>	BRICK	<input type="checkbox"/>	POLE	<input type="checkbox"/>	
S) METAL M) MILL P) POLE	5. EXCEL	CON PANEL	<input type="checkbox"/>	ASPH	<input type="checkbox"/>	SOFFITS	<input type="checkbox"/>	WOOD	<input type="checkbox"/>	STONE	<input type="checkbox"/>	TILT UP	<input type="checkbox"/>	
TOTAL AREA	PERIMETER	0	PLATE GLS	<input type="checkbox"/>	RUBBER	<input type="checkbox"/>	C S W	<input type="checkbox"/>	MTL	<input type="checkbox"/>	CON BLK	<input type="checkbox"/>	SANDWICH	<input type="checkbox"/>
# STORIES	STORY HT		STUCCO	<input type="checkbox"/>	BUILT UP	<input type="checkbox"/>	FACADE	A	GLASS	<input type="checkbox"/>	FRAME	<input type="checkbox"/>	STANDARD	<input type="checkbox"/>
AGE	SPRINKLER		INSULATED	<input type="checkbox"/>	INSULATED	<input type="checkbox"/>			STANDARD	<input type="checkbox"/>	STANDARD	<input type="checkbox"/>		

H.V.A.C.		FLOORS					PARTITIONS					INTERIOR FINISH										
Electric	<input type="checkbox"/>	Electric Wall	<input type="checkbox"/>	CONCRETE	<input type="checkbox"/>	B	1	2	3	U	MASONRY	<input type="checkbox"/>	<input type="checkbox"/>	<input type="checkbox"/>	<input type="checkbox"/>	<input type="checkbox"/>	UNFINISHED	<input type="checkbox"/>	<input type="checkbox"/>	<input type="checkbox"/>	<input type="checkbox"/>	<input type="checkbox"/>
Forced Air Unit	<input type="checkbox"/>	Hot Water	<input type="checkbox"/>	WOOD	<input type="checkbox"/>	<input type="checkbox"/>	<input type="checkbox"/>	<input type="checkbox"/>	<input type="checkbox"/>	<input type="checkbox"/>	WD STUD	<input type="checkbox"/>	<input type="checkbox"/>	<input type="checkbox"/>	<input type="checkbox"/>	<input type="checkbox"/>	FINISH OPEN	<input type="checkbox"/>	<input type="checkbox"/>	<input type="checkbox"/>	<input type="checkbox"/>	<input type="checkbox"/>
Hot Water, Rad	<input type="checkbox"/>	Space/ Wall Furnace	<input type="checkbox"/>	TILE A Q V T	<input type="checkbox"/>	<input type="checkbox"/>	<input type="checkbox"/>	<input type="checkbox"/>	<input type="checkbox"/>	<input type="checkbox"/>	MTL STUD	<input type="checkbox"/>	<input type="checkbox"/>	<input type="checkbox"/>	<input type="checkbox"/>	<input type="checkbox"/>	FINISH DIV	<input type="checkbox"/>	<input type="checkbox"/>	<input type="checkbox"/>	<input type="checkbox"/>	<input type="checkbox"/>
Steam	<input type="checkbox"/>	Warm & Cld Air	<input type="checkbox"/>	CARPET	<input type="checkbox"/>	<input type="checkbox"/>	<input type="checkbox"/>	<input type="checkbox"/>	<input type="checkbox"/>	<input type="checkbox"/>	CEILINGS	B	1	2	3	U	PANEL	<input type="checkbox"/>	<input type="checkbox"/>	<input type="checkbox"/>	<input type="checkbox"/>	<input type="checkbox"/>
Ventilation	<input type="checkbox"/>	Heat Pump	<input type="checkbox"/>	ASPHALT	<input type="checkbox"/>	<input type="checkbox"/>	<input type="checkbox"/>	<input type="checkbox"/>	<input type="checkbox"/>	<input type="checkbox"/>	ACCUT/PANEL	<input type="checkbox"/>	<input type="checkbox"/>	<input type="checkbox"/>	<input type="checkbox"/>	<input type="checkbox"/>	PLASTER / DW	<input type="checkbox"/>	<input type="checkbox"/>	<input type="checkbox"/>	<input type="checkbox"/>	<input type="checkbox"/>
Package Unit	<input type="checkbox"/>	Ind TW Heat Pump	<input type="checkbox"/>	GRAVEL	<input type="checkbox"/>	<input type="checkbox"/>	<input type="checkbox"/>	<input type="checkbox"/>	<input type="checkbox"/>	<input type="checkbox"/>	PLASTER/DW	<input type="checkbox"/>	<input type="checkbox"/>	<input type="checkbox"/>	<input type="checkbox"/>	<input type="checkbox"/>	BLOCK	<input type="checkbox"/>	<input type="checkbox"/>	<input type="checkbox"/>	<input type="checkbox"/>	<input type="checkbox"/>
Hot & Cld Water	<input type="checkbox"/>	Evaporated Cool	<input type="checkbox"/>	DIRT	<input type="checkbox"/>	<input type="checkbox"/>	<input type="checkbox"/>	<input type="checkbox"/>	<input type="checkbox"/>	<input type="checkbox"/>	SUSP/OPEN	<input type="checkbox"/>	<input type="checkbox"/>	<input type="checkbox"/>	<input type="checkbox"/>	<input type="checkbox"/>	GLAZED TILE	<input type="checkbox"/>	<input type="checkbox"/>	<input type="checkbox"/>	<input type="checkbox"/>	<input type="checkbox"/>
Floor Furnace	<input type="checkbox"/>	Co-Ray-Vac	<input type="checkbox"/>	STANDARD	<input type="checkbox"/>						STANDARD	<input type="checkbox"/>					STANDARD	<input type="checkbox"/>				

Complete HVAC	<input type="checkbox"/>	No Heat	<input type="checkbox"/>	PLUMBING					A	LIGHTING					A		
Refrig. Cooling	<input type="checkbox"/>	Standard	<input type="checkbox"/>	NO PLUMBING					<input type="checkbox"/>	EXTRA FIXTURES					<input type="checkbox"/>	METAL HALIDE	<input type="checkbox"/>
				2 FIXTURE BATH						STANDARD					<input type="checkbox"/>	STANDARD	<input type="checkbox"/>
				3 FIXTURE BATH											<input type="checkbox"/>		<input type="checkbox"/>

YARD ITEMS		CONST	HT	SIZE X SIZE	FL	AREA	UNITS	AGE	REM	CND	GRD	\$/UNIT	UNADJUSTED \$	PHY	FC	EC	MARKET VALUE
A	901.001:Paving: Asphalt				1	9,926		2000		G	N	.00	0	0	0	0	0

YARD ITEMS		CONST	HT	SIZE X SIZE	FL	AREA	UNITS	AGE	REM	CND	GRD	\$/UNIT	UNADJUSTED \$	PHY	FC	EC	MARKET VALUE
A	401.009:Apts 4+ Units: 475-524.99 Mont			48 X 24	1	1,152	2	1977	1977A	A	A	35,100.00	70,200	0	0	0	70,200

AMENITY TOTAL																0	
LESS LAND: 23,270																TOTAL IMPR	187,330

COMMENTS

BLDG A 2 UNITS WITH 2 BDRMS & 1 BTHRM EACH @ \$292.25/MO BLDG B 2 UNITS WITH 1 BDRM & 1 BTHRM EACH @ \$232.50/MO BLDG C 2 UNITS WITH 2 BDRMS & 1 BTHRM EACH @ \$385/MO



39-017600.0000

RECOVERY TWP-FT RECOVERY CO
 FT RECOVERY SD
 10-20-252-023

LEGAL INFORMATION

MCDANIELS ADDITION LOTS 22 & 23
 ALSO 1/2 VACATED ST.
 TO EAST

LENNCO PROPERTIES LLC
 LENNCO PROPERTIES LLC
 409 E BROADWAY ST APT A PO BOX 366
 FORT RECOVERY, OH 45846

COMMENT

Neighborhood CVIL39	
Map:	
Block:	
Card:	
Bk:	Pg:

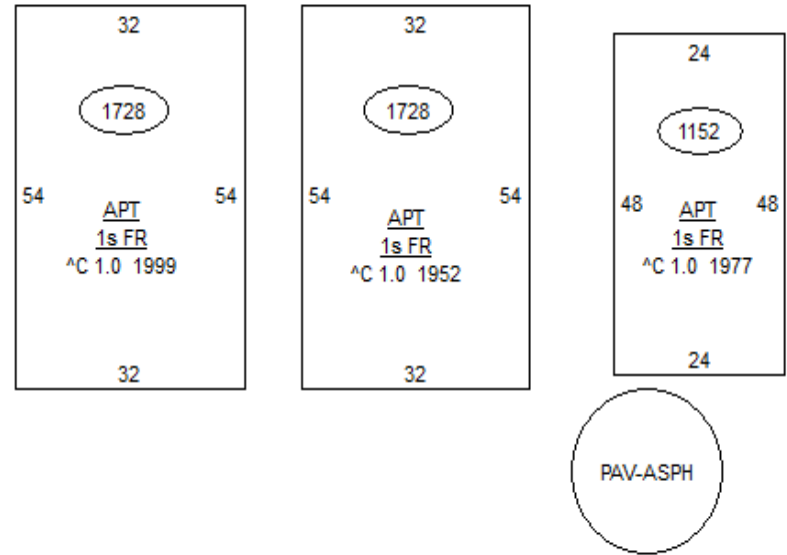

Sales Data						Date
Date	Amount	Deed:Conv#	Use	Valid	Lister:	03/09/23
07/21/1997	58,000		: A-M : 0 401	<input type="checkbox"/>	Pricer:	
				<input type="checkbox"/>	Reviewer:	
				<input type="checkbox"/>	Final:	
				<input type="checkbox"/>	Call Back:	
				<input type="checkbox"/>	Visit:	

VALUATION SUMMARY			
VALUE YEAR			
REASON FOR CHANGE			
ESTIMATED MARKET VALUE	<u>LAND</u>		
	<u>IMPR</u>		
	<u>TOTAL</u>		
ASSESSED VALUE	<u>LAND</u>		
	<u>IMPR</u>		
	<u>TOTAL</u>		

STREET/ROAD	TOPOGRAPHY	PU-UTILITIES-PR	ZONING
<input type="checkbox"/> PAVED	<input type="checkbox"/> LEVEL	<input checked="" type="checkbox"/> WATER	<input type="checkbox"/> AG-RES
<input type="checkbox"/> GRAVEL	<input type="checkbox"/> HIGH	<input checked="" type="checkbox"/> SEWER	<input checked="" type="checkbox"/> COMMERCIAL
<input type="checkbox"/> DIRT	<input type="checkbox"/> LOW	<input type="checkbox"/> GAS	<input type="checkbox"/> INDUSTRIAL
<input type="checkbox"/> SIDEWALKS	<input type="checkbox"/> ROLLING	<input checked="" type="checkbox"/> ELECTRIC	
<input type="checkbox"/> CURBS	<input type="checkbox"/> STANDARD	<input type="checkbox"/> STANDARD	

INFLUENCE FACTORS		
A. NO ROAD	E. SZ/SHAPE	I. WATER FRONT
B. TOPGRHY	F. RESTRICT	J. OTHER/CDU
C. Ex Front	G. WOOD LT	
D. QUANTITY	H. VACANCY	

LAND TYPE	SIZE	M	RATE	C	INF	M	VALUE	C
Totals:						23,270	0	23,270

		EX WALL	B	ROOFING	B	WINDOW	B	DOORS	B	FOUNDATION	B	FRAMING	B	
		STONE	<input type="checkbox"/>	GABLE/HIP	<input type="checkbox"/>	STORE FRT	<input type="checkbox"/>	OVERHEAD	<input type="checkbox"/>	SLAB	<input type="checkbox"/>	PRE ENG	<input type="checkbox"/>	
CLASS/QUALITY RANK		BRICK	<input type="checkbox"/>	SHED/FLAT	<input type="checkbox"/>	CASEMENT	<input type="checkbox"/>			CRAWL	<input type="checkbox"/>	STEEL	<input type="checkbox"/>	
A) FP STRUCT. STEEL FRAME	1. BASIC	CON BLK	<input type="checkbox"/>	CON DECK	<input type="checkbox"/>	DBLH	<input type="checkbox"/>			PILE/COL	<input type="checkbox"/>	REINF CONC	<input type="checkbox"/>	
B) R.C. FRAME	2. FAIR	WD/MTL	<input type="checkbox"/>	MTL DECK	<input type="checkbox"/>	SLIDE BY	<input type="checkbox"/>			REINFOR	<input type="checkbox"/>	CB/MASON	<input type="checkbox"/>	
C) MASONRY BEARING WALLS	3. AVE	ENAM STL	<input type="checkbox"/>	WD DECK	<input type="checkbox"/>	CANOPY	B			STEEL	<input type="checkbox"/>	FRAME	<input type="checkbox"/>	
D) WD OR STEEL FR EX. WALLS	4. GOOD	ALUM/VYL	<input type="checkbox"/>	METAL	<input type="checkbox"/>	LIGHTED	<input type="checkbox"/>	STEEL INS	<input type="checkbox"/>	BRICK	<input type="checkbox"/>	POLE	<input type="checkbox"/>	
S) METAL M) MILL P) POLE	5. EXCEL	CON PANEL	<input type="checkbox"/>	ASPH	<input type="checkbox"/>	SOFFITS	<input type="checkbox"/>	WOOD	<input type="checkbox"/>	STONE	<input type="checkbox"/>	TILT UP	<input type="checkbox"/>	
TOTAL AREA	PERIMETER	0	PLATE GLS	<input type="checkbox"/>	RUBBER	<input type="checkbox"/>	C S W	<input type="checkbox"/>	MTL	<input type="checkbox"/>	CON BLK	<input type="checkbox"/>	SANDWICH	<input type="checkbox"/>
# STORIES	STORY HT		STUCCO	<input type="checkbox"/>	BUILT UP	<input type="checkbox"/>	FACADE	B	GLASS	<input type="checkbox"/>	FRAME	<input type="checkbox"/>	STANDARD	<input type="checkbox"/>
AGE	SPRINKLER		INSULATED	<input type="checkbox"/>	INSULATED	<input type="checkbox"/>			STANDARD	<input type="checkbox"/>	STANDARD	<input type="checkbox"/>		

H.V.A.C.		FLOORS					PARTITIONS					INTERIOR FINISH										
Electric	<input type="checkbox"/>	Electric Wall	<input type="checkbox"/>	CONCRETE	<input type="checkbox"/>	<input type="checkbox"/>	<input type="checkbox"/>	<input type="checkbox"/>	<input type="checkbox"/>	<input type="checkbox"/>	MASONRY	<input type="checkbox"/>	<input type="checkbox"/>	<input type="checkbox"/>	<input type="checkbox"/>	<input type="checkbox"/>	UNFINISHED	<input type="checkbox"/>	<input type="checkbox"/>	<input type="checkbox"/>	<input type="checkbox"/>	<input type="checkbox"/>
Forced Air Unit	<input type="checkbox"/>	Hot Water	<input type="checkbox"/>	WOOD	<input type="checkbox"/>	<input type="checkbox"/>	<input type="checkbox"/>	<input type="checkbox"/>	<input type="checkbox"/>	<input type="checkbox"/>	WD STUD	<input type="checkbox"/>	<input type="checkbox"/>	<input type="checkbox"/>	<input type="checkbox"/>	<input type="checkbox"/>	FINISH OPEN	<input type="checkbox"/>	<input type="checkbox"/>	<input type="checkbox"/>	<input type="checkbox"/>	<input type="checkbox"/>
Hot Water, Rad	<input type="checkbox"/>	Space/ Wall Furnace	<input type="checkbox"/>	TILE A Q V T	<input type="checkbox"/>	<input type="checkbox"/>	<input type="checkbox"/>	<input type="checkbox"/>	<input type="checkbox"/>	<input type="checkbox"/>	MTL STUD	<input type="checkbox"/>	<input type="checkbox"/>	<input type="checkbox"/>	<input type="checkbox"/>	<input type="checkbox"/>	FINISH DIV	<input type="checkbox"/>	<input type="checkbox"/>	<input type="checkbox"/>	<input type="checkbox"/>	<input type="checkbox"/>
Steam	<input type="checkbox"/>	Warm & Cld Air	<input type="checkbox"/>	CARPET	<input type="checkbox"/>	<input type="checkbox"/>	<input type="checkbox"/>	<input type="checkbox"/>	<input type="checkbox"/>	<input type="checkbox"/>	CEILINGS	B	1	2	3	U	PANEL	<input type="checkbox"/>	<input type="checkbox"/>	<input type="checkbox"/>	<input type="checkbox"/>	<input type="checkbox"/>
Ventilation	<input type="checkbox"/>	Heat Pump	<input type="checkbox"/>	ASPHALT	<input type="checkbox"/>	<input type="checkbox"/>	<input type="checkbox"/>	<input type="checkbox"/>	<input type="checkbox"/>	<input type="checkbox"/>	ACCUT/PANEL	<input type="checkbox"/>	<input type="checkbox"/>	<input type="checkbox"/>	<input type="checkbox"/>	<input type="checkbox"/>	PLASTER / DW	<input type="checkbox"/>	<input type="checkbox"/>	<input type="checkbox"/>	<input type="checkbox"/>	<input type="checkbox"/>
Package Unit	<input type="checkbox"/>	Ind TW Heat Pump	<input type="checkbox"/>	GRAVEL	<input type="checkbox"/>	<input type="checkbox"/>	<input type="checkbox"/>	<input type="checkbox"/>	<input type="checkbox"/>	<input type="checkbox"/>	PLASTER/DW	<input type="checkbox"/>	<input type="checkbox"/>	<input type="checkbox"/>	<input type="checkbox"/>	<input type="checkbox"/>	BLOCK	<input type="checkbox"/>	<input type="checkbox"/>	<input type="checkbox"/>	<input type="checkbox"/>	<input type="checkbox"/>
Hot & Cld Water	<input type="checkbox"/>	Evaporated Cool	<input type="checkbox"/>	DIRT	<input type="checkbox"/>	<input type="checkbox"/>	<input type="checkbox"/>	<input type="checkbox"/>	<input type="checkbox"/>	<input type="checkbox"/>	SUSP/OPEN	<input type="checkbox"/>	<input type="checkbox"/>	<input type="checkbox"/>	<input type="checkbox"/>	<input type="checkbox"/>	GLAZED TILE	<input type="checkbox"/>	<input type="checkbox"/>	<input type="checkbox"/>	<input type="checkbox"/>	<input type="checkbox"/>
Floor Furnace	<input type="checkbox"/>	Co-Ray-Vac	<input type="checkbox"/>	STANDARD	<input type="checkbox"/>					<input type="checkbox"/>	STANDARD	<input type="checkbox"/>					STANDARD	<input type="checkbox"/>				

Complete HVAC	<input type="checkbox"/>	No Heat	<input type="checkbox"/>	PLUMBING					B	LIGHTING					B
Refrig. Cooling	<input type="checkbox"/>	Standard	<input type="checkbox"/>	NO PLUMBING					<input type="checkbox"/>	EXTRA FIXTURES					<input type="checkbox"/>
				2 FIXTURE BATH						STANDARD					<input type="checkbox"/>
				3 FIXTURE BATH						MERCURY VAP					<input type="checkbox"/>

ITEM	CONST	HT	SIZE X SIZE	FL	AREA	UNITS	AGE	REM	CND	GRD	\$/UNIT	UNADJUSTED \$	PHY	FC	EC	MARKET VALUE
------	-------	----	-------------	----	------	-------	-----	-----	-----	-----	---------	---------------	-----	----	----	--------------

B	401.009:Apts 4+ Units: 475-524.99 Mont		54 X 32	1	1,728	2	1952	1989A	A	F	35,100.00	70,200	0	0	0	70,200
---	--	--	---------	---	-------	---	------	-------	---	---	-----------	--------	---	---	---	--------

AMENITY TOTAL															0	
LESS LAND: 23,270															TOTAL IMPR	187,330

COMMENTS



39-017600.0000

RECOVERY TWP-FT RECOVERY CO
 FT RECOVERY SD
 10-20-252-023

LEGAL INFORMATION

MCDANIELS ADDITION LOTS 22 & 23
 ALSO 1/2 VACATED ST.
 TO EAST

LENNCO PROPERTIES LLC
 LENNCO PROPERTIES LLC
 409 E BROADWAY ST APT A PO BOX 366
 FORT RECOVERY, OH 45846

COMMENT

Neighborhood CVIL39	
Map:	
Block:	
Card:	
Bk:	Pg:

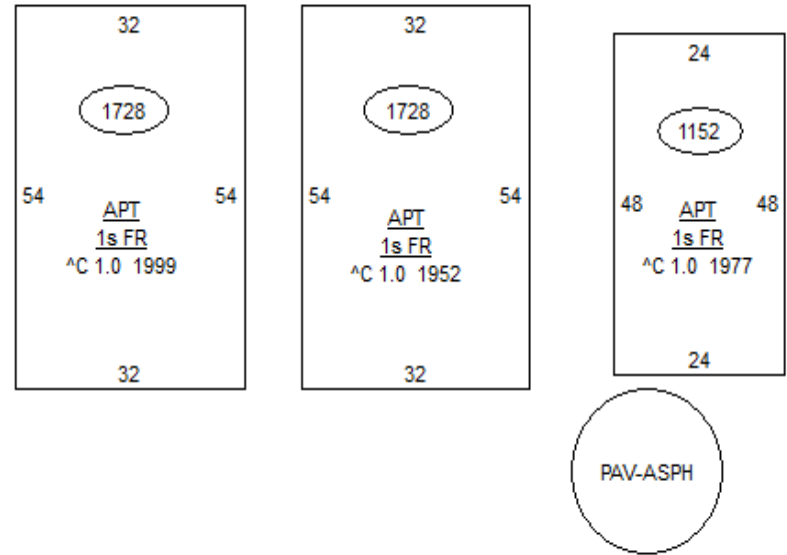

Sales Data						Date
Date	Amount	Deed:Conv#	Use	Valid	Lister:	03/09/23
04/09/2021	400,000		2:WDC : 256	401	<input checked="" type="checkbox"/>	Pricer:
02/20/2013	0		6:QCE : X : 0	401	<input type="checkbox"/>	Reviewer:
12/05/2012	325,000		3:WDC : 773	401	<input type="checkbox"/>	Final:
07/21/1997	58,000		: A-M : 0	401	<input type="checkbox"/>	Call Back:
					<input type="checkbox"/>	Visit:

VALUATION SUMMARY			
VALUE YEAR			
REASON FOR CHANGE			
ESTIMATED MARKET VALUE	<u>LAND</u>		
	<u>IMPR</u>		
	<u>TOTAL</u>		
ASSESSED VALUE	<u>LAND</u>		
	<u>IMPR</u>		
	<u>TOTAL</u>		

STREET/ROAD	TOPOGRAPHY	PU-UTILITIES-PR	ZONING
<input type="checkbox"/> PAVED	<input type="checkbox"/> LEVEL	<input checked="" type="checkbox"/> WATER	<input type="checkbox"/> AG-RES
<input type="checkbox"/> GRAVEL	<input type="checkbox"/> HIGH	<input checked="" type="checkbox"/> SEWER	<input checked="" type="checkbox"/> COMMERCIAL
<input type="checkbox"/> DIRT	<input type="checkbox"/> LOW	<input type="checkbox"/> GAS	<input type="checkbox"/> INDUSTRIAL
<input type="checkbox"/> SIDEWALKS	<input type="checkbox"/> ROLLING	<input checked="" type="checkbox"/> ELECTRIC	
<input type="checkbox"/> CURBS	<input type="checkbox"/> STANDARD	<input type="checkbox"/> STANDARD	

INFLUENCE FACTORS		
A. NO ROAD	E. SZ/SHAPE	I. WATER FRONT
B. TOPGRHY	F. RESTRICT	J. OTHER/CDU
C. Ex Front	G. WOOD LT	
D. QUANTITY	H. VACANCY	

LAND TYPE	SIZE	M	RATE	C	INF	M	VALUE	C
Totals:						23,270	0	23,270

			EX WALL	C	ROOFING	C	WINDOW	C	DOORS	C	FOUNDATION	C	FRAMING	C	
			STONE	<input type="checkbox"/>	GABLE/HIP	<input type="checkbox"/>	STORE FRT	<input type="checkbox"/>	OVERHEAD		SLAB	<input type="checkbox"/>	PRE ENG	<input type="checkbox"/>	
CLASS/QUALITY RANK			BRICK	<input type="checkbox"/>	SHED/FLAT	<input type="checkbox"/>	CASEMENT	<input type="checkbox"/>			CRAWL	<input type="checkbox"/>	STEEL	<input type="checkbox"/>	
A) FP STRUCT. STEEL FRAME	1. BASIC		CON BLK	<input type="checkbox"/>	CON DECK	<input type="checkbox"/>	DBLH	<input type="checkbox"/>			PILE/COL	<input type="checkbox"/>	REINF CONC	<input type="checkbox"/>	
B) R.C. FRAME	2. FAIR		WD/MTL	<input type="checkbox"/>	MTL DECK	<input type="checkbox"/>	SLIDE BY	<input type="checkbox"/>			REINFOR	<input type="checkbox"/>	CB/MASON	<input type="checkbox"/>	
C) MASONRY BEARING WALLS			3. AVE	ENAM STL	<input type="checkbox"/>	WD DECK	<input type="checkbox"/>	CANOPI	C		STEEL	<input type="checkbox"/>	FRAME	<input type="checkbox"/>	
D) WD OR STEEL FR EX. WALLS	4. GOOD		ALUM/VYL	<input type="checkbox"/>	METAL	<input type="checkbox"/>	LIGHTED	<input type="checkbox"/>	STEEL INS	<input type="checkbox"/>	BRICK	<input type="checkbox"/>	POLE	<input type="checkbox"/>	
S) METAL M) MILL P) POLE	5. EXCEL		CON PANEL	<input type="checkbox"/>	ASPH	<input type="checkbox"/>	SOFFITS	<input type="checkbox"/>	WOOD	<input type="checkbox"/>	STONE	<input type="checkbox"/>	TILT UP	<input type="checkbox"/>	
TOTAL AREA	PERIMETER		0	PLATE GLS	<input type="checkbox"/>	RUBBER	<input type="checkbox"/>	C S W	<input type="checkbox"/>	MTL	<input type="checkbox"/>	CON BLK	<input type="checkbox"/>	SANDWICH	<input type="checkbox"/>
# STORIES	STORY HT			STUCCO	<input type="checkbox"/>	BUILT UP	<input type="checkbox"/>	FACADE	C	GLASS	<input type="checkbox"/>	FRAME	<input type="checkbox"/>	STANDARD	<input type="checkbox"/>
AGE	SPRINKLER			INSULATED	<input type="checkbox"/>	INSULATED	<input type="checkbox"/>			STANDARD	<input type="checkbox"/>	STANDARD	<input type="checkbox"/>		

H.V.A.C.		FLOORS					PARTITIONS					INTERIOR FINISH										
Electric	<input type="checkbox"/>	Electric Wall	<input type="checkbox"/>	CONCRETE	<input type="checkbox"/>	B	1	2	3	U	MASONRY	<input type="checkbox"/>	<input type="checkbox"/>	<input type="checkbox"/>	<input type="checkbox"/>	<input type="checkbox"/>	UNFINISHED	<input type="checkbox"/>	<input type="checkbox"/>	<input type="checkbox"/>	<input type="checkbox"/>	<input type="checkbox"/>
Forced Air Unit	<input type="checkbox"/>	Hot Water	<input type="checkbox"/>	WOOD	<input type="checkbox"/>	<input type="checkbox"/>	<input type="checkbox"/>	<input type="checkbox"/>	<input type="checkbox"/>	<input type="checkbox"/>	WD STUD	<input type="checkbox"/>	<input type="checkbox"/>	<input type="checkbox"/>	<input type="checkbox"/>	<input type="checkbox"/>	FINISH OPEN	<input type="checkbox"/>	<input type="checkbox"/>	<input type="checkbox"/>	<input type="checkbox"/>	<input type="checkbox"/>
Hot Water, Rad	<input type="checkbox"/>	Space/ Wall Furnace	<input type="checkbox"/>	TILE A Q V T	<input type="checkbox"/>	<input type="checkbox"/>	<input type="checkbox"/>	<input type="checkbox"/>	<input type="checkbox"/>	<input type="checkbox"/>	MTL STUD	<input type="checkbox"/>	<input type="checkbox"/>	<input type="checkbox"/>	<input type="checkbox"/>	<input type="checkbox"/>	FINISH DIV	<input type="checkbox"/>	<input type="checkbox"/>	<input type="checkbox"/>	<input type="checkbox"/>	<input type="checkbox"/>
Steam	<input type="checkbox"/>	Warm & Cld Air	<input type="checkbox"/>	CARPET	<input type="checkbox"/>	<input type="checkbox"/>	<input type="checkbox"/>	<input type="checkbox"/>	<input type="checkbox"/>	<input type="checkbox"/>	CEILINGS	B	1	2	3	U	PANEL	<input type="checkbox"/>	<input type="checkbox"/>	<input type="checkbox"/>	<input type="checkbox"/>	<input type="checkbox"/>
Ventilation	<input type="checkbox"/>	Heat Pump	<input type="checkbox"/>	ASPHALT	<input type="checkbox"/>	<input type="checkbox"/>	<input type="checkbox"/>	<input type="checkbox"/>	<input type="checkbox"/>	<input type="checkbox"/>	ACCUT/PANEL	<input type="checkbox"/>	<input type="checkbox"/>	<input type="checkbox"/>	<input type="checkbox"/>	<input type="checkbox"/>	PLASTER / DW	<input type="checkbox"/>	<input type="checkbox"/>	<input type="checkbox"/>	<input type="checkbox"/>	<input type="checkbox"/>
Package Unit	<input type="checkbox"/>	Ind TW Heat Pump	<input type="checkbox"/>	GRAVEL	<input type="checkbox"/>	<input type="checkbox"/>	<input type="checkbox"/>	<input type="checkbox"/>	<input type="checkbox"/>	<input type="checkbox"/>	PLASTER/DW	<input type="checkbox"/>	<input type="checkbox"/>	<input type="checkbox"/>	<input type="checkbox"/>	<input type="checkbox"/>	BLOCK	<input type="checkbox"/>	<input type="checkbox"/>	<input type="checkbox"/>	<input type="checkbox"/>	<input type="checkbox"/>
Hot & Cld Water	<input type="checkbox"/>	Evaporated Cool	<input type="checkbox"/>	DIRT	<input type="checkbox"/>	<input type="checkbox"/>	<input type="checkbox"/>	<input type="checkbox"/>	<input type="checkbox"/>	<input type="checkbox"/>	SUSP/OPEN	<input type="checkbox"/>	<input type="checkbox"/>	<input type="checkbox"/>	<input type="checkbox"/>	<input type="checkbox"/>	GLAZED TILE	<input type="checkbox"/>	<input type="checkbox"/>	<input type="checkbox"/>	<input type="checkbox"/>	<input type="checkbox"/>
Floor Furnace	<input type="checkbox"/>	Co-Ray-Vac	<input type="checkbox"/>	STANDARD	<input type="checkbox"/>						STANDARD	<input type="checkbox"/>					STANDARD	<input type="checkbox"/>				

Complete HVAC		<input type="checkbox"/>	No Heat	<input type="checkbox"/>	PLUMBING					C	LIGHTING					C												
Refrig. Cooling		<input type="checkbox"/>	Standard	<input type="checkbox"/>	NO PLUMBING					<input type="checkbox"/>	EXTRA FIXTURES					<input type="checkbox"/>	FLUORESCENT					<input type="checkbox"/>	METAL HALIDE					<input type="checkbox"/>
					2 FIXTURE BATH						STANDARD					<input type="checkbox"/>	SODIUM VAP					<input type="checkbox"/>	STANDARD					<input type="checkbox"/>
YARD ITEMS					3 FIXTURE BATH											<input type="checkbox"/>	MERCURY VAP					<input type="checkbox"/>						<input type="checkbox"/>

ITEM	CONST	HT	SIZE X SIZE	FL	AREA	UNITS	AGE	REM	CND	GRD	\$/UNIT	UNADJUSTED \$	PHY	FC	EC	MARKET VALUE
C 401.009:Apts 4+ Units: 475-524.99 Mont			54 X 32	1	1,728	2	1999		A	A	35,100.00	70,200	0	0	0	70,200

AMENITY TOTAL 0
 LESS LAND: 23,270 TOTAL IMPR 187,330

COMMENTS