

RECOVERY TWP / FT RECOVERY SD

10-19-403-001

Property Class: 510

Neighborhood  
009385-R150

Map: 06  
Block: 04  
Card: 07

Bk: Pg:

38-030700.0000

**BRUNS AARON M & MARIA A**  
BRUNS AARON M & MARIA A  
442 LOWRY RD  
FORT RECOVERY, OH 45846

**LEGAL INFORMATION**  
CENT PT SE FR

RTS: 001-07-19  
Acres:7.0000

	OWNERSHIP	ADDRESS	CITY	STATE	ZIP	DATE	AMOUNT	DEED:CONV#	JS	VALID
1	BRUNS AARON M & MARIA A	442 LOWRY RD	FORT RECOVERY	OH	45846	07/14/2020	215,000	2:WDC : 453	<input type="checkbox"/>	<input checked="" type="checkbox"/>
2	LINK CARL J & CINDY	1310 BURRVILLE RD	FORT RECOVERY	OH	45846	12/22/2008	119,000	WDC : A-M : 822	<input type="checkbox"/>	<input type="checkbox"/>
3	KAUP ALVIN D	442 LOWRY RD	FT RECOVERY	OH	45846	01/26/1998	0	: X : 0	<input type="checkbox"/>	<input type="checkbox"/>

X:  TTO LISTER: BTC DATE: 07/06/2010 TIME: 12:00:00 AM  LETTER  LETTER REC'D GIS CODE

STREET/ROAD	TOPOGRAPHY	PU-UTILITIES-PR	NEIGHBORHOOD	INFLUENCE FACTORS				PROPERTY LOCATION	
<input checked="" type="checkbox"/> PAVED	<input checked="" type="checkbox"/> LEVEL	<input type="checkbox"/> WATER	<input type="checkbox"/> IMPROVING	<input type="checkbox"/> A. NO ROAD	<input type="checkbox"/> F. RESTRICT	442 LOWRY RD, FT RECOVERY			
<input type="checkbox"/> GRAVEL	<input type="checkbox"/> HIGH	<input type="checkbox"/> SEWER	<input type="checkbox"/> STATIC	<input type="checkbox"/> B. TOPGRHY	<input type="checkbox"/> G. WOOD LT	COMMENT TY2022:Net Gen=\$1,956.64, Other Assessment=\$2.08 DE10 REVD IN FIELD RMV & CORR OUTBLDGS ANIMALS AGAINST HOUSE COULDNT WALK AROUND HOME DE17 DESKTOP REVIEW//RMV COOP ADD SHED			
<input type="checkbox"/> DIRT	<input type="checkbox"/> LOW	<input type="checkbox"/> GAS	<input type="checkbox"/> DECLINING	<input type="checkbox"/> C. Ex Front	<input type="checkbox"/> H. VACANCY				
<input type="checkbox"/> SIDEWALKS	<input type="checkbox"/> ROLLING	<input type="checkbox"/> ELECTRIC	<input type="checkbox"/> OLD	<input type="checkbox"/> D. QUANTITY	<input type="checkbox"/> I. WATER FRONT				
<input type="checkbox"/> CURBS	<input type="checkbox"/> STANDARD	<input checked="" type="checkbox"/> STANDARD	<input type="checkbox"/> STANDARD	<input type="checkbox"/> E. SZ/SHAPE	<input type="checkbox"/> J. OTHER/CDU				
LAND COMPUTATIONS									
LAND TYPE	SIZE	M	RATE	C	INF	M	VALUE	C	
HS:Home Site	AC:1	34360				34,400	0		
SM:Small Acreage	AC:6	7500				45,000	0		
Total Acres: 7.0000						TOTAL	79,400	0	

VALUATION SUMMARY					
VALUE YEAR	2023	2020	2017	2017	
REASON FOR CHANGE	RAPP	RAPP	RAPP	MISC	
APPRAISED	79,400	62,400	52,500	56,100	
VALUE	130,800	112,100	88,800	69,200	
	TOTAL	174,500	141,300	125,300	
ASSESSED	27,790	21,840	18,380	19,640	
VALUE	45,780	39,240	31,080	24,220	
	TOTAL	61,080	49,460	43,860	

OCCUPANCY		EXTERIOR		FLOOR	AREA	CONST	VALUE
<input checked="" type="checkbox"/> SF	<input type="checkbox"/> DU	<input type="checkbox"/> TR	<input type="checkbox"/> WOOD	1	872	FR	145,100
<input type="checkbox"/> CONVERSION	<input type="checkbox"/> STUCCO			.5	240	FR	24,760
<b>BUILDING TYPE</b>		<input checked="" type="checkbox"/> ALM/VYNL					
<input type="checkbox"/> MOBILE HOME	<input type="checkbox"/> CONC BLK						
<input type="checkbox"/> BI/TR LEVEL	<input type="checkbox"/> METAL						
<input type="checkbox"/> MOD/MAN	<input type="checkbox"/> BRICK						
<input type="checkbox"/>	<input type="checkbox"/> STONE						
<b>ROOFING</b>		<b>ROOF TYPE</b>					
<input type="checkbox"/> METAL	<input checked="" type="checkbox"/> GABLE						
<input type="checkbox"/> SLT/TLE	<input type="checkbox"/> HIP						
<input checked="" type="checkbox"/> SHINGLES	<input type="checkbox"/> GAMBREL						
<input type="checkbox"/> SHAKES	<input type="checkbox"/> MANSARD						
<input type="checkbox"/> COMPOSITE	<input type="checkbox"/> FLAT						
<b>FLOORS</b>		B	1	2	3	U	
CONCRETE	<input checked="" type="checkbox"/>	<input type="checkbox"/>	<input type="checkbox"/>	<input type="checkbox"/>	<input type="checkbox"/>	<input type="checkbox"/>	
WOOD	<input type="checkbox"/>	<input checked="" type="checkbox"/>	<input checked="" type="checkbox"/>	<input type="checkbox"/>	<input type="checkbox"/>	<input type="checkbox"/>	
TILE/COMPO	<input type="checkbox"/>	<input type="checkbox"/>	<input type="checkbox"/>	<input type="checkbox"/>	<input type="checkbox"/>	<input type="checkbox"/>	
CARPET	<input checked="" type="checkbox"/>	<input checked="" type="checkbox"/>	<input checked="" type="checkbox"/>	<input type="checkbox"/>	<input type="checkbox"/>	<input type="checkbox"/>	
<b>INT. FINISH</b>		B	1	2	3	U	
PLASTER/DW	<input type="checkbox"/>	<input checked="" type="checkbox"/>	<input checked="" type="checkbox"/>	<input type="checkbox"/>	<input type="checkbox"/>	<input type="checkbox"/>	
PANELING	<input checked="" type="checkbox"/>	<input type="checkbox"/>	<input type="checkbox"/>	<input type="checkbox"/>	<input type="checkbox"/>	<input type="checkbox"/>	
UNFINISHED	<input checked="" type="checkbox"/>	<input type="checkbox"/>	<input type="checkbox"/>	<input type="checkbox"/>	<input type="checkbox"/>	<input type="checkbox"/>	
<b>ACCOMMODATIONS</b>							
# OF ROOMS		5	2				
BEDROOMS		1	2				
FIREPLACES							
<b>HEAT &amp; AC</b>		B	1	2	3	U	
NO HEAT	<input type="checkbox"/>	<input type="checkbox"/>	<input type="checkbox"/>	<input type="checkbox"/>	<input type="checkbox"/>	<input type="checkbox"/>	
CTRL HEAT	<input checked="" type="checkbox"/>	<input checked="" type="checkbox"/>	<input checked="" type="checkbox"/>	<input type="checkbox"/>	<input type="checkbox"/>	<input type="checkbox"/>	
HW/STEAM	<input type="checkbox"/>	<input type="checkbox"/>	<input type="checkbox"/>	<input type="checkbox"/>	<input type="checkbox"/>	<input type="checkbox"/>	
ELECTRIC	<input type="checkbox"/>	<input type="checkbox"/>	<input type="checkbox"/>	<input type="checkbox"/>	<input type="checkbox"/>	<input type="checkbox"/>	
HEAT PUMP	<input type="checkbox"/>	<input type="checkbox"/>	<input type="checkbox"/>	<input type="checkbox"/>	<input type="checkbox"/>	<input type="checkbox"/>	
FLR/WALL	<input type="checkbox"/>	<input type="checkbox"/>	<input type="checkbox"/>	<input type="checkbox"/>	<input type="checkbox"/>	<input type="checkbox"/>	
STVE/SPCE	<input type="checkbox"/>	<input type="checkbox"/>	<input type="checkbox"/>	<input type="checkbox"/>	<input type="checkbox"/>	<input type="checkbox"/>	
GEO THERMAL	<input type="checkbox"/>	<input type="checkbox"/>	<input type="checkbox"/>	<input type="checkbox"/>	<input type="checkbox"/>	<input type="checkbox"/>	
OUTSIDE	<input type="checkbox"/>	<input type="checkbox"/>	<input type="checkbox"/>	<input type="checkbox"/>	<input type="checkbox"/>	<input type="checkbox"/>	
CTRL A/C	<input type="checkbox"/>	<input type="checkbox"/>	<input type="checkbox"/>	<input type="checkbox"/>	<input type="checkbox"/>	<input type="checkbox"/>	
<b>PLUMBING</b>		<b>BASE</b>		<input checked="" type="checkbox"/>			
X FULL BATH							
X HALF BATH							
X FIXTURES							
		BSMT	480				6,860
		<b>SUBTOTAL</b>					176,720
		MULTI-FAMILY #	0				0
		BUILDING TYPE	100%				0
		BSMT FINISH	240 S.F.				3,430
		FIREPLACE #	0				0
		HEATING	0 S.F.				0
		AIR COND	0 S.F.				0
		PLUMBING #	0				0
		GARAGES & CARPORTS					0
		EXTRA FEATURES					14,300
		<b>SUBTOTAL</b>					194,450
		GRADE FACTOR					100 %
		<b>UNADJUSTED VALUE</b>					194,450
		FACTOR					100 %

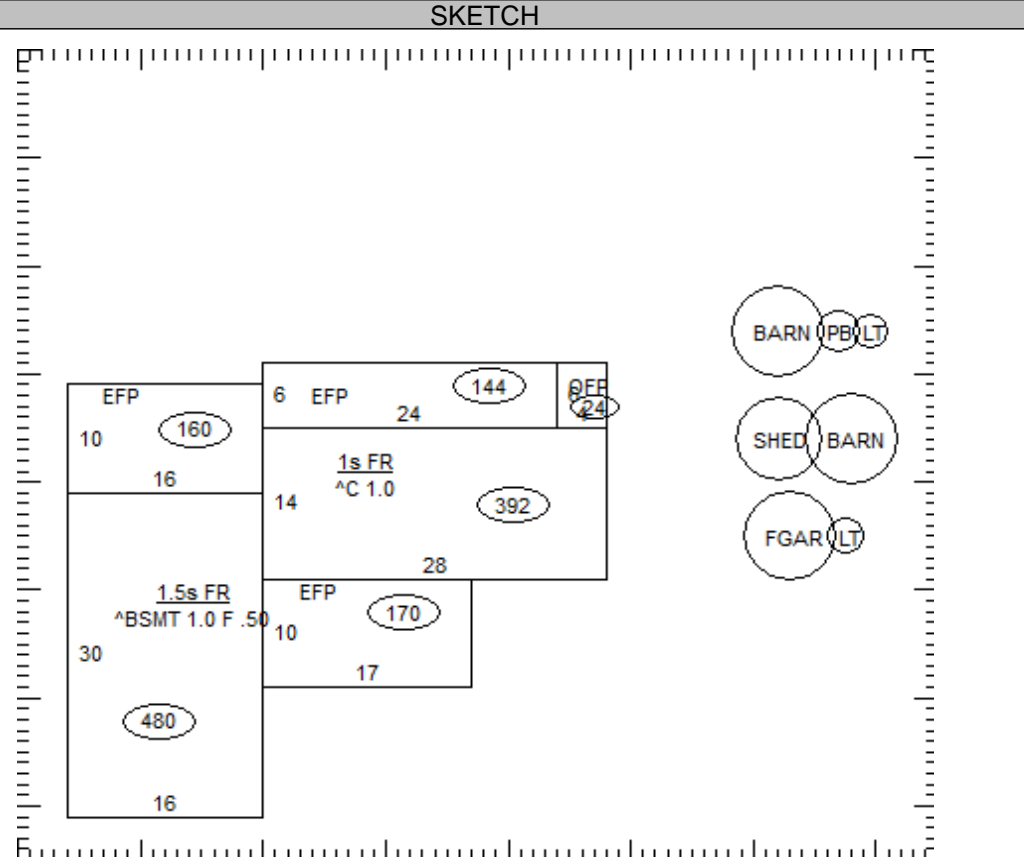

OCCUPANCY	ST.HT	SIZE	AREA	GRADE	PRICE	AGE	REMD	CND	UNADJ VAL	PHYS	PHYS VAL	FUNC	TRUE VAL
DWELLING	1.5	SK	1,112	C		1900		A	194,450	45	106,950		123,000
1 Lean - To		14x26	364	C	4.80	1980		A	1,750	77	400		400
2 Gar - Frame		24x30	720	C	23.70	1960		A	17,060	90	1,710		1,700
3 Barn	14	18x26	468	C	12.00	1952		A	5,620	95	280	DFLT25	200
4 Pole Bldg	10	34x30	1,020	D	8.81	1980		A	8,990	78	1,980		2,000
5 Lean - To	12	14x26	364	C	4.80	1952		A	1,750	95	90		100
6 Barn		30x30	900	D	9.60	1984		A	8,640	68	2,760		2,800
7 Shed		12x26	312	C	7.70	1980		A	2,400	77	550		600
8													
9													
10													
11													

38-030700.0000

TOTAL 130,800

COMMENTS

>>OB Features: 1.4 <Open One Side>  
 Dwelling has an Economic Factor of 115%