

RECOVERY TWP / FT RECOVERY SD

10-16-100-006

Property Class: 111

Neighborhood

008381-A275

Map:

Block:

Card:

Bk: Pg:

38-022400.0100

**GRIESHOP PATRICIA A TRUSTEE**

GRIESHOP PATRICIA A TRUSTEE

2934 WABASH RD

FORT RECOVERY, OH 45846

Created in 2019 From 38-022400.0000 due to Split

**LEGAL INFORMATION**

NW NW

RTS: 001-07-16

Acres:35.0000

**QUALIFIED CREDITS: CAUV:**

**06633: 2021**

	OWNERSHIP	ADDRESS	CITY	STATE	ZIP	DATE	AMOUNT	DEED:CONV#	JS	VALID
1	GRIESHOP PATRICIA A	2934 WABASH RD	FORT RECOVERY	OH	45846	06/12/2020	0	3:QCE : X : 0	<input type="checkbox"/>	<input type="checkbox"/>
2	GRIESHOP PATRICIA A	2518 WABASH RD	FORT RECOVERY	OH	45846	04/23/2019	0	QCE : X : 0	<input type="checkbox"/>	<input type="checkbox"/>
3	GRIESHOP ERIC H & PATRICIA	2518 WABASH RD	FORT RECOVERY	OH	45846	04/23/2019	507,500	WDC : 252	<input type="checkbox"/>	<input checked="" type="checkbox"/>

X:	<input type="checkbox"/> TTO	LISTER: HK	DATE: 07/03/2023	TIME: 12:00:00 AM	<input checked="" type="checkbox"/> LETTER	<input checked="" type="checkbox"/> LETTER REC'D	GIS CODE
----	------------------------------	------------	------------------	-------------------	--	--	----------

STREET/ROAD	TOPOGRAPHY	PU-UTILITIES-PR	NEIGHBORHOOD	INFLUENCE FACTORS	PROPERTY LOCATION
<input type="checkbox"/> PAVED	<input type="checkbox"/> LEVEL	<input type="checkbox"/> WATER	<input type="checkbox"/> IMPROVING	<input type="checkbox"/> A. NO ROAD	2934 WABASH RD
<input type="checkbox"/> GRAVEL	<input type="checkbox"/> HIGH	<input type="checkbox"/> SEWER	<input type="checkbox"/> STATIC	<input type="checkbox"/> B. TOPGRHY	<b>COMMENT</b> TY2022:Net Gen=\$390.50, Other Assessment=\$5.26 DE22 DWLG < 30% COMPL DE23 ADD DWLG @ 65% COMPL NC24 CHK COMPL// PATIO'S
<input type="checkbox"/> DIRT	<input type="checkbox"/> LOW	<input type="checkbox"/> GAS	<input type="checkbox"/> DECLINING	<input type="checkbox"/> C. Ex Front	
<input type="checkbox"/> SIDEWALKS	<input type="checkbox"/> ROLLING	<input type="checkbox"/> ELECTRIC	<input type="checkbox"/> OLD	<input type="checkbox"/> D. QUANTITY	
<input type="checkbox"/> CURBS	<input type="checkbox"/> STANDARD	<input type="checkbox"/> STANDARD	<input type="checkbox"/> STANDARD	<input type="checkbox"/> E. SZ/SHAPE	
				<input type="checkbox"/> F. RESTRICT	
				<input type="checkbox"/> G. WOOD LT	
				<input type="checkbox"/> H. VACANCY	
				<input type="checkbox"/> I. WATER FRONT	
				<input type="checkbox"/> J. OTHER/CDU	

LAND COMPUTATIONS							
LAND TYPE	SIZE	M	RATE	C	INF	M	VALUE C
<b>CR:Crop Land TOTAL</b>	<b>A 29.1010</b>	<b>10,800</b>	<b>2,225</b>			<b>325,460</b>	<b>72,820</b>
0071	A 2.5500	9,150	1,050			23,330	2,680
0022	A 8.8140	11,250	2,540			99,160	22,390
0072	A 8.5030	10,350	1,750			88,010	14,880
0087	A 9.2340	12,450	3,560			114,960	32,870
HS:Home Site:0601	A 1.0000	34,360	34,360			34,360	34,360
RD:Road	A .6270	0	0			0	0
<b>WO:Woods TOTAL</b>	<b>A 4.2720</b>	<b>6,060</b>	<b>1,023</b>			<b>25,410</b>	<b>4,280</b>
0072	A 2.0730	5,360	750			11,110	1,550
Total Acres: 35.0000					TOTAL	385,230	111,460

VALUATION SUMMARY								
VALUE YEAR	2023	2023	2023	2023	2020	2020	2020	2020
REASON FOR CHANGE	CAUV	RAPP	CAUV	NC	CAUV	RAPP	CAUV	MISC
APPRAISED	111,460	385,230	68,840	385,230	34,830	325,070	61,430	319,140
VALUE	IMPR	874,200	874,200	874,200	0	0	0	0
	TOTAL	985,660	1,259,430	943,040	1,259,430	34,830	325,070	61,430
ASSESSED	LAND	39,010	134,830	24,090	134,830	12,190	113,770	21,500
VALUE	IMPR	305,970	305,970	305,970	305,970	0	0	0
	TOTAL	344,980	440,800	330,060	440,800	12,190	113,770	21,500
POTENTIAL RECOUP	2022=3164.34, 2021=3174.28, 2020=3169.35: Total=9507.97							

OCCUPANCY	EXTERIOR	FLOOR	AREA	CONST	VALUE
<input checked="" type="checkbox"/> SF <input type="checkbox"/> DU <input type="checkbox"/> TR	<input type="checkbox"/> WOOD	1	3469	BRK	372,740
<input type="checkbox"/> CONVERSION	<input type="checkbox"/> STUCCO	2ND	1716	BRK	88,490
<b>BUILDING TYPE</b>	<input type="checkbox"/> ALM/VYNL				
<input type="checkbox"/> MOBILE HOME	<input type="checkbox"/> CONC BLK				
<input type="checkbox"/> BI/TR LEVEL	<input type="checkbox"/> METAL				
<input type="checkbox"/> MOD/MAN	<input type="checkbox"/> BRICK				
<input type="checkbox"/>	<input checked="" type="checkbox"/> STONE				

ROOFING	ROOF TYPE
<input type="checkbox"/> METAL	<input type="checkbox"/> GABLE
<input type="checkbox"/> SLT/TLE	<input checked="" type="checkbox"/> HIP
<input checked="" type="checkbox"/> SHINGLES	<input type="checkbox"/> GAMBREL
<input type="checkbox"/> SHAKES	<input type="checkbox"/> MANSARD
<input type="checkbox"/> COMPOSITE	<input type="checkbox"/> FLAT

FLOORS	B	1	2	3	U
CONCRETE	<input type="checkbox"/>	<input type="checkbox"/>	<input type="checkbox"/>	<input type="checkbox"/>	<input type="checkbox"/>
WOOD	<input type="checkbox"/>	<input checked="" type="checkbox"/>	<input checked="" type="checkbox"/>	<input type="checkbox"/>	<input type="checkbox"/>
TILE/COMPO	<input checked="" type="checkbox"/>	<input checked="" type="checkbox"/>	<input checked="" type="checkbox"/>	<input type="checkbox"/>	<input type="checkbox"/>
CARPET	<input checked="" type="checkbox"/>	<input type="checkbox"/>	<input checked="" type="checkbox"/>	<input type="checkbox"/>	<input type="checkbox"/>
INT. FINISH	B	1	2	3	U
PLASTER/DW	<input checked="" type="checkbox"/>	<input checked="" type="checkbox"/>	<input checked="" type="checkbox"/>	<input type="checkbox"/>	<input type="checkbox"/>
PANELING	<input type="checkbox"/>	<input type="checkbox"/>	<input type="checkbox"/>	<input type="checkbox"/>	<input type="checkbox"/>
UNFINISHED	<input type="checkbox"/>	<input type="checkbox"/>	<input type="checkbox"/>	<input type="checkbox"/>	<input type="checkbox"/>
ACCOMMODATIONS					
# OF ROOMS	7	8	4		
BEDROOMS		1	3		
FIREPLACES	1	1			
HEAT & AC	B	1	2	3	U
NO HEAT	<input type="checkbox"/>	<input type="checkbox"/>	<input type="checkbox"/>	<input type="checkbox"/>	<input type="checkbox"/>
CTRL HEAT	<input checked="" type="checkbox"/>	<input checked="" type="checkbox"/>	<input checked="" type="checkbox"/>	<input type="checkbox"/>	<input type="checkbox"/>
HW/STEAM	<input type="checkbox"/>	<input type="checkbox"/>	<input type="checkbox"/>	<input type="checkbox"/>	<input type="checkbox"/>
ELECTRIC	<input type="checkbox"/>	<input type="checkbox"/>	<input type="checkbox"/>	<input type="checkbox"/>	<input type="checkbox"/>
HEAT PUMP	<input checked="" type="checkbox"/>	<input checked="" type="checkbox"/>	<input checked="" type="checkbox"/>	<input type="checkbox"/>	<input type="checkbox"/>
FLR/WALL	<input type="checkbox"/>	<input type="checkbox"/>	<input type="checkbox"/>	<input type="checkbox"/>	<input type="checkbox"/>
STVE/SPCE	<input type="checkbox"/>	<input type="checkbox"/>	<input type="checkbox"/>	<input type="checkbox"/>	<input type="checkbox"/>
GEOHERMAL	<input type="checkbox"/>	<input type="checkbox"/>	<input type="checkbox"/>	<input type="checkbox"/>	<input type="checkbox"/>
OUTSIDE	<input type="checkbox"/>	<input type="checkbox"/>	<input type="checkbox"/>	<input type="checkbox"/>	<input type="checkbox"/>
CTRL A/C	<input checked="" type="checkbox"/>	<input checked="" type="checkbox"/>	<input checked="" type="checkbox"/>	<input type="checkbox"/>	<input type="checkbox"/>
PLUMBING	BASE <input checked="" type="checkbox"/>				
X FULL BATH			1		
X HALF BATH	1	1			
X FIXTURES		3			

BSMT	3469		49,610
<b>SUBTOTAL</b>			510,840
MULTI-FAMILY #	0		0
BUILDING TYPE	100%		0
BSMT FINISH	2,734 S.F.		39,100
FIREPLACE #	2		8,800
HEATING	0 S.F.		0
AIR COND	7,919 S.F.		13,060
PLUMBING #	10		12,100
GARAGES & CARPORTS			50,300
EXTRA FEATURES			28,500
<b>SUBTOTAL</b>			662,700
GRADE FACTOR			205 %
<b>UNADJUSTED VALUE</b>			1,358,540
FACTOR			100 %

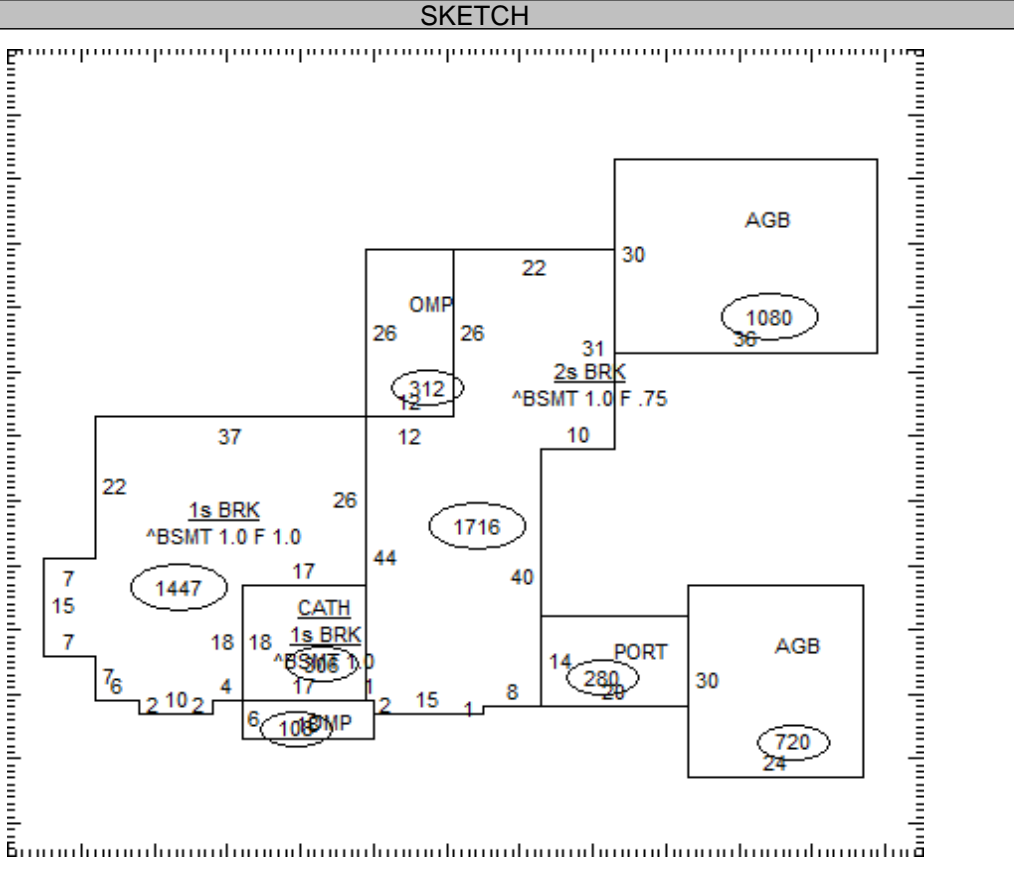

OCCUPANCY	ST.HT	SIZE	AREA	GRADE	PRICE	AGE	REMD	CND	UNADJ VAL	PHYS	PHYS VAL	FUNC	TRUE VAL
DWELLING	2	SK	5,185	AA-		2022		G	1,358,540	1	1,344,950	INC35	874,200
1													
2													
3													
4													
5													
6													
7													
8													
9													
10													
11													

38-022400.0100 TOTAL 874,200

**COMMENTS**

LAUNDRY SINK, 2 EX FIX IN MSTR BATH, ELEVATOR (3 STOPS)  
 Dwelling has an Economic Factor of 100%

RECOVERY TWP / FT RECOVERY SD

10-16-100-006

Property Class: 111

Neighborhood  
008381-A275

Map:  
Block:  
Card:

Bk: Pg:

38-022400.0100

LEGAL INFORMATION

NW NW

QUALIFIED CREDITS: CAUV:  
06633: 2021

RTS: 001-07-16  
Acres:35.0000

GRIESHOP PATRICIA A TRUSTEE  
GRIESHOP PATRICIA A TRUSTEE  
2934 WABASH RD  
FORT RECOVERY, OH 45846  
Created in 2019 From 38-022400.0000 due to Split

	OWNERSHIP	ADDRESS	CITY	STATE	ZIP	DATE	AMOUNT	DEED:CONV#	JS	VALID
1	GRIESHOP PATRICIA A	2934 WABASH RD	FORT RECOVERY	OH	45846	06/12/2020	0	3:QCE : X : 0	<input type="checkbox"/>	<input type="checkbox"/>
2	GRIESHOP PATRICIA A	2518 WABASH RD	FORT RECOVERY	OH	45846	04/23/2019	0	QCE : X : 0	<input type="checkbox"/>	<input type="checkbox"/>
3	GRIESHOP ERIC H & PATRICIA	2518 WABASH RD	FORT RECOVERY	OH	45846	04/23/2019	507,500	WDC : 252	<input type="checkbox"/>	<input checked="" type="checkbox"/>

X:  TTO LISTER: HK DATE: 07/03/2023 TIME: 12:00:00 AM  LETTER  LETTER REC'D GIS CODE

STREET/ROAD	TOPOGRAPHY	PU-UTILITIES-PR	NEIGHBORHOOD	INFLUENCE FACTORS	PROPERTY LOCATION	
<input type="checkbox"/> PAVED <input type="checkbox"/> GRAVEL <input type="checkbox"/> DIRT <input type="checkbox"/> SIDEWALKS <input type="checkbox"/> CURBS	<input type="checkbox"/> LEVEL <input type="checkbox"/> HIGH <input type="checkbox"/> LOW <input type="checkbox"/> ROLLING <input type="checkbox"/> STANDARD	<input type="checkbox"/> WATER <input type="checkbox"/> SEWER <input type="checkbox"/> GAS <input type="checkbox"/> ELECTRIC <input type="checkbox"/> STANDARD	<input type="checkbox"/> IMPROVING <input type="checkbox"/> STATIC <input type="checkbox"/> DECLINING <input type="checkbox"/> OLD <input type="checkbox"/> STANDARD	<input type="checkbox"/> A. NO ROAD <input type="checkbox"/> B. TOPGRHY <input type="checkbox"/> C. Ex Front <input type="checkbox"/> D. QUANTITY <input type="checkbox"/> E. SZ/SHAPE	<input type="checkbox"/> F. RESTRICT <input type="checkbox"/> G. WOOD LT <input type="checkbox"/> H. VACANCY <input type="checkbox"/> I. WATER FRONT <input type="checkbox"/> J. OTHER/CDU	2934 WABASH RD COMMENT

LAND COMPUTATIONS							
LAND TYPE	SIZE	M	RATE	C	INF	M	VALUE C
0087	A 1.2730		7,000	1,670			8,910 2,130
0022	A .9260		5,820	650			5,390 600
Total Acres: 35.0000					TOTAL		385,230 111,460

VALUATION SUMMARY							
VALUE YEAR							
REASON FOR CHANGE							
APPRaised	LAND						
VALUE	IMPR						
	TOTAL						
ASSESSED	LAND						
VALUE	IMPR						
	TOTAL						
POTENTIAL RECOUP	2022=3164.34, 2021=3174.28, 2020=3169.35: Total=9507.97						

<b>OCCUPANCY</b>		<b>EXTERIOR</b>	
<input type="checkbox"/> SF	<input type="checkbox"/> DU	<input type="checkbox"/> TR	<input type="checkbox"/> WOOD
<input type="checkbox"/> CONVERSION		<input type="checkbox"/> STUCCO	
<b>BUILDING TYPE</b>		<input type="checkbox"/> ALM/VYNL	
<input type="checkbox"/> MOBILE HOME		<input type="checkbox"/> CONC BLK	
<input type="checkbox"/> BI/TR LEVEL		<input type="checkbox"/> METAL	
<input type="checkbox"/> MOD/MAN		<input type="checkbox"/> BRICK	
<input type="checkbox"/>		<input type="checkbox"/> STONE	

<b>ROOFING</b>		<b>ROOF TYPE</b>	
<input type="checkbox"/> METAL		<input type="checkbox"/> GABLE	
<input type="checkbox"/> SLT/TLE		<input type="checkbox"/> HIP	
<input type="checkbox"/> SHINGLES		<input type="checkbox"/> GAMBREL	
<input type="checkbox"/> SHAKES		<input type="checkbox"/> MANSARD	
<input type="checkbox"/> COMPOSITE		<input type="checkbox"/> FLAT	

<b>FLOORS</b>		B	1	2	3	U
CONCRETE	<input type="checkbox"/>	<input type="checkbox"/>	<input type="checkbox"/>	<input type="checkbox"/>	<input type="checkbox"/>	<input type="checkbox"/>
WOOD	<input type="checkbox"/>	<input type="checkbox"/>	<input type="checkbox"/>	<input type="checkbox"/>	<input type="checkbox"/>	<input type="checkbox"/>
TILE/COMPO	<input type="checkbox"/>	<input type="checkbox"/>	<input type="checkbox"/>	<input type="checkbox"/>	<input type="checkbox"/>	<input type="checkbox"/>
CARPET	<input type="checkbox"/>	<input type="checkbox"/>	<input type="checkbox"/>	<input type="checkbox"/>	<input type="checkbox"/>	<input type="checkbox"/>

<b>INT. FINISH</b>		B	1	2	3	U
PLASTER/DW	<input type="checkbox"/>	<input type="checkbox"/>	<input type="checkbox"/>	<input type="checkbox"/>	<input type="checkbox"/>	<input type="checkbox"/>
PANELING	<input type="checkbox"/>	<input type="checkbox"/>	<input type="checkbox"/>	<input type="checkbox"/>	<input type="checkbox"/>	<input type="checkbox"/>
UNFINISHED	<input type="checkbox"/>	<input type="checkbox"/>	<input type="checkbox"/>	<input type="checkbox"/>	<input type="checkbox"/>	<input type="checkbox"/>

<b>ACCOMMODATIONS</b>						
# OF ROOMS						
BEDROOMS						
FIREPLACES						
<b>HEAT &amp; AC</b>		B	1	2	3	U

NO HEAT	<input type="checkbox"/>	<input type="checkbox"/>	<input type="checkbox"/>	<input type="checkbox"/>	<input type="checkbox"/>
CTRL HEAT	<input type="checkbox"/>	<input type="checkbox"/>	<input type="checkbox"/>	<input type="checkbox"/>	<input type="checkbox"/>
HW/STEAM	<input type="checkbox"/>	<input type="checkbox"/>	<input type="checkbox"/>	<input type="checkbox"/>	<input type="checkbox"/>
ELECTRIC	<input type="checkbox"/>	<input type="checkbox"/>	<input type="checkbox"/>	<input type="checkbox"/>	<input type="checkbox"/>
HEAT PUMP	<input type="checkbox"/>	<input type="checkbox"/>	<input type="checkbox"/>	<input type="checkbox"/>	<input type="checkbox"/>
FLR/WALL	<input type="checkbox"/>	<input type="checkbox"/>	<input type="checkbox"/>	<input type="checkbox"/>	<input type="checkbox"/>
STVE/SPCE	<input type="checkbox"/>	<input type="checkbox"/>	<input type="checkbox"/>	<input type="checkbox"/>	<input type="checkbox"/>
GEOHERMAL	<input type="checkbox"/>	<input type="checkbox"/>	<input type="checkbox"/>	<input type="checkbox"/>	<input type="checkbox"/>
OUTSIDE	<input type="checkbox"/>	<input type="checkbox"/>	<input type="checkbox"/>	<input type="checkbox"/>	<input type="checkbox"/>
CTRL A/C	<input type="checkbox"/>	<input type="checkbox"/>	<input type="checkbox"/>	<input type="checkbox"/>	<input type="checkbox"/>
<b>PLUMBING</b>		BASE <input type="checkbox"/>			
X FULL BATH					
X HALF BATH					
X FIXTURES					

FLOOR	AREA	CONST	VALUE
<b>SUBTOTAL</b>			0
MULTI-FAMILY #	0		0
BUILDING TYPE	000%		0
BSMT FINISH	0 S.F.		0
FIREPLACE #	0		0
HEATING	0 S.F.		0
AIR COND	0 S.F.		0
PLUMBING #	0		0
GARAGES & CARPORTS			0
EXTRA FEATURES			0
<b>SUBTOTAL</b>			0
GRADE FACTOR			%
<b>UNADJUSTED VALUE</b>			0
<b>FACTOR</b>			%

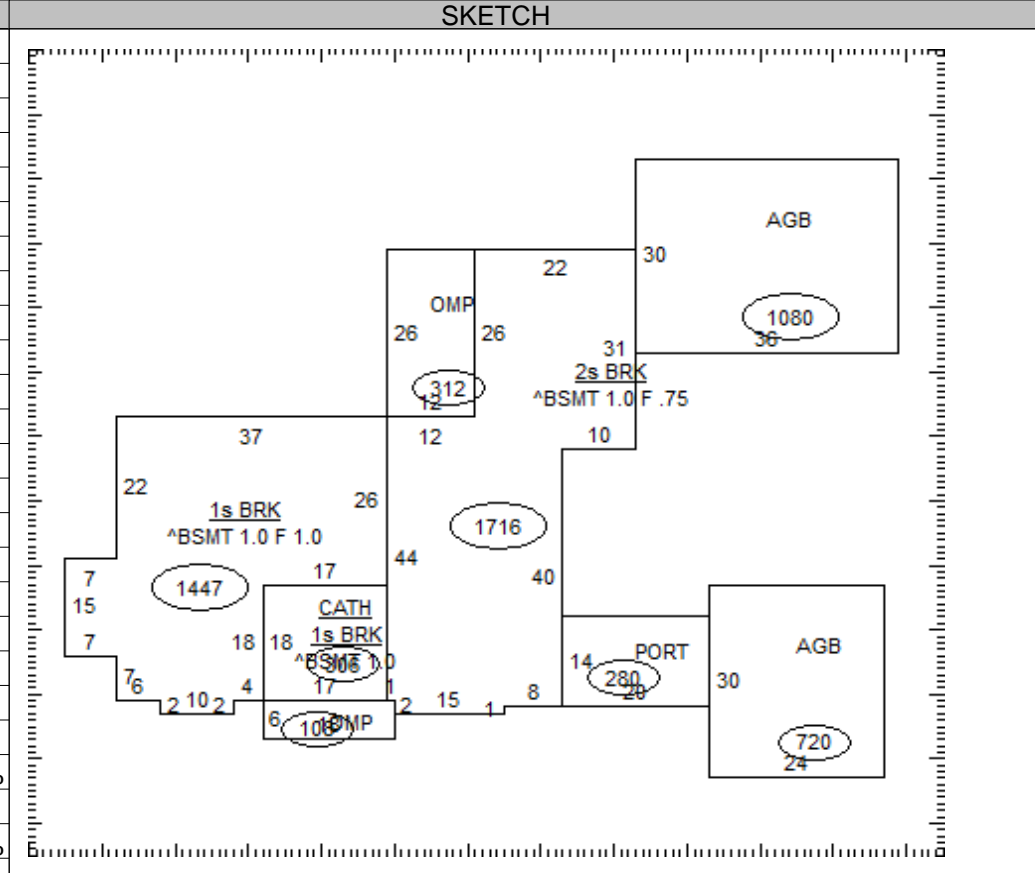

OCCUPANCY	ST.HT	SIZE	AREA	GRADE	PRICE	AGE	REMD	CND	UNADJ VAL	PHYS	PHYS VAL	FUNC	TRUE VAL
DWELLING		SK											
1													
2													
3													
4													
5													
6													
7													
8													
9													
10													
11													

38-022400.0100

TOTAL 0

COMMENTS