

38-005500.0104

KOESTERS DAVID C & CARRIE M

KOESTERS DAVID C & CARRIE M

3725 WABASH RD

FORT RECOVERY, OH 45846

Created in 2006 From 38-005500.0101 due to Split

LEGAL INFORMATION

PT NE SE

R:T:S 001-07-05

Acres:5.5340

	OWNERSHIP	ADDRESS	CITY	STATE	ZIP	DATE	AMOUNT	DEED:CONV#	JS	VALID
1	KOESTERS DAVID C & CARRIE	3725 WABASH RD	FORT RECOVERY	OH	45846	06/20/2011	295,000	WDC : A : 306	<input type="checkbox"/>	<input checked="" type="checkbox"/>
2	YORK BENJAMIN C & LISA M	3719 WABASH RD	FORT RECOVERY	OH	45846	08/07/2006	0	QCE : X : 0	<input type="checkbox"/>	<input type="checkbox"/>
3	JUTTE KENNETH G SR &	3719 WABASH RD	FORT RECOVERY	OH	45846	08/07/2006	0	QCE : X : 0	<input type="checkbox"/>	<input type="checkbox"/>

X: TTO LISTER: HK DATE: 03/04/2021 TIME: 12:00:00 AM LETTER LETTER REC'D GIS CODE

STREET/ROAD TOPOGRAPHY PU-UTILITIES-PR NEIGHBORHOOD INFLUENCE FACTORS PROPERTY LOCATION

PAVED LEVEL WATER IMPROVING A. NO ROAD F. RESTRICT 3725 WABASH RD
 GRAVEL HIGH SEWER STATIC B. TOPGRHY G. WOOD LT
 DIRT LOW GAS DECLINING C. Ex Front H. VACANCY
 SIDEWALKS ROLLING ELECTRIC OLD D. QUANTITY I. WATER FRONT
 CURBS STANDARD STANDARD E. SZ/SHAPE J. OTHER/CDU

COMMENT

TY2022:Net Gen=\$4,144.56, Other Assessment=\$0.90
 DE11 REMOVE 40% INC ON DWLG
 DE17 DESKTOP REVIEW//RMV VAULTED CEILING
 DE20 TTO; ADD BARN @ 75%
 DE21 TTO; RMV INC
 NC24 18 X 25 HOUSE ADDITION

LAND COMPUTATIONS

LAND TYPE	SIZE	M	RATE	C	INF	M	VALUE	C
HS:Home Site	AC:1	34360				34,400	0	
SM:Small Acreage	AC:4.534	7700				34,900	0	
Total Acres: 5.5340						TOTAL	69,300	0

VALUATION SUMMARY

VALUE YEAR	2023	2021	2020	2020	2017	2017	2017	
REASON FOR CHANGE	RAPP	NC	RAPP	NC	RAPP	MISC	MISC	
APPRAISED	69,300	53,100	53,100	44,600	44,600	47,400	47,400	
VALUE	387,500	323,800	299,200	242,200	217,800	182,500	191,600	
	<u>TOTAL</u>	<u>376,900</u>	<u>352,300</u>	<u>286,800</u>	<u>262,400</u>	<u>229,900</u>	<u>239,000</u>	
ASSESSED	24,260	18,590	18,590	15,610	15,610	16,590	16,590	
VALUE	135,630	113,330	104,720	84,770	76,230	63,880	67,060	
	<u>TOTAL</u>	<u>131,920</u>	<u>123,310</u>	<u>100,380</u>	<u>91,840</u>	<u>80,470</u>	<u>83,650</u>	

OCCUPANCY	EXTERIOR	FLOOR	AREA	CONST	VALUE										
<input checked="" type="checkbox"/> SF <input type="checkbox"/> DU <input type="checkbox"/> TR	<input type="checkbox"/> WOOD	1	1664	FR	212,260										
<input type="checkbox"/> CONVERSION	<input type="checkbox"/> STUCCO	2ND	1088	FR	66,620										
BUILDING TYPE	<input checked="" type="checkbox"/> ALM/VYNL														
<input type="checkbox"/> MOBILE HOME	<input type="checkbox"/> CONC BLK														
<input type="checkbox"/> BI/TR LEVEL	<input type="checkbox"/> METAL														
<input type="checkbox"/> MOD/MAN	<input type="checkbox"/> BRICK														
<input type="checkbox"/> _____	<input type="checkbox"/> STONE														
ROOFING	ROOF TYPE														
<input type="checkbox"/> METAL	<input checked="" type="checkbox"/> GABLE														
<input type="checkbox"/> SLT/TLE	<input type="checkbox"/> HIP														
<input checked="" type="checkbox"/> SHINGLES	<input type="checkbox"/> GAMBREL														
<input type="checkbox"/> SHAKES	<input type="checkbox"/> MANSARD														
<input type="checkbox"/> COMPOSITE	<input type="checkbox"/> FLAT														
FLOORS	B 1 2 3 U	BSMT	1088		15,560										
CONCRETE	<input checked="" type="checkbox"/> <input type="checkbox"/> <input type="checkbox"/> <input type="checkbox"/> <input type="checkbox"/>	SUBTOTAL			294,440										
WOOD	<input type="checkbox"/> <input type="checkbox"/> <input type="checkbox"/> <input type="checkbox"/> <input type="checkbox"/>	MULTI-FAMILY #	0		0										
TILE/COMPO	<input type="checkbox"/> <input checked="" type="checkbox"/> <input type="checkbox"/> <input type="checkbox"/> <input type="checkbox"/>	BUILDING TYPE	100%		0										
CARPET	<input type="checkbox"/> <input checked="" type="checkbox"/> <input type="checkbox"/> <input type="checkbox"/> <input type="checkbox"/>	BSMT FINISH	0 S.F.		0										
INT. FINISH	B 1 2 3 U	FIREPLACE #	0		0										
PLASTER/DW	<input type="checkbox"/> <input checked="" type="checkbox"/> <input type="checkbox"/> <input type="checkbox"/> <input type="checkbox"/>	HEATING	0 S.F.		0										
PANELING	<input type="checkbox"/> <input type="checkbox"/> <input type="checkbox"/> <input type="checkbox"/> <input type="checkbox"/>	AIR COND	2,752 S.F.		4,550										
UNFINISHED	<input checked="" type="checkbox"/> <input checked="" type="checkbox"/> <input type="checkbox"/> <input type="checkbox"/> <input type="checkbox"/>	PLUMBING #	8		9,680										
ACCOMMODATIONS		GARAGES & CARPORTS			22,100										
# OF ROOMS		EXTRA FEATURES			3,300										
BEDROOMS		SUBTOTAL			334,070										
FIREPLACES		GRADE FACTOR			100 %										
HEAT & AC		UNADJUSTED VALUE			334,070										
NO HEAT	<input type="checkbox"/> <input type="checkbox"/> <input type="checkbox"/> <input type="checkbox"/> <input type="checkbox"/>	FACTOR			100 %										
CTRL HEAT	<input type="checkbox"/> <input checked="" type="checkbox"/> <input checked="" type="checkbox"/> <input type="checkbox"/> <input type="checkbox"/>	OCCUPANCY	ST.HT	SIZE	AREA	GRADE	PRICE	AGE	REMD	CND	UNADJ VAL	PHYS	PHYS VAL	FUNC	TRUE VAL
HW/STEAM	<input type="checkbox"/> <input type="checkbox"/> <input type="checkbox"/> <input type="checkbox"/> <input type="checkbox"/>	DWELLING	2	SK	2,752	C		2007		A	334,070	15	283,960		326,600
ELECTRIC	<input type="checkbox"/> <input type="checkbox"/> <input type="checkbox"/> <input type="checkbox"/> <input type="checkbox"/>	1 Barn	20	30x64	1,920	C	12.00	2019		A	23,040	4	22,120		22,100
HEAT PUMP	<input type="checkbox"/> <input type="checkbox"/> <input type="checkbox"/> <input type="checkbox"/> <input type="checkbox"/>	2 Gar - Frame	10	30x40	1,200	C	26.25	2019		A	31,500	4	30,240		30,200
FLR/WALL	<input type="checkbox"/> <input type="checkbox"/> <input type="checkbox"/> <input type="checkbox"/> <input type="checkbox"/>	3 OFP		0x0	560	C	16.04	2019		A	8,980	4	8,620		8,600
STVE/SPCE	<input type="checkbox"/> <input type="checkbox"/> <input type="checkbox"/> <input type="checkbox"/> <input type="checkbox"/>	4													
GEOHERMAL	<input type="checkbox"/> <input type="checkbox"/> <input type="checkbox"/> <input type="checkbox"/> <input type="checkbox"/>	5													
OUTSIDE	<input type="checkbox"/> <input type="checkbox"/> <input type="checkbox"/> <input type="checkbox"/> <input type="checkbox"/>	6													
CTRL A/C	<input type="checkbox"/> <input checked="" type="checkbox"/> <input checked="" type="checkbox"/> <input type="checkbox"/> <input type="checkbox"/>	7													
PLUMBING	BASE <input checked="" type="checkbox"/>	8													
X FULL BATH		9													
X HALF BATH		10													
X FIXTURES		11													

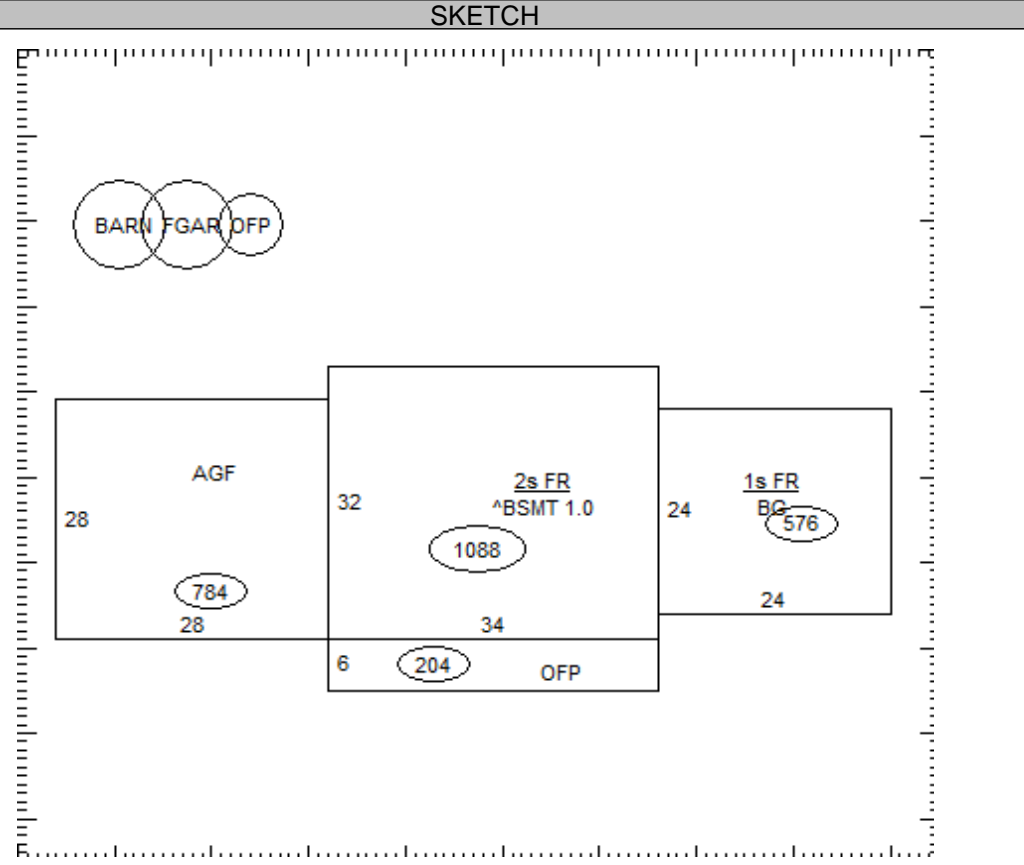

38-005500.0104

TOTAL 387,500

COMMENTS

>>OB Features: 1.2 <Unfinished Loft>
 Dwelling has an Economic Factor of 115% (Rollback Basis=\$361,000)



38-005500.0104

KOESTERS DAVID C & CARRIE M
KOESTERS DAVID C & CARRIE M
3725 WABASH RD
FORT RECOVERY, OH 45846
Created in 2006 From 38-005500.0101 due to Split

LEGAL INFORMATION
PT NE SE

R:T:S 001-07-05
Acres:5.5340

	OWNERSHIP	ADDRESS	CITY	STATE	ZIP	DATE	AMOUNT	DEED:CONV#	JS	VALID
1	YORK BENJAMIN C & LISA M	3719 WABASH RD	FORT RECOVERY	OH	45846	01/17/2006	10,000	WDC : A : 45	<input type="checkbox"/>	<input type="checkbox"/>
2							0	0	<input type="checkbox"/>	<input type="checkbox"/>
3							0	0	<input type="checkbox"/>	<input type="checkbox"/>

X: TTO LISTER: HK DATE: 03/04/2021 TIME: 12:00:00 AM LETTER LETTER REC'D GIS CODE

STREET/ROAD	TOPOGRAPHY	PU-UTILITIES-PR	NEIGHBORHOOD	INFLUENCE FACTORS	PROPERTY LOCATION	
<input type="checkbox"/> PAVED <input type="checkbox"/> GRAVEL <input type="checkbox"/> DIRT <input type="checkbox"/> SIDEWALKS <input type="checkbox"/> CURBS	<input type="checkbox"/> LEVEL <input type="checkbox"/> HIGH <input type="checkbox"/> LOW <input type="checkbox"/> ROLLING <input type="checkbox"/> STANDARD	<input type="checkbox"/> WATER <input type="checkbox"/> SEWER <input type="checkbox"/> GAS <input type="checkbox"/> ELECTRIC <input type="checkbox"/> STANDARD	<input type="checkbox"/> IMPROVING <input type="checkbox"/> STATIC <input type="checkbox"/> DECLINING <input type="checkbox"/> OLD <input type="checkbox"/> STANDARD	<input type="checkbox"/> A. NO ROAD <input type="checkbox"/> B. TOPGRHY <input type="checkbox"/> C. Ex Front <input type="checkbox"/> D. QUANTITY <input type="checkbox"/> E. SZ/SHAPE	<input type="checkbox"/> F. RESTRICT <input type="checkbox"/> G. WOOD LT <input type="checkbox"/> H. VACANCY <input type="checkbox"/> I. WATER FRONT <input type="checkbox"/> J. OTHER/CDU	3725 WABASH RD COMMENT

LAND COMPUTATIONS

LAND TYPE	SIZE	M	RATE	C	INF	M	VALUE	C
Total Acres: 5.5340					TOTAL		69,300	0

VALUATION SUMMARY

VALUE YEAR	REASON FOR CHANGE	APPRaised	IMPR	TOTAL	ASSESSED	IMPR	TOTAL

OCCUPANCY		EXTERIOR		FLOOR	AREA	CONST	VALUE
<input type="checkbox"/> SF	<input type="checkbox"/> DU	<input type="checkbox"/> TR	<input type="checkbox"/> WOOD				
<input type="checkbox"/> CONVERSION			<input type="checkbox"/> STUCCO				
BUILDING TYPE			<input type="checkbox"/> ALM/VYNL				
<input type="checkbox"/> MOBILE HOME			<input type="checkbox"/> CONC BLK				
<input type="checkbox"/> BI/TR LEVEL			<input type="checkbox"/> METAL				
<input type="checkbox"/> MOD/MAN			<input type="checkbox"/> BRICK				
<input type="checkbox"/>			<input type="checkbox"/> STONE				

ROOFING		ROOF TYPE	
<input type="checkbox"/> METAL	<input type="checkbox"/> SLT/TLE	<input type="checkbox"/> SHINGLES	<input type="checkbox"/> SHAKES
<input type="checkbox"/> COMPOSITE	<input type="checkbox"/> GABLE	<input type="checkbox"/> HIP	<input type="checkbox"/> GAMBREL
	<input type="checkbox"/> MANSARD	<input type="checkbox"/> FLAT	

FLOORS		B	1	2	3	U	SUBTOTAL	0
CONCRETE		<input type="checkbox"/>	<input type="checkbox"/>	<input type="checkbox"/>	<input type="checkbox"/>	<input type="checkbox"/>	MULTI-FAMILY #	0
WOOD		<input type="checkbox"/>	<input type="checkbox"/>	<input type="checkbox"/>	<input type="checkbox"/>	<input type="checkbox"/>	BUILDING TYPE	000%
TILE/COMPO		<input type="checkbox"/>	<input type="checkbox"/>	<input type="checkbox"/>	<input type="checkbox"/>	<input type="checkbox"/>	BSMT FINISH	0 S.F.
CARPET		<input type="checkbox"/>	<input type="checkbox"/>	<input type="checkbox"/>	<input type="checkbox"/>	<input type="checkbox"/>	FIREPLACE #	0
INT. FINISH		B	1	2	3	U	HEATING	0 S.F.
PLASTER/DW		<input type="checkbox"/>	<input type="checkbox"/>	<input type="checkbox"/>	<input type="checkbox"/>	<input type="checkbox"/>	AIR COND	0 S.F.
PANELING		<input type="checkbox"/>	<input type="checkbox"/>	<input type="checkbox"/>	<input type="checkbox"/>	<input type="checkbox"/>	PLUMBING #	0
UNFINISHED		<input type="checkbox"/>	<input type="checkbox"/>	<input type="checkbox"/>	<input type="checkbox"/>	<input type="checkbox"/>	GARAGES & CARPORTS	0
ACCOMMODATIONS							EXTRA FEATURES	0
# OF ROOMS							SUBTOTAL	0
BEDROOMS							GRADE FACTOR	%
FIREPLACES							UNADJUSTED VALUE	0
HEAT & AC		B	1	2	3	U	FACTOR	%
NO HEAT		<input type="checkbox"/>	<input type="checkbox"/>	<input type="checkbox"/>	<input type="checkbox"/>	<input type="checkbox"/>		
CTRL HEAT		<input type="checkbox"/>	<input type="checkbox"/>	<input type="checkbox"/>	<input type="checkbox"/>	<input type="checkbox"/>		
HW/STEAM		<input type="checkbox"/>	<input type="checkbox"/>	<input type="checkbox"/>	<input type="checkbox"/>	<input type="checkbox"/>		
ELECTRIC		<input type="checkbox"/>	<input type="checkbox"/>	<input type="checkbox"/>	<input type="checkbox"/>	<input type="checkbox"/>		
HEAT PUMP		<input type="checkbox"/>	<input type="checkbox"/>	<input type="checkbox"/>	<input type="checkbox"/>	<input type="checkbox"/>		
FLR/WALL		<input type="checkbox"/>	<input type="checkbox"/>	<input type="checkbox"/>	<input type="checkbox"/>	<input type="checkbox"/>		
STVE/SPCE		<input type="checkbox"/>	<input type="checkbox"/>	<input type="checkbox"/>	<input type="checkbox"/>	<input type="checkbox"/>		
GEOTHERMAL		<input type="checkbox"/>	<input type="checkbox"/>	<input type="checkbox"/>	<input type="checkbox"/>	<input type="checkbox"/>		
OUTSIDE		<input type="checkbox"/>	<input type="checkbox"/>	<input type="checkbox"/>	<input type="checkbox"/>	<input type="checkbox"/>		
CTRL A/C		<input type="checkbox"/>	<input type="checkbox"/>	<input type="checkbox"/>	<input type="checkbox"/>	<input type="checkbox"/>		
PLUMBING			BASE			<input type="checkbox"/>		
X FULL BATH								
X HALF BATH								
X FIXTURES								

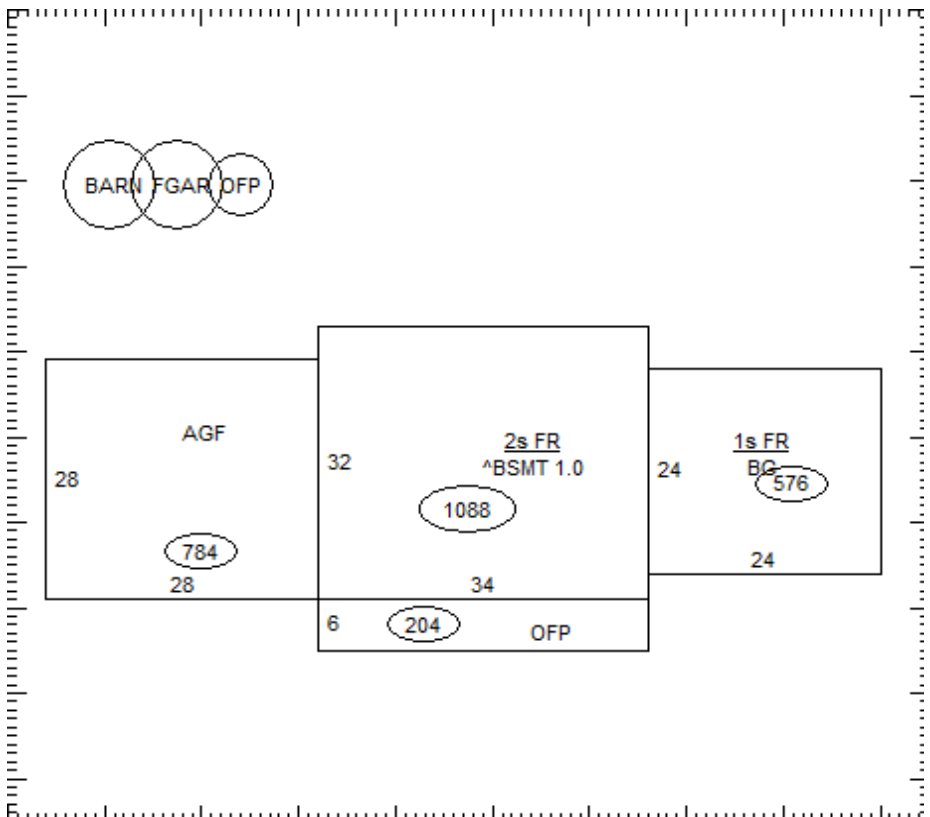

OCCUPANCY	ST.HT	SIZE	AREA	GRADE	PRICE	AGE	REMD	CND	UNADJ VAL	PHYS	PHYS VAL	FUNC	TRUE VAL
DWELLING		SK											
1													
2													
3													
4													
5													
6													
7													
8													
9													
10													
11													

38-005500.0104

TOTAL 0

COMMENTS													