

MARION TWP / MARION SD

12-28-300-009

31-068400.0100

SCHAEFER BENJAMIN M & CHLOE R
SCHAEFER BENJAMIN M & CHLOE R
7181 MINSTER FT RECOVERY RD
MARIA STEIN, OH 45860

LEGAL INFORMATION
PT SE SW

RTS: 003-07-28
Acres:1.6740

	OWNERSHIP	ADDRESS	CITY	STATE	ZIP	DATE	AMOUNT	DEED:CONV#	JS	VALID
1	SCHAEFER BENJAMIN M &	7181 MINSTER FT	MARIA STEIN	OH	45860	01/10/2020	310,000	WDC : 24	<input type="checkbox"/>	<input checked="" type="checkbox"/>
2	POEPELPMAN DANIEL LEE	7181 FT RECOVERY	MARIA STEIN	OH	45860	02/08/2010	0	QCE : X : 0	<input type="checkbox"/>	<input type="checkbox"/>
3	POEPELPMAN DANIEL LEE &	7181 FT RECOVERY	MARIA STEIN	OH	45860	11/30/1998	96,000	: A : 0	<input type="checkbox"/>	<input checked="" type="checkbox"/>

X: TTO LISTER: JO DATE: 02/08/2005 TIME: 12:00:00 AM LETTER LETTER REC'D GIS CODE

STREET/ROAD	TOPOGRAPHY	PU-UTILITIES-PR	NEIGHBORHOOD	INFLUENCE FACTORS	PROPERTY LOCATION	
<input checked="" type="checkbox"/> PAVED <input type="checkbox"/> GRAVEL <input type="checkbox"/> DIRT <input type="checkbox"/> SIDEWALKS <input type="checkbox"/> CURBS	<input checked="" type="checkbox"/> LEVEL <input type="checkbox"/> HIGH <input type="checkbox"/> LOW <input type="checkbox"/> ROLLING <input type="checkbox"/> STANDARD	<input type="checkbox"/> WATER <input type="checkbox"/> SEWER <input type="checkbox"/> GAS <input type="checkbox"/> ELECTRIC <input checked="" type="checkbox"/> STANDARD	<input type="checkbox"/> IMPROVING <input checked="" type="checkbox"/> STATIC <input type="checkbox"/> DECLINING <input type="checkbox"/> OLD <input type="checkbox"/> STANDARD	<input type="checkbox"/> A. NO ROAD <input type="checkbox"/> B. TOPGRHY <input type="checkbox"/> C. Ex Front <input type="checkbox"/> D. QUANTITY <input type="checkbox"/> E. SZ/SHAPE	<input type="checkbox"/> F. RESTRICT <input type="checkbox"/> G. WOOD LT <input type="checkbox"/> H. VACANCY <input type="checkbox"/> I. WATER FRONT <input type="checkbox"/> J. OTHER/CDU	7181 FT RECOVERY MINSTER RD, MARIA STEIN COMMENT TY2022:Net Gen=\$2,362.12, Other Assessment=\$2.00 DE09 PER DATA MAILER CORRECTED OUTBLDG SIZES & LOCATION DE17 DESKTOP RVW CHG: COR EX FEATURES

LAND COMPUTATIONS						
LAND TYPE	SIZE	M	RATE	C	INF	M VALUE C
HS:Home Site	AC:1	30900				30,900 0
SM:Small Acreage	AC:0.674	8500				5,700 0
Total Acres: 1.6740					TOTAL	36,600 0

VALUATION SUMMARY					
VALUE YEAR	2023	2020	2017	2017	
REASON FOR CHANGE	RAPP	RAPP	RAPP	MISC	
APPRaised	<u>LAND</u>	36,600	22,700	21,200	24,500
VALUE	<u>IMPR</u>	194,100	145,800	124,900	88,500
	<u>TOTAL</u>	230,700	168,500	146,100	113,000
ASSESSED	<u>LAND</u>	12,810	7,950	7,420	8,580
VALUE	<u>IMPR</u>	67,940	51,030	43,720	30,980
	<u>TOTAL</u>	80,750	58,980	51,140	39,560

<input type="checkbox"/> SF <input type="checkbox"/> DU <input type="checkbox"/> TR	<input checked="" type="checkbox"/> WOOD
<input type="checkbox"/> CONVERSION	<input type="checkbox"/> STUCCO
BUILDING TYPE	<input type="checkbox"/> ALM/VYNL
<input type="checkbox"/> MOBILE HOME	<input type="checkbox"/> CONC BLK
<input type="checkbox"/> BI/TR LEVEL	<input type="checkbox"/> METAL
<input type="checkbox"/> MOD/MAN	<input type="checkbox"/> BRICK
<input type="checkbox"/>	<input type="checkbox"/> STONE

ROOFING	ROOF TYPE
<input type="checkbox"/> METAL	<input checked="" type="checkbox"/> GABLE
<input type="checkbox"/> SLT/TLE	<input type="checkbox"/> HIP
<input checked="" type="checkbox"/> SHINGLES	<input type="checkbox"/> GAMBREL
<input type="checkbox"/> SHAKES	<input type="checkbox"/> MANSARD
<input type="checkbox"/> COMPOSITE	<input type="checkbox"/> FLAT

FLOORS	B	1	2	3	U
CONCRETE	<input checked="" type="checkbox"/>	<input type="checkbox"/>	<input type="checkbox"/>	<input type="checkbox"/>	<input type="checkbox"/>
WOOD	<input type="checkbox"/>	<input checked="" type="checkbox"/>	<input checked="" type="checkbox"/>	<input type="checkbox"/>	<input type="checkbox"/>
TILE/COMPO	<input type="checkbox"/>	<input type="checkbox"/>	<input type="checkbox"/>	<input type="checkbox"/>	<input type="checkbox"/>
CARPET	<input type="checkbox"/>	<input type="checkbox"/>	<input type="checkbox"/>	<input type="checkbox"/>	<input type="checkbox"/>
INT. FINISH	B	1	2	3	U
PLASTER/DW	<input type="checkbox"/>	<input checked="" type="checkbox"/>	<input checked="" type="checkbox"/>	<input type="checkbox"/>	<input type="checkbox"/>
PANELING	<input type="checkbox"/>	<input type="checkbox"/>	<input type="checkbox"/>	<input type="checkbox"/>	<input type="checkbox"/>
UNFINISHED	<input type="checkbox"/>	<input type="checkbox"/>	<input type="checkbox"/>	<input type="checkbox"/>	<input type="checkbox"/>
ACCOMMODATIONS					
# OF ROOMS		4	4		
BEDROOMS			4		
FIREPLACES					
HEAT & AC	B	1	2	3	U
NO HEAT	<input type="checkbox"/>	<input type="checkbox"/>	<input type="checkbox"/>	<input type="checkbox"/>	<input type="checkbox"/>
CTRL HEAT	<input checked="" type="checkbox"/>	<input checked="" type="checkbox"/>	<input checked="" type="checkbox"/>	<input type="checkbox"/>	<input type="checkbox"/>
HW/STEAM	<input type="checkbox"/>	<input type="checkbox"/>	<input type="checkbox"/>	<input type="checkbox"/>	<input type="checkbox"/>
ELECTRIC	<input type="checkbox"/>	<input type="checkbox"/>	<input type="checkbox"/>	<input type="checkbox"/>	<input type="checkbox"/>
HEAT PUMP	<input type="checkbox"/>	<input type="checkbox"/>	<input type="checkbox"/>	<input type="checkbox"/>	<input type="checkbox"/>
FLR/WALL	<input type="checkbox"/>	<input type="checkbox"/>	<input type="checkbox"/>	<input type="checkbox"/>	<input type="checkbox"/>
STVE/SPCE	<input type="checkbox"/>	<input type="checkbox"/>	<input type="checkbox"/>	<input type="checkbox"/>	<input type="checkbox"/>
GEOHERMAL	<input type="checkbox"/>	<input type="checkbox"/>	<input type="checkbox"/>	<input type="checkbox"/>	<input type="checkbox"/>
OUTSIDE	<input type="checkbox"/>	<input type="checkbox"/>	<input type="checkbox"/>	<input type="checkbox"/>	<input type="checkbox"/>
CTRL A/C	<input type="checkbox"/>	<input type="checkbox"/>	<input type="checkbox"/>	<input type="checkbox"/>	<input type="checkbox"/>
PLUMBING	BASE <input checked="" type="checkbox"/>				
X FULL BATH					
X HALF BATH					
X FIXTURES					

FLOOR	AREA	CONST	VALUE
1	1224	FR	181,210
.5	612	FR	56,180
BSMT	1224		17,500
SUBTOTAL			254,890
MULTI-FAMILY #	0		0
BUILDING TYPE	100%		0
BSMT FINISH	306 S.F.		4,380
FIREPLACE #	0		0
HEATING	0 S.F.		0
AIR COND	0 S.F.		0
PLUMBING #	0		0
GARAGES & CARPORTS			0
EXTRA FEATURES			6,500
SUBTOTAL			265,770
GRADE FACTOR			95 %
UNADJUSTED VALUE			252,480
FACTOR			100 %

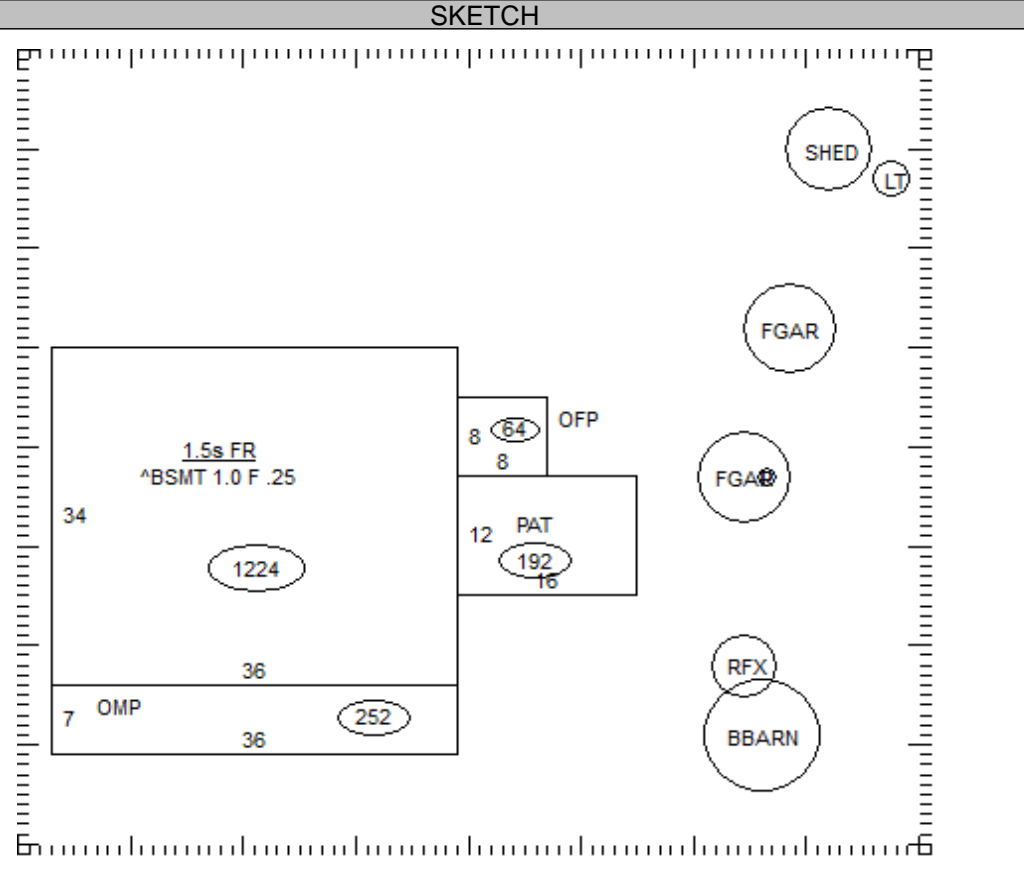

OCCUPANCY	ST.HT	SIZE	AREA	GRADE	PRICE	AGE	REMD	CND	UNADJ VAL	PHYS	PHYS VAL	FUNC	TRUE VAL
DWELLING	1.5	SK	1,836	C-		1950		A	252,480	45	138,860		187,500
1 Barn-Bank	16	45x58	2,610	D	12.00	1900		A	31,320	95	1,570	DFLT50	800
2 Rfx	10	45x8	360	C	8.91	1990		A	3,210	57	1,380		1,400
3 Gar - Frame	7	20x32	640	D	18.96	1960		A	12,130	90	1,210		1,200
4 Lean - To	7	16x16	256	C	4.80	1960		F	1,230	90	120		100
5 Shed	8	20x49	980	C	6.60	1957		F	6,470	90	650		700
6 Gar - Frame	7	20x28	560	C	23.70	1966		A	13,270	85	1,990		2,000
7 Patio		18x26	468	C	4.05	1980		A	1,900	77	440		400
8													
9													
10													
11													

31-068400.0100 TOTAL 194,100

COMMENTS

Dwelling has an Economic Factor of 135% (Rollback Basis=\$220,400)