

31-043200.0000

WINNER NANCEE ETAL

WINNER NANCEE ETAL

7243 MERCER DARKE COUNTY LINE RD

MARIA STEIN, OH 45860

LEGAL INFORMATION

TANGEMAN ADDITION

IN LOT 2

	OWNERSHIP	ADDRESS	CITY	STATE	ZIP	DATE	AMOUNT	DEED:CONV#	JS	VALID
1	WINNER NANCEE ETAL	7243 MERCER DARKE	MARIA STEIN	OH	45860	07/10/2015	0	QCE : X : 0	<input type="checkbox"/>	<input type="checkbox"/>
2	WINNER NANCEE ETAL	7243 MERCER DARKE CO	MARIA STEIN	OH	45860-0063	06/24/2009	0	QCE : X : 0	<input type="checkbox"/>	<input type="checkbox"/>
3	WINNER NANCEE ETAL	2040 NORTHVIEW DR PO	MARIA STEIN	OH	45860	04/23/2004	150,000	WDC : A : 0	<input type="checkbox"/>	<input checked="" type="checkbox"/>

X: TTO LISTER: NS DATE: 12/08/2004 TIME: 12:00:00 AM LETTER LETTER REC'D GIS CODE

STREET/ROAD	TOPOGRAPHY	PU-UTILITIES-PR	NEIGHBORHOOD	INFLUENCE FACTORS	PROPERTY LOCATION
<input checked="" type="checkbox"/> PAVED	<input checked="" type="checkbox"/> LEVEL	<input type="checkbox"/> WATER	<input checked="" type="checkbox"/> IMPROVING	<input type="checkbox"/> A. NO ROAD	2040 NORTHVIEW DR, MARIA STEIN
<input type="checkbox"/> GRAVEL	<input type="checkbox"/> HIGH	<input type="checkbox"/> SEWER	<input checked="" type="checkbox"/> STATIC	<input type="checkbox"/> B. TOPGRHY	COMMENT
<input type="checkbox"/> DIRT	<input type="checkbox"/> LOW	<input checked="" type="checkbox"/> GAS	<input type="checkbox"/> DECLINING	<input type="checkbox"/> C. Ex Front	TY2022:Net Gen=\$2,463.12, Other
<input type="checkbox"/> SIDEWALKS	<input type="checkbox"/> ROLLING	<input checked="" type="checkbox"/> ELECTRIC	<input type="checkbox"/> OLD	<input type="checkbox"/> D. QUANTITY	Assessment=\$56.00
<input type="checkbox"/> CURBS	<input type="checkbox"/> STANDARD	<input type="checkbox"/> STANDARD	<input type="checkbox"/> STANDARD	<input type="checkbox"/> E. SZ/SHAPE	6/24/09 OWNERS WINNER, NANCEE; EVERMAN, MARIE; TANGEMAN JERALD & KAREN TRUSTEES; TANGEMAN JAMES & ANGELA TRUSTEES; TANGEMAN JON & TANGEMAN SCOTT
				<input type="checkbox"/> F. RESTRICT	
				<input type="checkbox"/> G. WOOD LT	
				<input type="checkbox"/> H. VACANCY	
				<input type="checkbox"/> I. WATER FRONT	
				<input type="checkbox"/> J. OTHER/CDU	

LAND COMPUTATIONS

LAND TYPE	SIZE	M	RATE	C	INF	M	VALUE	C
F:Front	F124 D164	ST270	DP104	ADJ281			34,800	0
TOTAL							34,800	0

VALUATION SUMMARY

VALUE YEAR	2023	2020	2017				
REASON FOR CHANGE	RAPP	RAPP	RAPP				
APPRAISED VALUE	LAND 34,800	22,400	16,700				
	IMPR 229,100	149,300	124,600				
	TOTAL 263,900	171,700	141,300				
ASSESSED VALUE	LAND 12,180	7,840	5,850				
	IMPR 80,190	52,260	43,610				
	TOTAL 92,370	60,100	49,460				

OCCUPANCY	EXTERIOR	FLOOR	AREA	CONST	VALUE	
<input checked="" type="checkbox"/> SF <input type="checkbox"/> DU <input type="checkbox"/> TR	<input checked="" type="checkbox"/> WOOD	1	1393	FR	195,730	
<input type="checkbox"/> CONVERSION	<input type="checkbox"/> STUCCO	.25	348	FR	44,630	
BUILDING TYPE						
<input type="checkbox"/> MOBILE HOME	<input checked="" type="checkbox"/> ALM/VYNL					
<input type="checkbox"/> BI/TR LEVEL	<input type="checkbox"/> CONC BLK					
<input type="checkbox"/> MOD/MAN	<input type="checkbox"/> METAL					
<input type="checkbox"/>	<input type="checkbox"/> BRICK					
	<input type="checkbox"/> STONE					
ROOFING						
ROOF TYPE						
<input type="checkbox"/> METAL	<input checked="" type="checkbox"/> GABLE					
<input type="checkbox"/> SLT/TLE	<input type="checkbox"/> HIP					
<input checked="" type="checkbox"/> SHINGLES	<input type="checkbox"/> GAMBREL					
<input type="checkbox"/> SHAKES	<input type="checkbox"/> MANSARD					
<input type="checkbox"/> COMPOSITE	<input type="checkbox"/> FLAT					
FLOORS		B	1	2	3	U
CONCRETE	<input checked="" type="checkbox"/>	<input type="checkbox"/>	<input type="checkbox"/>	<input type="checkbox"/>	<input type="checkbox"/>	<input type="checkbox"/>
WOOD	<input type="checkbox"/>	<input checked="" type="checkbox"/>	<input checked="" type="checkbox"/>	<input type="checkbox"/>	<input type="checkbox"/>	<input type="checkbox"/>
TILE/COMPO	<input type="checkbox"/>	<input type="checkbox"/>	<input type="checkbox"/>	<input type="checkbox"/>	<input type="checkbox"/>	<input type="checkbox"/>
CARPET	<input type="checkbox"/>	<input checked="" type="checkbox"/>	<input checked="" type="checkbox"/>	<input type="checkbox"/>	<input type="checkbox"/>	<input type="checkbox"/>
INT. FINISH		B	1	2	3	U
PLASTER/DW	<input type="checkbox"/>	<input checked="" type="checkbox"/>	<input checked="" type="checkbox"/>	<input type="checkbox"/>	<input type="checkbox"/>	<input type="checkbox"/>
PANELING	<input type="checkbox"/>	<input type="checkbox"/>	<input type="checkbox"/>	<input type="checkbox"/>	<input type="checkbox"/>	<input type="checkbox"/>
UNFINISHED	<input checked="" type="checkbox"/>	<input type="checkbox"/>	<input type="checkbox"/>	<input type="checkbox"/>	<input type="checkbox"/>	<input type="checkbox"/>
ACCOMMODATIONS						
# OF ROOMS		5	2			
BEDROOMS		1	2			
FIREPLACES		1				
HEAT & AC		B	1	2	3	U
NO HEAT	<input type="checkbox"/>	<input type="checkbox"/>	<input type="checkbox"/>	<input type="checkbox"/>	<input type="checkbox"/>	<input type="checkbox"/>
CTRL HEAT	<input type="checkbox"/>	<input checked="" type="checkbox"/>	<input checked="" type="checkbox"/>	<input type="checkbox"/>	<input type="checkbox"/>	<input type="checkbox"/>
HW/STEAM	<input type="checkbox"/>	<input type="checkbox"/>	<input type="checkbox"/>	<input type="checkbox"/>	<input type="checkbox"/>	<input type="checkbox"/>
ELECTRIC	<input type="checkbox"/>	<input type="checkbox"/>	<input type="checkbox"/>	<input type="checkbox"/>	<input type="checkbox"/>	<input type="checkbox"/>
HEAT PUMP	<input type="checkbox"/>	<input type="checkbox"/>	<input type="checkbox"/>	<input type="checkbox"/>	<input type="checkbox"/>	<input type="checkbox"/>
FLR/WALL	<input type="checkbox"/>	<input type="checkbox"/>	<input type="checkbox"/>	<input type="checkbox"/>	<input type="checkbox"/>	<input type="checkbox"/>
STVE/SPCE	<input type="checkbox"/>	<input type="checkbox"/>	<input type="checkbox"/>	<input type="checkbox"/>	<input type="checkbox"/>	<input type="checkbox"/>
GEO THERMAL	<input type="checkbox"/>	<input type="checkbox"/>	<input type="checkbox"/>	<input type="checkbox"/>	<input type="checkbox"/>	<input type="checkbox"/>
OUTSIDE	<input type="checkbox"/>	<input type="checkbox"/>	<input type="checkbox"/>	<input type="checkbox"/>	<input type="checkbox"/>	<input type="checkbox"/>
CTRL A/C	<input type="checkbox"/>	<input checked="" type="checkbox"/>	<input checked="" type="checkbox"/>	<input type="checkbox"/>	<input type="checkbox"/>	<input type="checkbox"/>
PLUMBING		BASE <input checked="" type="checkbox"/>				
X FULL BATH						
X HALF BATH		1				
X FIXTURES						
		BSMT	1408		20,130	
SUBTOTAL					260,490	
MULTI-FAMILY #		0			0	
BUILDING TYPE		100%			0	
BSMT FINISH		0 S.F.			0	
FIREPLACE #		1			4,400	
HEATING		0 S.F.			0	
AIR COND		1,741 S.F.			2,870	
PLUMBING #		2			2,420	
GARAGES & CARPORTS					17,800	
EXTRA FEATURES					4,600	
SUBTOTAL					292,580	
GRADE FACTOR					100 %	
UNADJUSTED VALUE					292,580	
FACTOR					100 %	

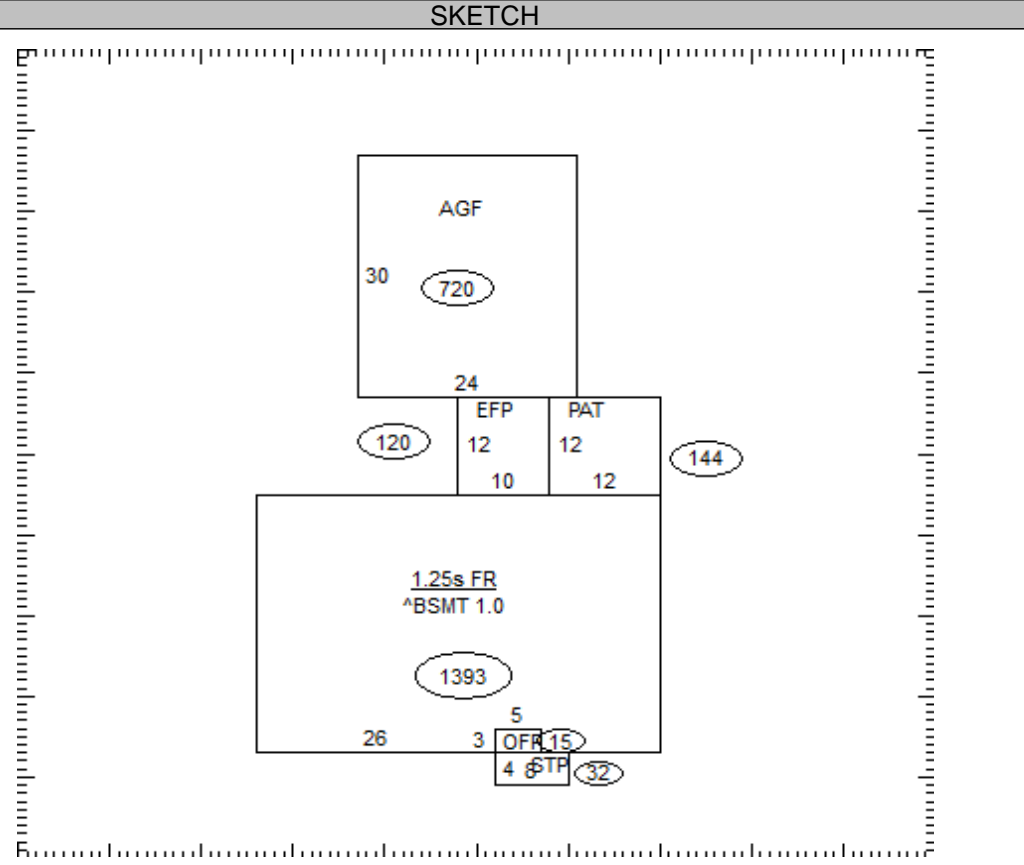

OCCUPANCY	ST.HT	SIZE	AREA	GRADE	PRICE	AGE	REMD	CND	UNADJ VAL	PHYS	PHYS VAL	FUNC	TRUE VAL
DWELLING	1.25	SK	1,741	C		1955		A	292,580	42	169,700		229,100
1													
2													
3													
4													
5													
6													
7													
8													
9													
10													
11													

31-043200.0000

TOTAL 229,100

COMMENTS

Dwelling has an Economic Factor of 135%

31-043200.0000

WINNER NANCEE ETAL

WINNER NANCEE ETAL
7243 MERCER DARKE COUNTY LINE RD
MARIA STEIN, OH 45860

LEGAL INFORMATION

TANGEMAN ADDITION
IN LOT 2

	OWNERSHIP	ADDRESS	CITY	STATE	ZIP	DATE	AMOUNT	DEED:CONV#	JS	VALID
1	TANGEMAN ROBERT B	2040 NORTHVIEW DR	MARIA STEIN	OH	45860		0	:0	<input type="checkbox"/>	<input type="checkbox"/>
2							0	0	<input type="checkbox"/>	<input type="checkbox"/>
3							0	0	<input type="checkbox"/>	<input type="checkbox"/>

X: TTO LISTER: NS DATE: 12/08/2004 TIME: 12:00:00 AM LETTER LETTER REC'D GIS CODE

STREET/ROAD	TOPOGRAPHY	PU-UTILITIES-PR	NEIGHBORHOOD	INFLUENCE FACTORS	PROPERTY LOCATION	
<input checked="" type="checkbox"/> PAVED <input type="checkbox"/> GRAVEL <input type="checkbox"/> DIRT <input type="checkbox"/> SIDEWALKS <input type="checkbox"/> CURBS	<input checked="" type="checkbox"/> LEVEL <input type="checkbox"/> HIGH <input type="checkbox"/> LOW <input type="checkbox"/> ROLLING <input type="checkbox"/> STANDARD	<input type="checkbox"/> WATER <input type="checkbox"/> SEWER <input checked="" type="checkbox"/> GAS <input checked="" type="checkbox"/> ELECTRIC <input type="checkbox"/> STANDARD	<input type="checkbox"/> IMPROVING <input checked="" type="checkbox"/> STATIC <input type="checkbox"/> DECLINING <input type="checkbox"/> OLD <input type="checkbox"/> STANDARD	<input type="checkbox"/> A. NO ROAD <input type="checkbox"/> B. TOPGRHY <input type="checkbox"/> C. Ex Front <input type="checkbox"/> D. QUANTITY <input type="checkbox"/> E. SZ/SHAPE	<input type="checkbox"/> F. RESTRICT <input type="checkbox"/> G. WOOD LT <input type="checkbox"/> H. VACANCY <input type="checkbox"/> I. WATER FRONT <input type="checkbox"/> J. OTHER/CDU	2040 NORTHVIEW DR, MARIA STEIN COMMENT

LAND COMPUTATIONS							
LAND TYPE	SIZE	M	RATE	C	INF	M	VALUE C
TOTAL							34,800 0

VALUATION SUMMARY

VALUE YEAR	REASON FOR CHANGE	APPRaised	IMPR	TOTAL	ASSESSED	IMPR	TOTAL

OCCUPANCY	EXTERIOR	FLOOR	AREA	CONST	VALUE
<input type="checkbox"/> SF <input type="checkbox"/> DU <input type="checkbox"/> TR	<input type="checkbox"/> WOOD				
<input type="checkbox"/> CONVERSION	<input type="checkbox"/> STUCCO				
BUILDING TYPE	<input type="checkbox"/> ALM/VYNL				
<input type="checkbox"/> MOBILE HOME	<input type="checkbox"/> CONC BLK				
<input type="checkbox"/> BI/TR LEVEL	<input type="checkbox"/> METAL				
<input type="checkbox"/> MOD/MAN	<input type="checkbox"/> BRICK				
<input type="checkbox"/> _____	<input type="checkbox"/> STONE				

ROOFING	ROOF TYPE
<input type="checkbox"/> METAL	<input type="checkbox"/> GABLE
<input type="checkbox"/> SLT/TLE	<input type="checkbox"/> HIP
<input type="checkbox"/> SHINGLES	<input type="checkbox"/> GAMBREL
<input type="checkbox"/> SHAKES	<input type="checkbox"/> MANSARD
<input type="checkbox"/> COMPOSITE	<input type="checkbox"/> FLAT

FLOORS	B	1	2	3	U
CONCRETE	<input type="checkbox"/>	<input type="checkbox"/>	<input type="checkbox"/>	<input type="checkbox"/>	<input type="checkbox"/>
WOOD	<input type="checkbox"/>	<input type="checkbox"/>	<input type="checkbox"/>	<input type="checkbox"/>	<input type="checkbox"/>
TILE/COMPO	<input type="checkbox"/>	<input type="checkbox"/>	<input type="checkbox"/>	<input type="checkbox"/>	<input type="checkbox"/>
CARPET	<input type="checkbox"/>	<input type="checkbox"/>	<input type="checkbox"/>	<input type="checkbox"/>	<input type="checkbox"/>
INT. FINISH	B	1	2	3	U
PLASTER/DW	<input type="checkbox"/>	<input type="checkbox"/>	<input type="checkbox"/>	<input type="checkbox"/>	<input type="checkbox"/>
PANELING	<input type="checkbox"/>	<input type="checkbox"/>	<input type="checkbox"/>	<input type="checkbox"/>	<input type="checkbox"/>
UNFINISHED	<input type="checkbox"/>	<input type="checkbox"/>	<input type="checkbox"/>	<input type="checkbox"/>	<input type="checkbox"/>
ACCOMMODATIONS					
# OF ROOMS					
BEDROOMS					
FIREPLACES					
HEAT & AC	B	1	2	3	U
NO HEAT	<input type="checkbox"/>	<input type="checkbox"/>	<input type="checkbox"/>	<input type="checkbox"/>	<input type="checkbox"/>
CTRL HEAT	<input type="checkbox"/>	<input type="checkbox"/>	<input type="checkbox"/>	<input type="checkbox"/>	<input type="checkbox"/>
HW/STEAM	<input type="checkbox"/>	<input type="checkbox"/>	<input type="checkbox"/>	<input type="checkbox"/>	<input type="checkbox"/>
ELECTRIC	<input type="checkbox"/>	<input type="checkbox"/>	<input type="checkbox"/>	<input type="checkbox"/>	<input type="checkbox"/>
HEAT PUMP	<input type="checkbox"/>	<input type="checkbox"/>	<input type="checkbox"/>	<input type="checkbox"/>	<input type="checkbox"/>
FLR/WALL	<input type="checkbox"/>	<input type="checkbox"/>	<input type="checkbox"/>	<input type="checkbox"/>	<input type="checkbox"/>
STVE/SPCE	<input type="checkbox"/>	<input type="checkbox"/>	<input type="checkbox"/>	<input type="checkbox"/>	<input type="checkbox"/>
GEO THERMAL	<input type="checkbox"/>	<input type="checkbox"/>	<input type="checkbox"/>	<input type="checkbox"/>	<input type="checkbox"/>
OUTSIDE	<input type="checkbox"/>	<input type="checkbox"/>	<input type="checkbox"/>	<input type="checkbox"/>	<input type="checkbox"/>
CTRL A/C	<input type="checkbox"/>	<input type="checkbox"/>	<input type="checkbox"/>	<input type="checkbox"/>	<input type="checkbox"/>
PLUMBING					
X FULL BATH					
X HALF BATH					
X FIXTURES					

SUBTOTAL		0
MULTI-FAMILY #	0	0
BUILDING TYPE	000%	0
BSMT FINISH	0 S.F.	0
FIREPLACE #	0	0
HEATING	0 S.F.	0
AIR COND	0 S.F.	0
PLUMBING #	0	0
GARAGES & CARPORTS		0
EXTRA FEATURES		0
SUBTOTAL		0
GRADE FACTOR		%
UNADJUSTED VALUE		0
FACTOR		%

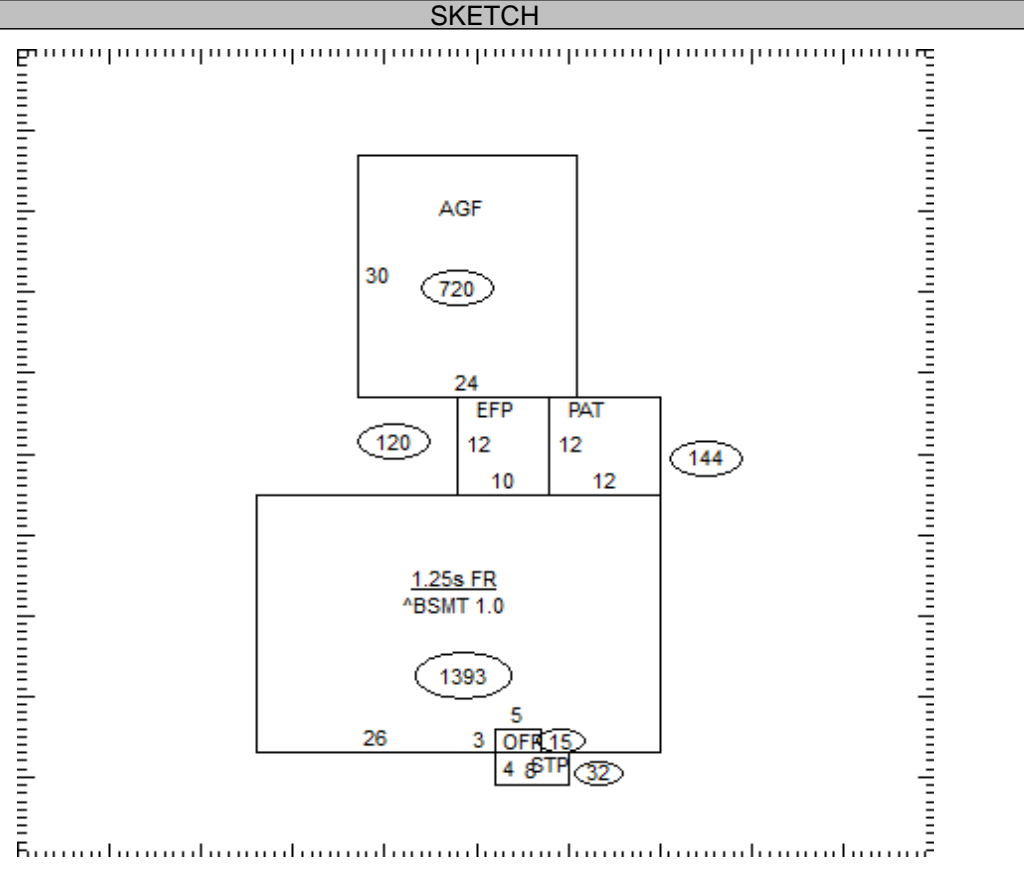

OCCUPANCY	ST.HT	SIZE	AREA	GRADE	PRICE	AGE	REMD	CND	UNADJ VAL	PHYS	PHYS VAL	FUNC	TRUE VAL
DWELLING		SK											
1													
2													
3													
4													
5													
6													
7													
8													
9													
10													
11													

31-043200.0000

TOTAL 0

COMMENTS