

LIBERTY TWP / PARKWAY SD

04-17-300-010

Property Class: 510

Neighborhood

003005-RS50

Map:

Block:

Card:

Bk:

Pg:

30-028700.0000

**LEGAL INFORMATION**

CULLY SUBDIVISION

LOT#: 8

Acres:1.4200 M:0.0000

**EVERETT KELLY J**

EVERETT KELLY J

619 FRAHM PIKE

CELINA, OH 45822

	OWNERSHIP	ADDRESS	CITY	STATE	ZIP	DATE	AMOUNT	DEED:CONV#	JS	VALID
1	EVERETT KELLY J	619 FRAHM PIKE	CELINA	OH	45822	10/19/2021	165,000	WDC : 892	<input type="checkbox"/>	<input checked="" type="checkbox"/>
2	SEVERT STEVEN & AMANDA	619 FRAHM PIKE	CELINA	OH	45822	07/09/2015	103,900	WDC : 453	<input type="checkbox"/>	<input type="checkbox"/>
3	AMERICAN ESCROW &	1699 WALL ST	MOUNT PROSPECT	IL	60056	07/09/2015	0	QCE : X : 0	<input type="checkbox"/>	<input type="checkbox"/>

X:  TTO LISTER: DATE: 10/24/2013 TIME: 12:00:00 AM  LETTER  LETTER REC'D GIS CODE

STREET/ROAD	TOPOGRAPHY	PU-UTILITIES-PR	NEIGHBORHOOD	INFLUENCE FACTORS				PROPERTY LOCATION	
<input checked="" type="checkbox"/> PAVED	<input checked="" type="checkbox"/> LEVEL	<input type="checkbox"/> WATER	<input checked="" type="checkbox"/> IMPROVING	<input type="checkbox"/> A. NO ROAD	<input type="checkbox"/> F. RESTRICT	619 FRAHM PIKE, CELINA			
<input type="checkbox"/> GRAVEL	<input type="checkbox"/> HIGH	<input type="checkbox"/> SEWER	<input checked="" type="checkbox"/> STATIC	<input type="checkbox"/> B. TOPGRHY	<input type="checkbox"/> G. WOOD LT	COMMENT			
<input type="checkbox"/> DIRT	<input type="checkbox"/> LOW	<input checked="" type="checkbox"/> GAS	<input type="checkbox"/> DECLINING	<input checked="" type="checkbox"/> C. Ex Front	<input type="checkbox"/> H. VACANCY	TY2022:Net Gen=\$1,896.78, Other			
<input type="checkbox"/> SIDEWALKS	<input type="checkbox"/> ROLLING	<input checked="" type="checkbox"/> ELECTRIC	<input type="checkbox"/> OLD	<input type="checkbox"/> D. QUANTITY	<input type="checkbox"/> I. WATER FRONT	Assessment=\$2.00			
<input type="checkbox"/> CURBS	<input type="checkbox"/> STANDARD	<input type="checkbox"/> STANDARD	<input type="checkbox"/> STANDARD	<input type="checkbox"/> E. SZ/SHAPE	<input type="checkbox"/> J. OTHER/CDU	DE14 RMV DFLT ON BARN/USABLE			
LAND COMPUTATIONS						DE16 DESKTOP RVW CHG: COR STRY HGT			
LAND TYPE	SIZE	M	RATE	C	INF	M	VALUE	C	
F:Front	F223 D277	ST160	DP119	ADJ190	C:0.2		33,900	0	
TOTAL							33,900	0	

**VALUATION SUMMARY**

VALUE YEAR	2023	2020	2017				
REASON FOR CHANGE	RAPP	RAPP	RAPP				
APPRAISED	LAND	33,900	27,900	26,600			
VALUE	IMPR	121,300	98,000	87,200			
	TOTAL	155,200	125,900	113,800			
ASSESSED	LAND	11,870	9,770	9,310			
VALUE	IMPR	42,460	34,300	30,520			
	TOTAL	54,330	44,070	39,830			

**OCCUPANCY**  SF  DU  TR  BI/TR LEVEL  MOD/MAN

**EXTERIOR**  WOOD  STUCCO  ALM/VYNL  CONC BLK  METAL  BRICK  STONE

**ROOFING**  METAL  SLT/TLE  SHINGLES  SHAKES  COMPOSITE

**ROOF TYPE**  GABLE  HIP  GAMBREL  MANSARD  FLAT

**FLOORS** B 1 2 3 U

CONCRETE

WOOD

TILE/COMPO

CARPET

**INT. FINISH** B 1 2 3 U

PLASTER/DW

PANELING

UNFINISHED

**ACCOMMODATIONS**

# OF ROOMS 6 3

BEDROOMS 1 3

FIREPLACES 1

HEAT & AC B 1 2 3 U

NO HEAT

CTRL HEAT

HW/STEAM

ELECTRIC

HEAT PUMP

FLR/WALL

STVE/SPCE

GEO THERMAL

OUTSIDE

CTRL A/C

**PLUMBING** BASE

X FULL BATH

X HALF BATH 1

X FIXTURES

FLOOR	AREA	CONST	VALUE
1	1478	FR	200,770
.75	528	FR	36,340
BSMT	352		5,030
<b>SUBTOTAL</b>			<b>242,140</b>
MULTI-FAMILY #	0		0
BUILDING TYPE	100%		0
BSMT FINISH	0 S.F.		0
FIREPLACE #	1		4,400
HEATING	0 S.F.		0
AIR COND	2,006 S.F.		3,310
PLUMBING #	2		2,420
GARAGES & CARPORTS			20,800
EXTRA FEATURES			2,000
<b>SUBTOTAL</b>			<b>275,070</b>
GRADE FACTOR			100 %
<b>UNADJUSTED VALUE</b>			<b>275,070</b>
FACTOR			100 %

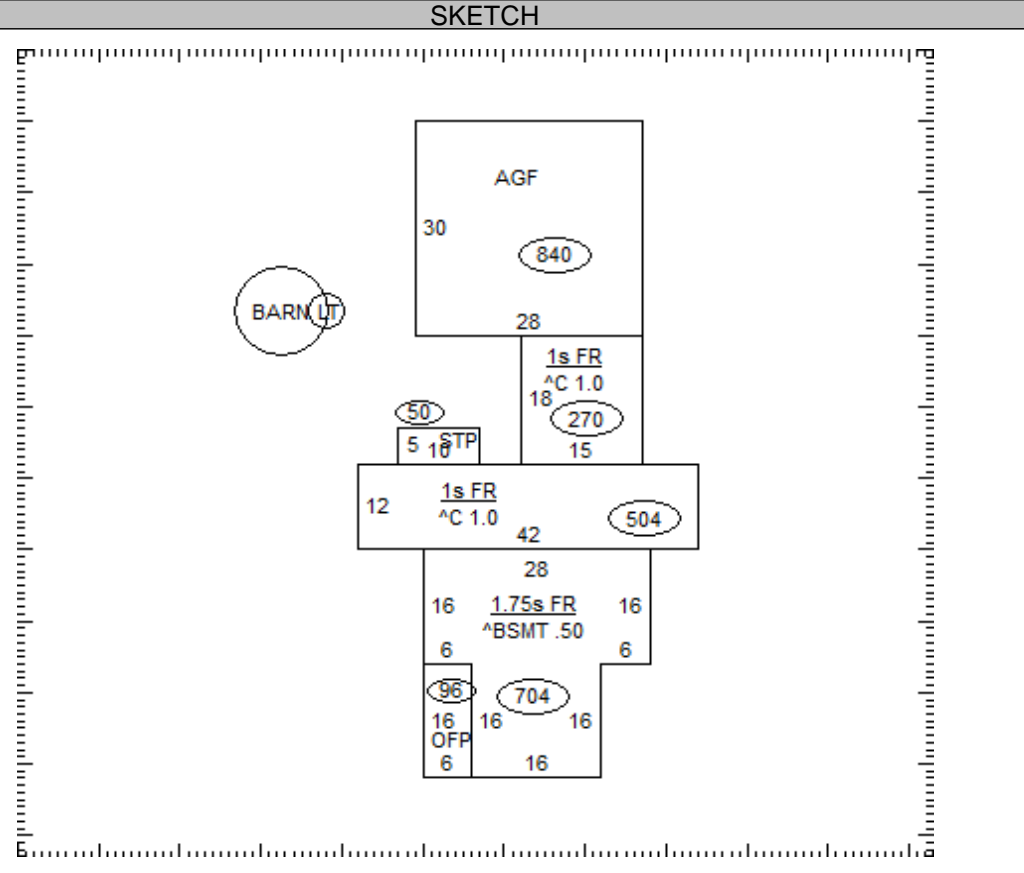

OCCUPANCY	ST.HT	SIZE	AREA	GRADE	PRICE	AGE	REMD	CND	UNADJ VAL	PHYS	PHYS VAL	FUNC	TRUE VAL
DWELLING	1.75	SK	2,006	C		1900		A	275,070	45	151,290		121,000
1 Barn	12	14x30	420	D	9.60	1920		F	4,030	95	200		200
2 Lean - To	8	14x30	420	C	4.80	1930		F	2,020	95	100		100
3													
4													
5													
6													
7													
8													
9													
10													
11													

30-028700.0000

TOTAL 121,300

**COMMENTS**

Dwelling has an Economic Factor of 80% (Rollback Basis=\$154,900)

LIBERTY TWP / PARKWAY SD

04-17-300-010

Property Class: 510

Neighborhood

003005-RS50

Map:

Block:

Card:

Bk: Pg:

30-028700.0000

LEGAL INFORMATION

CULLY SUBDIVISION

LOT#: 8

Acres:1.4200 M:0.0000

EVERETT KELLY J

EVERETT KELLY J

619 FRAHM PIKE

CELINA, OH 45822

	OWNERSHIP	ADDRESS	CITY	STATE	ZIP	DATE	AMOUNT	DEED:CONV#	JS	VALID
1	HEINEY CASEY & AMBER	619 FRAHM PIKE	CELINA	OH	45822	05/21/2014	114,000	WDC : 280	<input type="checkbox"/>	<input checked="" type="checkbox"/>
2	BOLLENBACHER LINDA A	619 FRAHM PIKE	CELINA	OH	45822	11/30/2012	0	QCE : X : 0	<input type="checkbox"/>	<input type="checkbox"/>
3	BOLLENBACHER LARRY D &	619 FRAHM PIKE	CELINA	OH	45822	08/18/1997	90,000	: A : 0	<input type="checkbox"/>	<input checked="" type="checkbox"/>

X:  TTO LISTER: DATE: 10/24/2013 TIME: 12:00:00 AM  LETTER  LETTER REC'D GIS CODE

STREET/ROAD TOPOGRAPHY PU-UTILITIES-PR NEIGHBORHOOD INFLUENCE FACTORS PROPERTY LOCATION

<input checked="" type="checkbox"/> PAVED	<input checked="" type="checkbox"/> LEVEL	<input type="checkbox"/> WATER	<input checked="" type="checkbox"/> IMPROVING	<input type="checkbox"/> A. NO ROAD	<input type="checkbox"/> F. RESTRICT	619 FRAHM PIKE, CELINA COMMENT
<input type="checkbox"/> GRAVEL	<input type="checkbox"/> HIGH	<input type="checkbox"/> SEWER	<input checked="" type="checkbox"/> STATIC	<input type="checkbox"/> B. TOPGRHY	<input type="checkbox"/> G. WOOD LT	
<input type="checkbox"/> DIRT	<input type="checkbox"/> LOW	<input checked="" type="checkbox"/> GAS	<input type="checkbox"/> DECLINING	<input checked="" type="checkbox"/> C. Ex Front	<input type="checkbox"/> H. VACANCY	
<input type="checkbox"/> SIDEWALKS	<input type="checkbox"/> ROLLING	<input checked="" type="checkbox"/> ELECTRIC	<input type="checkbox"/> OLD	<input type="checkbox"/> D. QUANTITY	<input type="checkbox"/> I. WATER FRONT	
<input type="checkbox"/> CURBS	<input type="checkbox"/> STANDARD	<input type="checkbox"/> STANDARD	<input type="checkbox"/> STANDARD	<input type="checkbox"/> E. SZ/SHAPE	<input type="checkbox"/> J. OTHER/CDU	

LAND COMPUTATIONS

LAND TYPE	SIZE	M	RATE	C	INF	M	VALUE	C
TOTAL						33,900	0	

VALUATION SUMMARY

VALUE YEAR	REASON FOR CHANGE	APPRaised	IMPR	TOTAL	ASSESSED	IMPR	TOTAL

OCCUPANCY	EXTERIOR	FLOOR	AREA	CONST	VALUE
<input type="checkbox"/> SF <input type="checkbox"/> DU <input type="checkbox"/> TR	<input type="checkbox"/> WOOD				
<input type="checkbox"/> CONVERSION	<input type="checkbox"/> STUCCO				
<b>BUILDING TYPE</b>	<input type="checkbox"/> ALM/VYNL				
<input type="checkbox"/> MOBILE HOME	<input type="checkbox"/> CONC BLK				
<input type="checkbox"/> BI/TR LEVEL	<input type="checkbox"/> METAL				
<input type="checkbox"/> MOD/MAN	<input type="checkbox"/> BRICK				
<input type="checkbox"/>	<input type="checkbox"/> STONE				

ROOFING	ROOF TYPE
<input type="checkbox"/> METAL	<input type="checkbox"/> GABLE
<input type="checkbox"/> SLT/TLE	<input type="checkbox"/> HIP
<input type="checkbox"/> SHINGLES	<input type="checkbox"/> GAMBREL
<input type="checkbox"/> SHAKES	<input type="checkbox"/> MANSARD
<input type="checkbox"/> COMPOSITE	<input type="checkbox"/> FLAT

FLOORS	B	1	2	3	U
CONCRETE	<input type="checkbox"/>	<input type="checkbox"/>	<input type="checkbox"/>	<input type="checkbox"/>	<input type="checkbox"/>
WOOD	<input type="checkbox"/>	<input type="checkbox"/>	<input type="checkbox"/>	<input type="checkbox"/>	<input type="checkbox"/>
TILE/COMPO	<input type="checkbox"/>	<input type="checkbox"/>	<input type="checkbox"/>	<input type="checkbox"/>	<input type="checkbox"/>
CARPET	<input type="checkbox"/>	<input type="checkbox"/>	<input type="checkbox"/>	<input type="checkbox"/>	<input type="checkbox"/>
INT. FINISH	B	1	2	3	U
PLASTER/DW	<input type="checkbox"/>	<input type="checkbox"/>	<input type="checkbox"/>	<input type="checkbox"/>	<input type="checkbox"/>
PANELING	<input type="checkbox"/>	<input type="checkbox"/>	<input type="checkbox"/>	<input type="checkbox"/>	<input type="checkbox"/>
UNFINISHED	<input type="checkbox"/>	<input type="checkbox"/>	<input type="checkbox"/>	<input type="checkbox"/>	<input type="checkbox"/>
ACCOMMODATIONS					
# OF ROOMS					
BEDROOMS					
FIREPLACES					
HEAT & AC	B	1	2	3	U
NO HEAT	<input type="checkbox"/>	<input type="checkbox"/>	<input type="checkbox"/>	<input type="checkbox"/>	<input type="checkbox"/>
CTRL HEAT	<input type="checkbox"/>	<input type="checkbox"/>	<input type="checkbox"/>	<input type="checkbox"/>	<input type="checkbox"/>
HW/STEAM	<input type="checkbox"/>	<input type="checkbox"/>	<input type="checkbox"/>	<input type="checkbox"/>	<input type="checkbox"/>
ELECTRIC	<input type="checkbox"/>	<input type="checkbox"/>	<input type="checkbox"/>	<input type="checkbox"/>	<input type="checkbox"/>
HEAT PUMP	<input type="checkbox"/>	<input type="checkbox"/>	<input type="checkbox"/>	<input type="checkbox"/>	<input type="checkbox"/>
FLR/WALL	<input type="checkbox"/>	<input type="checkbox"/>	<input type="checkbox"/>	<input type="checkbox"/>	<input type="checkbox"/>
STVE/SPCE	<input type="checkbox"/>	<input type="checkbox"/>	<input type="checkbox"/>	<input type="checkbox"/>	<input type="checkbox"/>
GEO THERMAL	<input type="checkbox"/>	<input type="checkbox"/>	<input type="checkbox"/>	<input type="checkbox"/>	<input type="checkbox"/>
OUTSIDE	<input type="checkbox"/>	<input type="checkbox"/>	<input type="checkbox"/>	<input type="checkbox"/>	<input type="checkbox"/>
CTRL A/C	<input type="checkbox"/>	<input type="checkbox"/>	<input type="checkbox"/>	<input type="checkbox"/>	<input type="checkbox"/>
PLUMBING					BASE <input type="checkbox"/>
X FULL BATH					
X HALF BATH					
X FIXTURES					

<b>SUBTOTAL</b>		0
MULTI-FAMILY #	0	0
BUILDING TYPE	000%	0
BSMT FINISH	0 S.F.	0
FIREPLACE #	0	0
HEATING	0 S.F.	0
AIR COND	0 S.F.	0
PLUMBING #	0	0
GARAGES & CARPORTS		0
EXTRA FEATURES		0
<b>SUBTOTAL</b>		0
GRADE FACTOR		%
<b>UNADJUSTED VALUE</b>		0
FACTOR		%

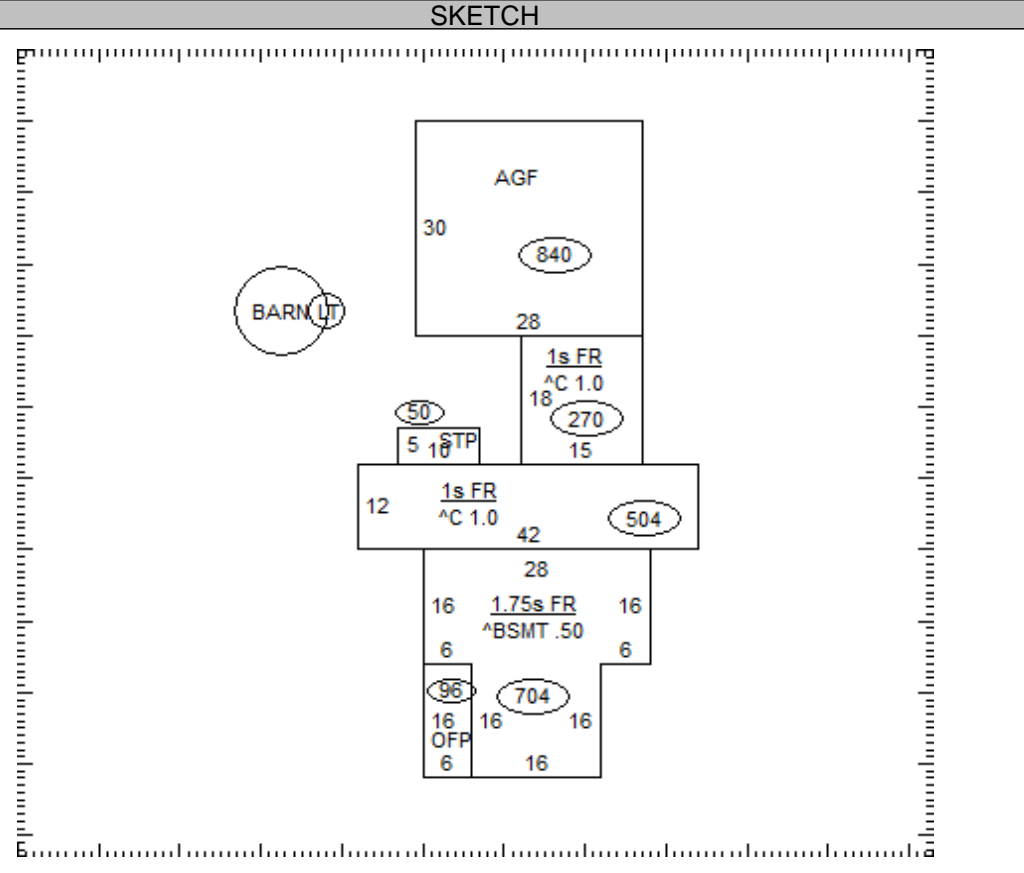

OCCUPANCY	ST.HT	SIZE	AREA	GRADE	PRICE	AGE	REMD	CND	UNADJ VAL	PHYS	PHYS VAL	FUNC	TRUE VAL
DWELLING		SK											
1													
2													
3													
4													
5													
6													
7													
8													
9													
10													
11													

30-028700.0000

TOTAL 0

COMMENTS