

Property Class: 510

Neighborhood  
009305-R150

Map:  
Block:  
Card:

Bk: Pg:

LIBERTY TWP / PARKWAY SD

04-15-400-003

30-025800.0000

**LEGAL INFORMATION**

PT E 1/2 SE

RTS: 001-05-15  
Acres:5.4170

**THOMAS GALE A & NELDA G TRUSTEES**

THOMAS GALE A & NELDA G TRUSTEES

8155 BURRVILLE RD

CELINA, OH 45822

	OWNERSHIP	ADDRESS	CITY	STATE	ZIP	DATE	AMOUNT	DEED:CONV#	JS	VALID
1	THOMAS GALE A & NELDA G	8155 BURRVILLE RD	CELINA	OH	45822	03/06/2023	76,000	WDC : 115	<input type="checkbox"/>	<input checked="" type="checkbox"/>
2	FAST ARNOLD	8585 BURRVILLE RD	CELINA	OH	45822	06/25/1991	0	: X : 0	<input type="checkbox"/>	<input type="checkbox"/>
3							0	0	<input type="checkbox"/>	<input type="checkbox"/>

X:  TTO LISTER: TM DATE: 06/29/2004 TIME: 02:55:54 PM  LETTER  LETTER REC'D GIS CODE

STREET/ROAD	TOPOGRAPHY	PU-UTILITIES-PR	NEIGHBORHOOD	INFLUENCE FACTORS				PROPERTY LOCATION
<input checked="" type="checkbox"/> PAVED	<input checked="" type="checkbox"/> LEVEL	<input type="checkbox"/> WATER	<input type="checkbox"/> IMPROVING	<input type="checkbox"/> A. NO ROAD	<input type="checkbox"/> F. RESTRICT	8585 BURRVILLE RD, CELINA		
<input type="checkbox"/> GRAVEL	<input type="checkbox"/> HIGH	<input type="checkbox"/> SEWER	<input type="checkbox"/> STATIC	<input type="checkbox"/> B. TOPGRHY	<input type="checkbox"/> G. WOOD LT	COMMENT		
<input type="checkbox"/> DIRT	<input type="checkbox"/> LOW	<input type="checkbox"/> GAS	<input type="checkbox"/> DECLINING	<input type="checkbox"/> C. Ex Front	<input type="checkbox"/> H. VACANCY	TY2022:Net Gen=\$1,351.60, Other		
<input type="checkbox"/> SIDEWALKS	<input type="checkbox"/> ROLLING	<input type="checkbox"/> ELECTRIC	<input type="checkbox"/> OLD	<input type="checkbox"/> D. QUANTITY	<input type="checkbox"/> I. WATER FRONT	Assessment=\$4.82		
<input type="checkbox"/> CURBS	<input type="checkbox"/> STANDARD	<input checked="" type="checkbox"/> STANDARD	<input type="checkbox"/> STANDARD	<input type="checkbox"/> E. SZ/SHAPE	<input type="checkbox"/> J. OTHER/CDU	DE14 REMOVED FROM CAUV// REQUESTED		
LAND COMPUTATIONS						SCH F// NO REPLY		
LAND TYPE	SIZE	M	RATE	C	INF	M	VALUE	C
HS:Home Site	AC:1	23390				23,400	0	
SM:Small Acreage	AC:4.417	7700				34,000	0	
Total Acres: 5.4170						TOTAL	57,400	0

DE16 DESKTOP RVW CHG: COR OUTBLDGS  
DE23 DWLG VACANT, POOR COND; ALLOW VAC FNC

**VALUATION SUMMARY**

VALUE YEAR	2023	2023	2020	2017
REASON FOR CHANGE	RAPP	MISC	RAPP	RAPP
APPRAISED VALUE	LAND	57,400	51,300	51,300
	IMPR	36,700	22,000	37,500
	TOTAL	94,100	73,300	88,800
ASSESSED VALUE	LAND	20,090	17,960	17,960
	IMPR	12,850	7,700	13,130
	TOTAL	32,940	25,660	31,090

OCCUPANCY	EXTERIOR	FLOOR	AREA	CONST	VALUE
<input checked="" type="checkbox"/> SF <input type="checkbox"/> DU <input type="checkbox"/> TR	<input checked="" type="checkbox"/> WOOD	1	1088	FR	169,710
<input type="checkbox"/> CONVERSION	<input type="checkbox"/> STUCCO	.5	368	FR	35,590
<b>BUILDING TYPE</b>	<input type="checkbox"/> ALM/VYNL				
<input type="checkbox"/> MOBILE HOME	<input type="checkbox"/> CONC BLK				
<input type="checkbox"/> BI/TR LEVEL	<input type="checkbox"/> METAL				
<input type="checkbox"/> MOD/MAN	<input type="checkbox"/> BRICK				
<input type="checkbox"/> _____	<input type="checkbox"/> STONE				
<b>ROOFING</b>	<b>ROOF TYPE</b>				
<input type="checkbox"/> METAL	<input type="checkbox"/> GABLE				
<input type="checkbox"/> SLT/TLE	<input type="checkbox"/> HIP				
<input checked="" type="checkbox"/> SHINGLES	<input type="checkbox"/> GAMBREL				
<input type="checkbox"/> SHAKES	<input type="checkbox"/> MANSARD				
<input type="checkbox"/> COMPOSITE	<input type="checkbox"/> FLAT				
<b>FLOORS</b>	<b>B 1 2 3 U</b>	BSMT	808		11,550
CONCRETE	<input checked="" type="checkbox"/> <input type="checkbox"/> <input type="checkbox"/> <input type="checkbox"/> <input type="checkbox"/>	<b>SUBTOTAL</b>			216,850
WOOD	<input type="checkbox"/> <input checked="" type="checkbox"/> <input checked="" type="checkbox"/> <input type="checkbox"/> <input type="checkbox"/>	MULTI-FAMILY #	0		0
TILE/COMPO	<input type="checkbox"/> <input type="checkbox"/> <input type="checkbox"/> <input type="checkbox"/> <input type="checkbox"/>	BUILDING TYPE	100%		0
CARPET	<input type="checkbox"/> <input type="checkbox"/> <input type="checkbox"/> <input type="checkbox"/> <input type="checkbox"/>	BSMT FINISH	0 S.F.		0
<b>INT. FINISH</b>	<b>B 1 2 3 U</b>	FIREPLACE #	0		0
PLASTER/DW	<input type="checkbox"/> <input checked="" type="checkbox"/> <input checked="" type="checkbox"/> <input type="checkbox"/> <input type="checkbox"/>	HEATING	0 S.F.		0
PANELING	<input type="checkbox"/> <input type="checkbox"/> <input type="checkbox"/> <input type="checkbox"/> <input type="checkbox"/>	AIR COND	0 S.F.		0
UNFINISHED	<input checked="" type="checkbox"/> <input type="checkbox"/> <input type="checkbox"/> <input type="checkbox"/> <input type="checkbox"/>	PLUMBING #	0		0
<b>ACCOMMODATIONS</b>		GARAGES & CARPORTS			0
# OF ROOMS		EXTRA FEATURES			1,300
BEDROOMS		<b>SUBTOTAL</b>			218,150
FIREPLACES		GRADE FACTOR			80 %
HEAT & AC		<b>UNADJUSTED VALUE</b>			174,520
NO HEAT	<input type="checkbox"/> <input type="checkbox"/> <input type="checkbox"/> <input type="checkbox"/> <input type="checkbox"/>	<b>FACTOR</b>			100 %
CTRL HEAT	<input type="checkbox"/> <input checked="" type="checkbox"/> <input checked="" type="checkbox"/> <input type="checkbox"/> <input type="checkbox"/>				
HW/STEAM	<input type="checkbox"/> <input type="checkbox"/> <input type="checkbox"/> <input type="checkbox"/> <input type="checkbox"/>				
ELECTRIC	<input type="checkbox"/> <input type="checkbox"/> <input type="checkbox"/> <input type="checkbox"/> <input type="checkbox"/>				
HEAT PUMP	<input type="checkbox"/> <input type="checkbox"/> <input type="checkbox"/> <input type="checkbox"/> <input type="checkbox"/>				
FLR/WALL	<input type="checkbox"/> <input type="checkbox"/> <input type="checkbox"/> <input type="checkbox"/> <input type="checkbox"/>				
STVE/SPCE	<input type="checkbox"/> <input type="checkbox"/> <input type="checkbox"/> <input type="checkbox"/> <input type="checkbox"/>				
GEO THERMAL	<input type="checkbox"/> <input type="checkbox"/> <input type="checkbox"/> <input type="checkbox"/> <input type="checkbox"/>				
OUTSIDE	<input type="checkbox"/> <input type="checkbox"/> <input type="checkbox"/> <input type="checkbox"/> <input type="checkbox"/>				
CTRL A/C	<input type="checkbox"/> <input type="checkbox"/> <input type="checkbox"/> <input type="checkbox"/> <input type="checkbox"/>				
<b>PLUMBING</b>	<b>BASE</b> <input checked="" type="checkbox"/>				
X FULL BATH					
X HALF BATH					
X FIXTURES					

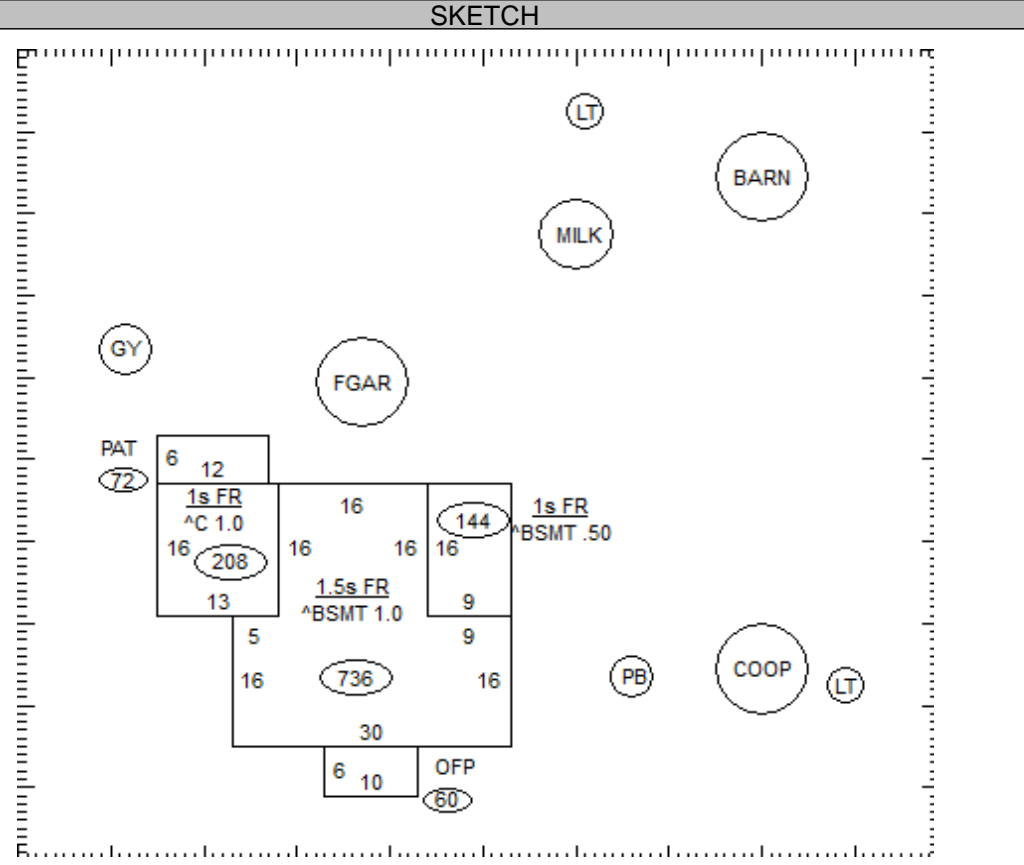

OCCUPANCY	ST.HT	SIZE	AREA	GRADE	PRICE	AGE	REMD	CND	UNADJ VAL	PHYS	PHYS VAL	FUNC	TRUE VAL
DWELLING	1.5	SK	1,456	D		1900		P	174,520	75	43,630	VAC25	32,700
1 Milk House / Par	8	16x30	480	C	18.00	1900		F	8,640	95	430	DFLT50	200
2 Coop	SV*	20x40	800	C		1900		F	200	95			200
3 Lean - To	6'	10x40	400	C	4.80	1981		F	1,920	78	420		400
4 Lean - To	10'	36x38	1,368	C	4.80	1974		P	6,570	85	990		1,000
5 Gar - Frame		10x32	320	C	23.70	1930		P	7,580	95	380		400
6 Granary	12	12x26	312	C	7.70	1930		P	2,400	95	120		100
7 Pole Bldg	12	28x28	784	C	14.32	1960		F	11,230	90	1,120		1,100
8 Barn	14	36x56	2,016	C	12.00	1900		F	24,190	95	1,210	DFLT50	600
9													
10													
11													

30-025800.0000 \* Value Override Item TOTAL 36,700

**COMMENTS**  
 Dwelling has an Economic Factor of 100% (Rollback Basis=\$56,500)