

OCCUPANCY		EXTERIOR		FLOOR	AREA	CONST	VALUE						
<input checked="" type="checkbox"/> SF	<input type="checkbox"/> DU	<input type="checkbox"/> TR	<input type="checkbox"/> WOOD	1	1104	FR	169,270						
<input type="checkbox"/> CONVERSION			<input type="checkbox"/> STUCCO	.5	420	FR	39,930						
BUILDING TYPE		<input checked="" type="checkbox"/> ALM/VYNL											
<input type="checkbox"/> MOBILE HOME			<input type="checkbox"/> CONC BLK										
<input type="checkbox"/> BI/TR LEVEL			<input type="checkbox"/> METAL										
<input type="checkbox"/> MOD/MAN			<input type="checkbox"/> BRICK										
<input type="checkbox"/>			<input type="checkbox"/> STONE										
ROOFING		ROOF TYPE											
<input type="checkbox"/> METAL			<input type="checkbox"/> GABLE										
<input type="checkbox"/> SLT/TLE			<input type="checkbox"/> HIP										
<input checked="" type="checkbox"/> SHINGLES			<input type="checkbox"/> GAMBREL										
<input type="checkbox"/> SHAKES			<input type="checkbox"/> MANSARD										
<input type="checkbox"/> COMPOSITE			<input type="checkbox"/> FLAT										
FLOORS		B	1	2	3	U							
CONCRETE	<input checked="" type="checkbox"/>	<input type="checkbox"/>	<input type="checkbox"/>	<input type="checkbox"/>	<input type="checkbox"/>	<input type="checkbox"/>							
WOOD	<input type="checkbox"/>	<input type="checkbox"/>	<input type="checkbox"/>	<input type="checkbox"/>	<input type="checkbox"/>	<input type="checkbox"/>							
TILE/COMPO	<input type="checkbox"/>	<input checked="" type="checkbox"/>	<input type="checkbox"/>	<input type="checkbox"/>	<input type="checkbox"/>	<input type="checkbox"/>							
CARPET	<input type="checkbox"/>	<input checked="" type="checkbox"/>	<input checked="" type="checkbox"/>	<input type="checkbox"/>	<input type="checkbox"/>	<input type="checkbox"/>							
INT. FINISH		B	1	2	3	U							
PLASTER/DW	<input type="checkbox"/>	<input checked="" type="checkbox"/>	<input checked="" type="checkbox"/>	<input type="checkbox"/>	<input type="checkbox"/>	<input type="checkbox"/>							
PANELING	<input type="checkbox"/>	<input type="checkbox"/>	<input type="checkbox"/>	<input type="checkbox"/>	<input type="checkbox"/>	<input type="checkbox"/>							
UNFINISHED	<input checked="" type="checkbox"/>	<input type="checkbox"/>	<input type="checkbox"/>	<input type="checkbox"/>	<input type="checkbox"/>	<input type="checkbox"/>							
ACCOMMODATIONS													
# OF ROOMS		5	2										
BEDROOMS		1	2										
FIREPLACES		1											
HEAT & AC		B	1	2	3	U							
NO HEAT	<input type="checkbox"/>	<input type="checkbox"/>	<input type="checkbox"/>	<input type="checkbox"/>	<input type="checkbox"/>	<input type="checkbox"/>							
CTRL HEAT	<input type="checkbox"/>	<input checked="" type="checkbox"/>	<input checked="" type="checkbox"/>	<input type="checkbox"/>	<input type="checkbox"/>	<input type="checkbox"/>							
HW/STEAM	<input type="checkbox"/>	<input type="checkbox"/>	<input type="checkbox"/>	<input type="checkbox"/>	<input type="checkbox"/>	<input type="checkbox"/>							
ELECTRIC	<input type="checkbox"/>	<input type="checkbox"/>	<input type="checkbox"/>	<input type="checkbox"/>	<input type="checkbox"/>	<input type="checkbox"/>							
HEAT PUMP	<input type="checkbox"/>	<input type="checkbox"/>	<input type="checkbox"/>	<input type="checkbox"/>	<input type="checkbox"/>	<input type="checkbox"/>							
FLR/WALL	<input type="checkbox"/>	<input type="checkbox"/>	<input type="checkbox"/>	<input type="checkbox"/>	<input type="checkbox"/>	<input type="checkbox"/>							
STVE/SPCE	<input type="checkbox"/>	<input checked="" type="checkbox"/>	<input type="checkbox"/>	<input type="checkbox"/>	<input type="checkbox"/>	<input type="checkbox"/>							
GEOHERMAL	<input type="checkbox"/>	<input type="checkbox"/>	<input type="checkbox"/>	<input type="checkbox"/>	<input type="checkbox"/>	<input type="checkbox"/>							
OUTSIDE	<input type="checkbox"/>	<input type="checkbox"/>	<input type="checkbox"/>	<input type="checkbox"/>	<input type="checkbox"/>	<input type="checkbox"/>							
CTRL A/C	<input type="checkbox"/>	<input checked="" type="checkbox"/>	<input checked="" type="checkbox"/>	<input type="checkbox"/>	<input type="checkbox"/>	<input type="checkbox"/>							
PLUMBING		BASE		<input checked="" type="checkbox"/>									
X FULL BATH			1										
X HALF BATH													
X FIXTURES		1											
BSMT		474					6,780						
SUBTOTAL						215,980							
MULTI-FAMILY #		0				0							
BUILDING TYPE		100%				0							
BSMT FINISH		0 S.F.				0							
FIREPLACE #		1				4,400							
HEATING		0 S.F.				0							
AIR COND		1,524 S.F.				2,510							
PLUMBING #		4				4,840							
GARAGES & CARPORTS						0							
EXTRA FEATURES						5,900							
SUBTOTAL						233,630							
GRADE FACTOR						100 %							
UNADJUSTED VALUE						233,630							
FACTOR						100 %							
OCCUPANCY	ST.HT	SIZE	AREA	GRADE	PRICE	AGE	REMD	CND	UNADJ VAL	PHYS	PHYS VAL	FUNC	TRUE VAL
DWELLING	1.5	SK	1,524	C		1906	2003	G	233,630	26	172,890		172,900
1 Gar - Frame		10x20	200	C	23.70	1920		A	4,740	95	240		200
2 Barn		30x20	600	C	12.00	1999		A	7,200	37	4,540		4,500
3 Gar - Frame		24x52	1,248	C	23.70	1999		A	29,580	37	18,640		18,600
4 Shed		10x20	200	C	9.90	1999		A	1,980	37	1,250		1,300
5													
6													
7													
8													
9													
10													
11													

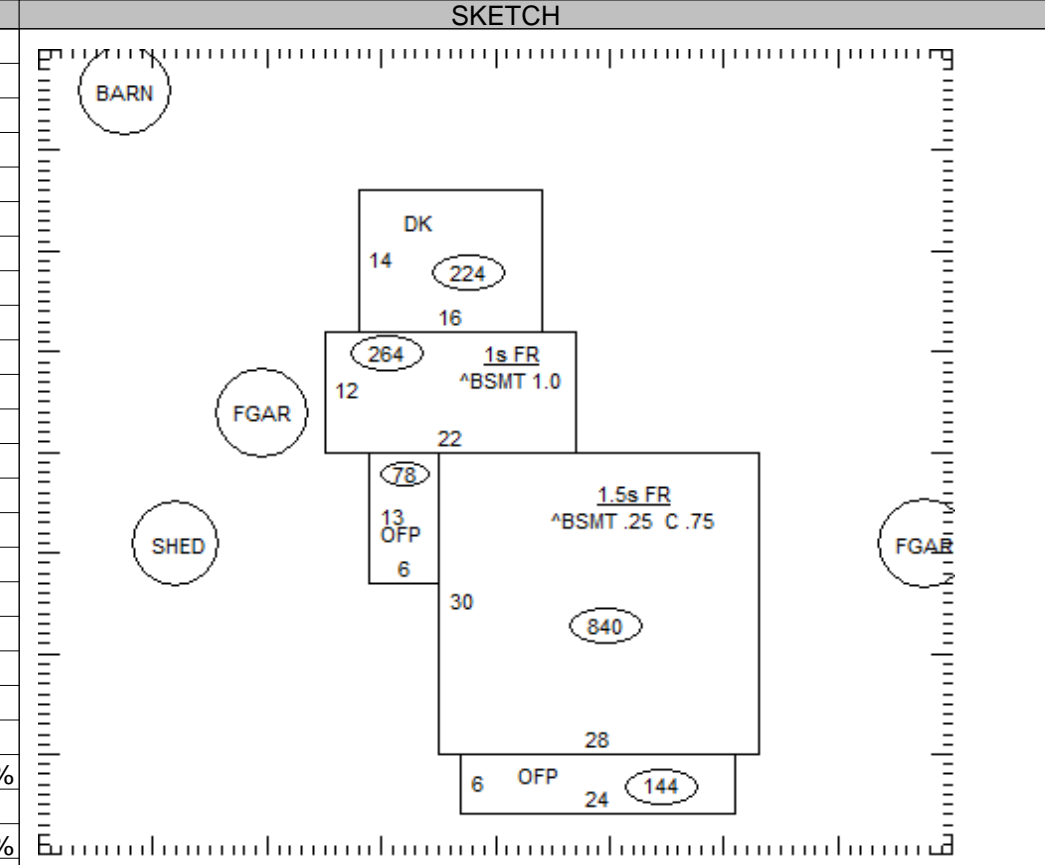

30-023200.0200

TOTAL 197,500

COMMENTS

Dwelling has an Economic Factor of 100% (Rollback Basis=\$214,900)