

JEFFERSON TWP-CELINA CORP / CELINA SD

05-36-126-022

Property Class: 510

Neighborhood

27502700-03 -

Map: 01 B

Block:

Card: 60

Bk: Pg:

27-477709.0000

**HOENIE CODY M**

HOENIE CODY M  
1425 MICHAEL AVE  
CELINA, OH 45822

**LEGAL INFORMATION**

PLAT & REPLAT OF TRACT NO. 3  
AND LOTS NO. 82 THRU 91 OF BRUNS SUB  
LOT#: 150

	OWNERSHIP	ADDRESS	CITY	STATE	ZIP	DATE	AMOUNT	DEED:CONV#	JS	VALID
1	HOENIE CODY M	1425 MICHAEL AVE	CELINA	OH	45822	05/06/2021	229,900	WDC : 350	<input type="checkbox"/>	<input checked="" type="checkbox"/>
2	RHYNE SHIRLEY A & BARBARA	1425 MICHAEL AVE	CELINA	OH	45822	09/17/1990	17,400	: A : 0	<input type="checkbox"/>	<input type="checkbox"/>
3							0	0	<input type="checkbox"/>	<input type="checkbox"/>

X:  TTO LISTER: JO DATE: 05/17/2005 TIME: 12:00:00 AM  LETTER  LETTER REC'D GIS CODE

STREET/ROAD	TOPOGRAPHY	PU-UTILITIES-PR	NEIGHBORHOOD	INFLUENCE FACTORS	PROPERTY LOCATION	
<input checked="" type="checkbox"/> PAVED <input type="checkbox"/> GRAVEL <input type="checkbox"/> DIRT <input checked="" type="checkbox"/> SIDEWALKS <input type="checkbox"/> CURBS	<input checked="" type="checkbox"/> LEVEL <input type="checkbox"/> HIGH <input type="checkbox"/> LOW <input type="checkbox"/> ROLLING <input type="checkbox"/> STANDARD	<input type="checkbox"/> WATER <input type="checkbox"/> SEWER <input type="checkbox"/> GAS <input type="checkbox"/> ELECTRIC <input checked="" type="checkbox"/> STANDARD	<input checked="" type="checkbox"/> IMPROVING <input type="checkbox"/> STATIC <input type="checkbox"/> DECLINING <input type="checkbox"/> OLD <input type="checkbox"/> STANDARD	<input type="checkbox"/> A. NO ROAD <input type="checkbox"/> B. TOPGRHY <input type="checkbox"/> C. Ex Front <input type="checkbox"/> D. QUANTITY <input type="checkbox"/> E. SZ/SHAPE	<input type="checkbox"/> F. RESTRICT <input type="checkbox"/> G. WOOD LT <input type="checkbox"/> H. VACANCY <input type="checkbox"/> I. WATER FRONT <input type="checkbox"/> J. OTHER/CDU	1425 MICHAEL AVE, CELINA <b>COMMENT</b> TY2022:Net Gen=\$3,679.66, Other Assessment=\$0.00 DE16 DESKTOP REVIEW//ADD VAULTED CEILING DE22 RMV OWN OCC - DID NOT RETURN APP

LAND COMPUTATIONS

LAND TYPE	SIZE	M	RATE	C	INF	M	VALUE	C
F:Front	F110 D115	ST430	DP87	ADJ374			41,100	0
						TOTAL	41,100	0

VALUATION SUMMARY

VALUE YEAR	2023	2020	2017
REASON FOR CHANGE	RAPP	RAPP	RAPP
APPRAISED VALUE	LAND 41,100	30,400	24,900
	IMPR 257,300	197,300	161,700
	TOTAL 298,400	227,700	186,600
ASSESSED VALUE	LAND 14,390	10,640	8,720
	IMPR 90,060	69,060	56,600
	TOTAL 104,450	79,700	65,320

<b>OCCUPANCY</b>		<b>EXTERIOR</b>	
<input checked="" type="checkbox"/> SF	<input type="checkbox"/> DU	<input type="checkbox"/> WOOD	<input type="checkbox"/> STUCCO
<input type="checkbox"/> TR	<input type="checkbox"/> CONVERSION	<input type="checkbox"/> ALM/VYNL	<input type="checkbox"/> CONC BLK
<b>BUILDING TYPE</b>		<input type="checkbox"/> METAL	<input checked="" type="checkbox"/> BRICK
<input type="checkbox"/> MOBILE HOME	<input type="checkbox"/> BI/TR LEVEL	<input type="checkbox"/> GAMBREL	<input type="checkbox"/> MANSARD
<input type="checkbox"/> MOD/MAN	<input type="checkbox"/>	<input type="checkbox"/> FLAT	<input type="checkbox"/>

<b>ROOFING</b>		<b>ROOF TYPE</b>	
<input type="checkbox"/> METAL	<input checked="" type="checkbox"/> GABLE	<input type="checkbox"/> HIP	<input type="checkbox"/>
<input type="checkbox"/> SLT/TLE	<input type="checkbox"/>	<input type="checkbox"/>	<input type="checkbox"/>
<input checked="" type="checkbox"/> SHINGLES	<input type="checkbox"/>	<input type="checkbox"/>	<input type="checkbox"/>
<input type="checkbox"/> SHAKES	<input type="checkbox"/>	<input type="checkbox"/>	<input type="checkbox"/>
<input type="checkbox"/> COMPOSITE	<input type="checkbox"/>	<input type="checkbox"/>	<input type="checkbox"/>

<b>FLOORS</b>		B	1	2	3	U
CONCRETE	<input checked="" type="checkbox"/>	<input type="checkbox"/>	<input type="checkbox"/>	<input type="checkbox"/>	<input type="checkbox"/>	<input type="checkbox"/>
WOOD	<input type="checkbox"/>	<input type="checkbox"/>	<input type="checkbox"/>	<input type="checkbox"/>	<input type="checkbox"/>	<input type="checkbox"/>
TILE/COMPO	<input type="checkbox"/>	<input checked="" type="checkbox"/>	<input type="checkbox"/>	<input type="checkbox"/>	<input type="checkbox"/>	<input type="checkbox"/>
CARPET	<input type="checkbox"/>	<input checked="" type="checkbox"/>	<input type="checkbox"/>	<input type="checkbox"/>	<input type="checkbox"/>	<input type="checkbox"/>

<b>INT. FINISH</b>		B	1	2	3	U
PLASTER/DW	<input type="checkbox"/>	<input checked="" type="checkbox"/>	<input type="checkbox"/>	<input type="checkbox"/>	<input type="checkbox"/>	<input type="checkbox"/>
PANELING	<input type="checkbox"/>	<input type="checkbox"/>	<input type="checkbox"/>	<input type="checkbox"/>	<input type="checkbox"/>	<input type="checkbox"/>
UNFINISHED	<input checked="" type="checkbox"/>	<input type="checkbox"/>	<input type="checkbox"/>	<input type="checkbox"/>	<input type="checkbox"/>	<input type="checkbox"/>

<b>ACCOMMODATIONS</b>						
# OF ROOMS		6				
BEDROOMS		3				
FIREPLACES		1				
<b>HEAT &amp; AC</b>		B	1	2	3	U

NO HEAT	<input type="checkbox"/>	<input type="checkbox"/>	<input type="checkbox"/>	<input type="checkbox"/>	<input type="checkbox"/>
CTRL HEAT	<input type="checkbox"/>	<input checked="" type="checkbox"/>	<input type="checkbox"/>	<input type="checkbox"/>	<input type="checkbox"/>
HW/STEAM	<input type="checkbox"/>	<input type="checkbox"/>	<input type="checkbox"/>	<input type="checkbox"/>	<input type="checkbox"/>
ELECTRIC	<input type="checkbox"/>	<input type="checkbox"/>	<input type="checkbox"/>	<input type="checkbox"/>	<input type="checkbox"/>
HEAT PUMP	<input type="checkbox"/>	<input type="checkbox"/>	<input type="checkbox"/>	<input type="checkbox"/>	<input type="checkbox"/>
FLR/WALL	<input type="checkbox"/>	<input type="checkbox"/>	<input type="checkbox"/>	<input type="checkbox"/>	<input type="checkbox"/>
STVE/SPCE	<input type="checkbox"/>	<input type="checkbox"/>	<input type="checkbox"/>	<input type="checkbox"/>	<input type="checkbox"/>
GEOTHERMAL	<input type="checkbox"/>	<input type="checkbox"/>	<input type="checkbox"/>	<input type="checkbox"/>	<input type="checkbox"/>
OUTSIDE	<input type="checkbox"/>	<input type="checkbox"/>	<input type="checkbox"/>	<input type="checkbox"/>	<input type="checkbox"/>
CTRL A/C	<input type="checkbox"/>	<input checked="" type="checkbox"/>	<input type="checkbox"/>	<input type="checkbox"/>	<input type="checkbox"/>

<b>PLUMBING</b>		<b>BASE</b>			
X FULL BATH		1			
X HALF BATH					
X FIXTURES					

FLOOR	AREA	CONST	VALUE
1	1859	BRK	240,410
BSMT	1859		26,580
<b>SUBTOTAL</b>			266,990
MULTI-FAMILY #	0		0
BUILDING TYPE	100%		0
BSMT FINISH	0 S.F.		0
FIREPLACE #	1		4,400
HEATING	0 S.F.		0
AIR COND	1,859 S.F.		3,070
PLUMBING #	3		3,630
GARAGES & CARPORTS			16,100
EXTRA FEATURES			15,700
<b>SUBTOTAL</b>			309,890
GRADE FACTOR			115 %
<b>UNADJUSTED VALUE</b>			356,370
FACTOR			100 %

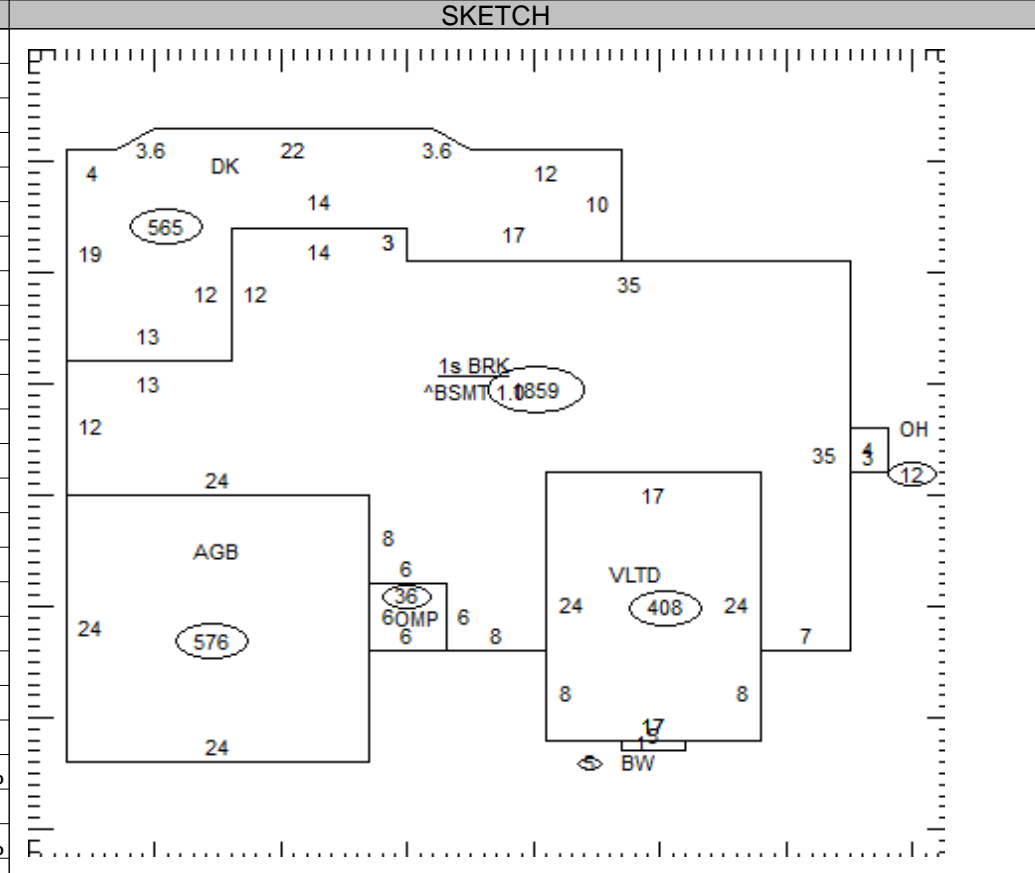

OCCUPANCY	ST.HT	SIZE	AREA	GRADE	PRICE	AGE	REMD	CND	UNADJ VAL	PHYS	PHYS VAL	FUNC	TRUE VAL
DWELLING	1	SK	1,859	B-		1991		A	356,370	24	270,840		257,300
1													
2													
3													
4													
5													
6													
7													
8													
9													
10													
11													

27-477709.0000 TOTAL 257,300

**COMMENTS**

Dwelling has an Economic Factor of 95%