

27-461200.0000

**BEAT WILLIAM R & HOLLY S**

BEAT WILLIAM R & HOLLY S

1217 TOUVELLE ST

CELINA, OH 45822

**LEGAL INFORMATION**

FLECK FIRST SUBD

ALSO PT LOT 7

LOT#: 6

	OWNERSHIP	ADDRESS	CITY	STATE	ZIP	DATE	AMOUNT	DEED:CONV#	JS	VALID
1	BEAT WILLIAM R & HOLLY S	1217 TOUVELLE ST	CELINA	OH	45822	04/21/2023	240,000	WDC : 207	<input type="checkbox"/>	<input checked="" type="checkbox"/>
2	MONNIN SHAWN & MONNIN	9991 COUNTY ROAD 66A	NEW BREMEN	OH	45869	10/07/2022	0	QCE : X : 0	<input type="checkbox"/>	<input type="checkbox"/>
3	MONNIN MICHAEL J	1217 TOUVELLE ST	CELINA	OH	45822	07/28/2020	0	QCE : X : 0	<input type="checkbox"/>	<input type="checkbox"/>

X:  TTO LISTER: HK DATE: 02/03/2020 TIME: 12:00:00 AM  LETTER  LETTER REC'D GIS CODE

STREET/ROAD TOPOGRAPHY PU-UTILITIES-PR NEIGHBORHOOD INFLUENCE FACTORS PROPERTY LOCATION

PAVED  LEVEL  WATER  IMPROVING  A. NO ROAD  F. RESTRICT 1217 TOUVELLE ST, CELINA  
 GRAVEL  HIGH  SEWER  STATIC  B. TOPGRHY  G. WOOD LT COMMENT  
 DIRT  LOW  GAS  DECLINING  C. Ex Front  H. VACANCY TY2022:Net Gen=\$2,054.04, Other  
 SIDEWALKS  ROLLING  ELECTRIC  OLD  D. QUANTITY  I. WATER FRONT Assessment=\$0.00  
 CURBS  STANDARD  STANDARD  STANDARD  E. SZ/SHAPE  J. OTHER/CDU DE17 FIELDCHK RVW CHGS: ADD BW, CHG  
WDDK TO OFP  
DE19 5/27/2019 TORNADO DAMAGE  
DE20 TTO; RMV FNC, ADD SHED

LAND COMPUTATIONS

LAND TYPE	SIZE	M	RATE	C	INF	M	VALUE	C
F:Front	F148 D120	ST290	DP89	ADJ258			38,200	0
TOTAL							38,200	0

VALUATION SUMMARY

VALUE YEAR	2023	2020	2020	2020	2019	2017	2017	
REASON FOR CHANGE	RAPP	RAPP	NC	MISC	REMB	RAPP	MISC	
APPRAISED	LAND	38,200	37,000	33,000	33,000	22,300	22,300	20,800
VALUE	IMPR	180,200	117,900	103,200	81,400	81,400	101,800	86,000
	TOTAL	218,400	154,900	136,200	114,400	103,700	124,100	106,800
ASSESSED	LAND	13,370	12,950	11,550	11,550	7,810	7,810	7,280
VALUE	IMPR	63,070	41,270	36,120	28,490	28,490	35,630	30,100
	TOTAL	76,440	54,220	47,670	40,040	36,300	43,440	37,380

<input checked="" type="checkbox"/> SF <input type="checkbox"/> DU <input type="checkbox"/> TR	<input checked="" type="checkbox"/> WOOD	FLOOR	AREA	CONST	VALUE
<input type="checkbox"/> CONVERSION	<input type="checkbox"/> STUCCO	1	1458	FR	198,050
<b>BUILDING TYPE</b>	<input type="checkbox"/> ALM/VYNL	.25	364	FR	45,150
<input type="checkbox"/> MOBILE HOME	<input type="checkbox"/> CONC BLK				
<input type="checkbox"/> BI/TR LEVEL	<input type="checkbox"/> METAL				
<input type="checkbox"/> MOD/MAN	<input type="checkbox"/> BRICK				
<input type="checkbox"/> _____	<input type="checkbox"/> STONE				

<b>ROOFING</b>	<b>ROOF TYPE</b>
<input type="checkbox"/> METAL	<input checked="" type="checkbox"/> GABLE
<input type="checkbox"/> SLT/TLE	<input checked="" type="checkbox"/> HIP
<input checked="" type="checkbox"/> SHINGLES	<input type="checkbox"/> GAMBREL
<input type="checkbox"/> SHAKES	<input type="checkbox"/> MANSARD
<input type="checkbox"/> COMPOSITE	<input type="checkbox"/> FLAT

<b>FLOORS</b>	B	1	2	3	U
CONCRETE	<input type="checkbox"/>	<input type="checkbox"/>	<input type="checkbox"/>	<input type="checkbox"/>	<input type="checkbox"/>
WOOD	<input type="checkbox"/>	<input type="checkbox"/>	<input type="checkbox"/>	<input type="checkbox"/>	<input type="checkbox"/>
TILE/COMPO	<input type="checkbox"/>	<input checked="" type="checkbox"/>	<input type="checkbox"/>	<input type="checkbox"/>	<input type="checkbox"/>
CARPET	<input type="checkbox"/>	<input checked="" type="checkbox"/>	<input type="checkbox"/>	<input type="checkbox"/>	<input type="checkbox"/>
<b>INT. FINISH</b>	B	1	2	3	U
PLASTER/DW	<input type="checkbox"/>	<input checked="" type="checkbox"/>	<input type="checkbox"/>	<input type="checkbox"/>	<input type="checkbox"/>
PANELING	<input type="checkbox"/>	<input type="checkbox"/>	<input type="checkbox"/>	<input type="checkbox"/>	<input type="checkbox"/>
UNFINISHED	<input type="checkbox"/>	<input type="checkbox"/>	<input type="checkbox"/>	<input type="checkbox"/>	<input type="checkbox"/>
<b>ACCOMMODATIONS</b>					
# OF ROOMS		7			
BEDROOMS		3			
FIREPLACES		1			
<b>HEAT &amp; AC</b>	B	1	2	3	U
NO HEAT	<input type="checkbox"/>	<input type="checkbox"/>	<input type="checkbox"/>	<input type="checkbox"/>	<input type="checkbox"/>
CTRL HEAT	<input type="checkbox"/>	<input checked="" type="checkbox"/>	<input checked="" type="checkbox"/>	<input type="checkbox"/>	<input type="checkbox"/>
HW/STEAM	<input type="checkbox"/>	<input type="checkbox"/>	<input type="checkbox"/>	<input type="checkbox"/>	<input type="checkbox"/>
ELECTRIC	<input type="checkbox"/>	<input type="checkbox"/>	<input type="checkbox"/>	<input type="checkbox"/>	<input type="checkbox"/>
HEAT PUMP	<input type="checkbox"/>	<input checked="" type="checkbox"/>	<input checked="" type="checkbox"/>	<input type="checkbox"/>	<input type="checkbox"/>
FLR/WALL	<input type="checkbox"/>	<input type="checkbox"/>	<input type="checkbox"/>	<input type="checkbox"/>	<input type="checkbox"/>
STVE/SPCE	<input type="checkbox"/>	<input type="checkbox"/>	<input type="checkbox"/>	<input type="checkbox"/>	<input type="checkbox"/>
GEOTHERMAL	<input type="checkbox"/>	<input type="checkbox"/>	<input type="checkbox"/>	<input type="checkbox"/>	<input type="checkbox"/>
OUTSIDE	<input type="checkbox"/>	<input type="checkbox"/>	<input type="checkbox"/>	<input type="checkbox"/>	<input type="checkbox"/>
CTRL A/C	<input type="checkbox"/>	<input checked="" type="checkbox"/>	<input checked="" type="checkbox"/>	<input type="checkbox"/>	<input type="checkbox"/>
<b>PLUMBING</b>					<b>BASE</b> <input checked="" type="checkbox"/>
X FULL BATH		1			
X HALF BATH		1			
X FIXTURES					

<b>SUBTOTAL</b>		243,200
MULTI-FAMILY #	0	0
BUILDING TYPE	100%	0
BSMT FINISH	0 S.F.	0
FIREPLACE #	1	4,400
HEATING	0 S.F.	0
AIR COND	1,822 S.F.	3,010
PLUMBING #	5	6,050
GARAGES & CARPORTS		14,200
EXTRA FEATURES		4,000
<b>SUBTOTAL</b>		274,860
GRADE FACTOR		105 %
<b>UNADJUSTED VALUE</b>		288,600
FACTOR		100 %

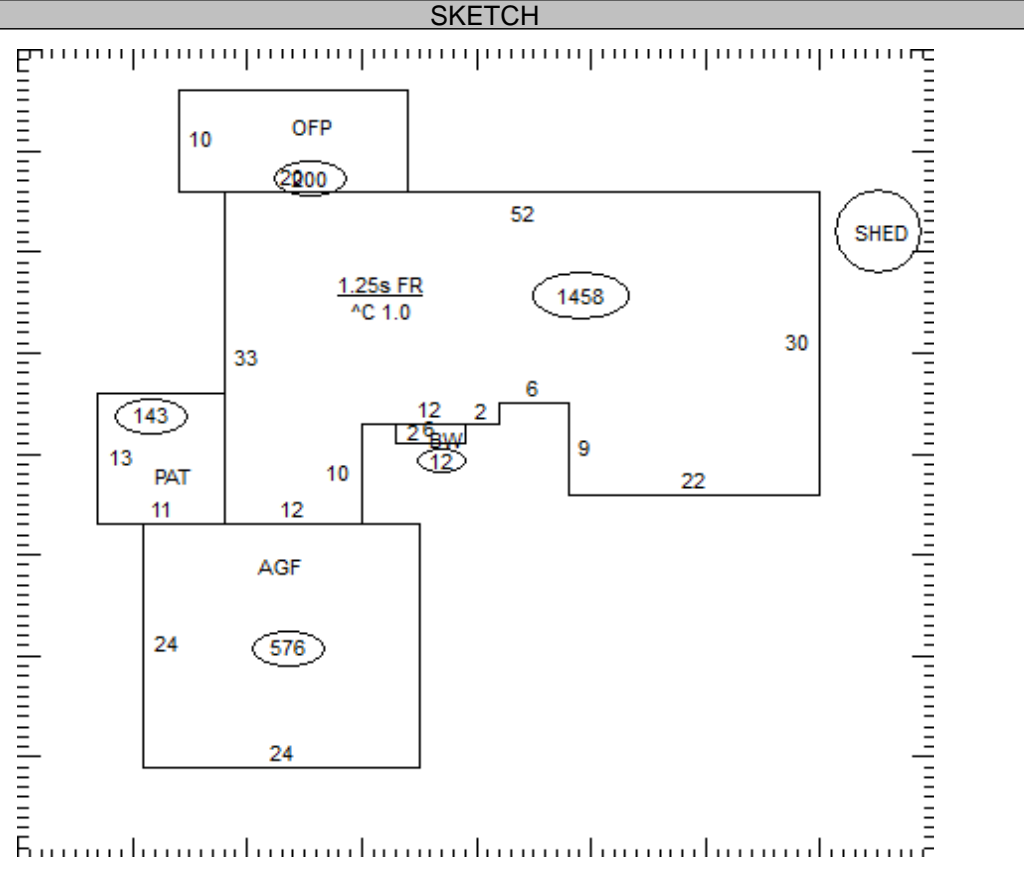

OCCUPANCY	ST.HT	SIZE	AREA	GRADE	PRICE	AGE	REMD	CND	UNADJ VAL	PHYS	PHYS VAL	FUNC	TRUE VAL
DWELLING	1.25	SK	1,822	C+		1983		A	288,600	28	207,790		178,700
1 Shed		10x16	160	C	9.90	2019		A	1,580	4	1,520		1,500
2													
3													
4													
5													
6													
7													
8													
9													
10													
11													

27-461200.0000 TOTAL 180,200

**COMMENTS**

FRAME W/MS 30 L/F BRICK TRIM 8' HIGH  
 Dwelling has an Economic Factor of 86% (Rollback Basis=\$216,900)

27-461200.0000

**BEAT WILLIAM R & HOLLY S**  
BEAT WILLIAM R & HOLLY S  
1217 TOUVELLE ST  
CELINA, OH 45822

**LEGAL INFORMATION**  
FLECK FIRST SUBD  
ALSO PT LOT 7  
LOT#: 6

	OWNERSHIP	ADDRESS	CITY	STATE	ZIP	DATE	AMOUNT	DEED:CONV#	JS	VALID
1	MONNIN MICHAEL J & PEGGY	1217 TOUVELLE ST	CELINA	OH	45822	05/22/2019	165,000	WDC : 335	<input type="checkbox"/>	<input checked="" type="checkbox"/>
2	BLAKE KAREN S	142 WINDING CREEK DR	SPRINGBORO	OH	45066	03/20/2019	0	QCE : X : 0	<input type="checkbox"/>	<input type="checkbox"/>
3	KITTLE MARTHA LOU & BLAKE	1217 TOUVELLE ST	CELINA	OH	45822	05/26/2011	0	QCE : X : 0	<input type="checkbox"/>	<input type="checkbox"/>

X:  TTO LISTER: HK DATE: 02/03/2020 TIME: 12:00:00 AM  LETTER  LETTER REC'D GIS CODE

STREET/ROAD	TOPOGRAPHY	PU-UTILITIES-PR	NEIGHBORHOOD	INFLUENCE FACTORS	PROPERTY LOCATION
<input checked="" type="checkbox"/> PAVED	<input checked="" type="checkbox"/> LEVEL	<input type="checkbox"/> WATER	<input type="checkbox"/> IMPROVING	<input type="checkbox"/> A. NO ROAD	1217 TOUVELLE ST, CELINA <b>COMMENT</b>
<input type="checkbox"/> GRAVEL	<input type="checkbox"/> HIGH	<input type="checkbox"/> SEWER	<input checked="" type="checkbox"/> STATIC	<input type="checkbox"/> B. TOPGRHY	
<input type="checkbox"/> DIRT	<input type="checkbox"/> LOW	<input type="checkbox"/> GAS	<input type="checkbox"/> DECLINING	<input type="checkbox"/> C. Ex Front	
<input type="checkbox"/> SIDEWALKS	<input type="checkbox"/> ROLLING	<input type="checkbox"/> ELECTRIC	<input type="checkbox"/> OLD	<input type="checkbox"/> D. QUANTITY	
<input type="checkbox"/> CURBS	<input type="checkbox"/> STANDARD	<input checked="" type="checkbox"/> STANDARD	<input type="checkbox"/> STANDARD	<input type="checkbox"/> E. SZ/SHAPE	
				<input type="checkbox"/> F. RESTRICT	

LAND COMPUTATIONS							
LAND TYPE	SIZE	M	RATE	C	INF	M	VALUE C
TOTAL						38,200	0

**VALUATION SUMMARY**

VALUE YEAR							
REASON FOR CHANGE							
APPRaised	<u>LAND</u>						
VALUE	<u>IMPR</u>						
	<u>TOTAL</u>						
ASSESSED	<u>LAND</u>						
VALUE	<u>IMPR</u>						
	<u>TOTAL</u>						

OCCUPANCY  
 SF  DU  TR  
 CONVERSION  
 BUILDING TYPE  
 MOBILE HOME  
 BI/TR LEVEL  
 MOD/MAN  
 \_\_\_\_\_

FLOOR	AREA	CONST	VALUE

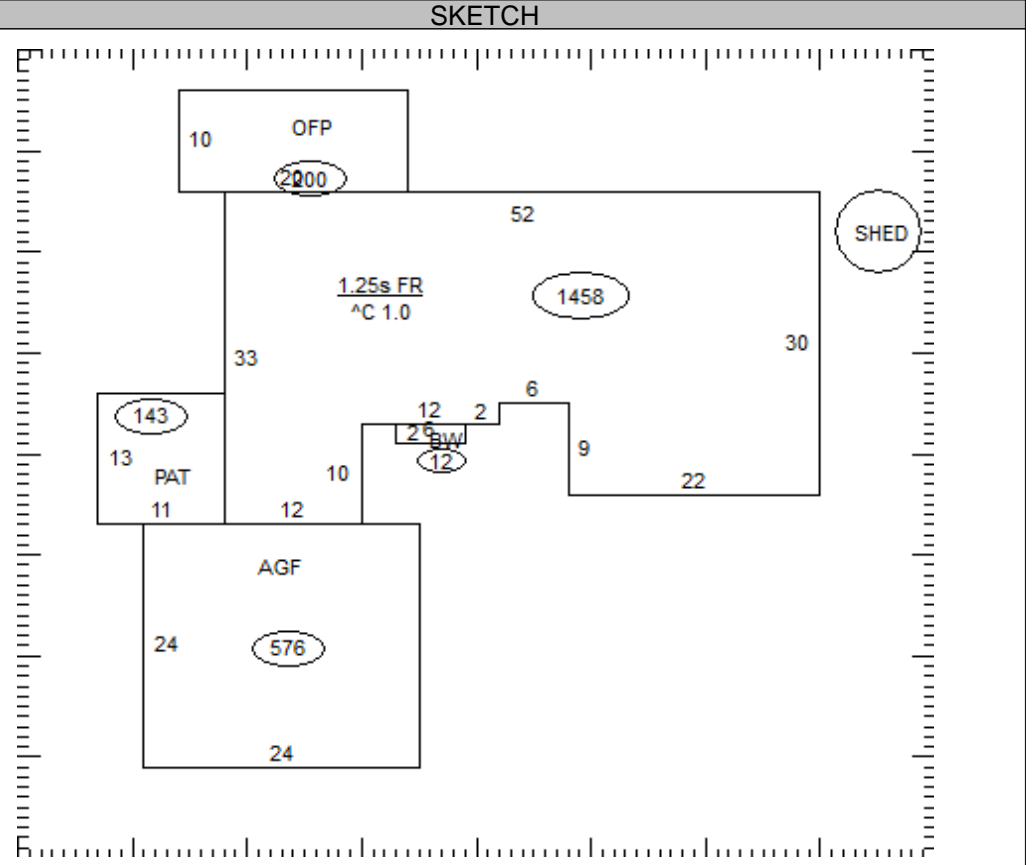

ROOFING ROOF TYPE  
 METAL  GABLE  
 SLT/TLE  HIP  
 SHINGLES  GAMBREL  
 SHAKES  MANSARD  
 COMPOSITE  FLAT

<b>SUBTOTAL</b>			0
MULTI-FAMILY #	0		0
BUILDING TYPE	000%		0
BSMT FINISH	0 S.F.		0
FIREPLACE #	0		0
HEATING	0 S.F.		0
AIR COND	0 S.F.		0
PLUMBING #	0		0
GARAGES & CARPORTS			0
EXTRA FEATURES			0
<b>SUBTOTAL</b>			0
GRADE FACTOR			%
<b>UNADJUSTED VALUE</b>			0
FACTOR			%

FLOORS B 1 2 3 U  
 CONCRETE       
 WOOD       
 TILE/COMPO       
 CARPET

OCCUPANCY	ST.HT	SIZE	AREA	GRADE	PRICE	AGE	REMD	CND	UNADJ VAL	PHYS	PHYS VAL	FUNC	TRUE VAL
DWELLING		SK											
1													
2													
3													
4													
5													
6													
7													
8													
9													
10													
11													

INT. FINISH B 1 2 3 U  
 PLASTER/DW       
 PANELING       
 UNFINISHED

ACCOMMODATIONS  
 # OF ROOMS       
 BEDROOMS       
 FIREPLACES       
 HEAT & AC B 1 2 3 U

NO HEAT       
 CTRL HEAT       
 HW/STEAM       
 ELECTRIC       
 HEAT PUMP       
 FLR/WALL       
 STVE/SPCE       
 GEOTHERMAL       
 OUTSIDE       
 CTRL A/C

PLUMBING BASE   
 X FULL BATH       
 X HALF BATH       
 X FIXTURES

27-461200.0000 TOTAL 0

COMMENTS

27-461200.0000

**BEAT WILLIAM R & HOLLY S**

BEAT WILLIAM R & HOLLY S

1217 TOUVELLE ST

CELINA, OH 45822

**LEGAL INFORMATION**

FLECK FIRST SUBD

ALSO PT LOT 7

LOT#: 6

	OWNERSHIP	ADDRESS	CITY	STATE	ZIP	DATE	AMOUNT	DEED:CONV#	JS	VALID
1	KITTLE MARTHA LOU	1217 TOUVELLE ST	CELINA	OH	45822	07/16/2010	0	QCE : X : 0	<input type="checkbox"/>	<input type="checkbox"/>
2	KITTLE LEONARD L & MARTHA	1217 TOUVELLE ST	CELINA	OH	45822	11/13/1995	100,000	: A : 0	<input type="checkbox"/>	<input checked="" type="checkbox"/>
3							0	0	<input type="checkbox"/>	<input type="checkbox"/>

X:  TTO LISTER: HK DATE: 02/03/2020 TIME: 12:00:00 AM  LETTER  LETTER REC'D GIS CODE

STREET/ROAD	TOPOGRAPHY	PU-UTILITIES-PR	NEIGHBORHOOD	INFLUENCE FACTORS	PROPERTY LOCATION
<input checked="" type="checkbox"/> PAVED	<input checked="" type="checkbox"/> LEVEL	<input type="checkbox"/> WATER	<input type="checkbox"/> IMPROVING	<input type="checkbox"/> A. NO ROAD	1217 TOUVELLE ST, CELINA
<input type="checkbox"/> GRAVEL	<input type="checkbox"/> HIGH	<input type="checkbox"/> SEWER	<input checked="" type="checkbox"/> STATIC	<input type="checkbox"/> B. TOPGRHY	<b>COMMENT</b>
<input type="checkbox"/> DIRT	<input type="checkbox"/> LOW	<input type="checkbox"/> GAS	<input type="checkbox"/> DECLINING	<input type="checkbox"/> C. Ex Front	
<input type="checkbox"/> SIDEWALKS	<input type="checkbox"/> ROLLING	<input type="checkbox"/> ELECTRIC	<input type="checkbox"/> OLD	<input type="checkbox"/> D. QUANTITY	
<input type="checkbox"/> CURBS	<input type="checkbox"/> STANDARD	<input checked="" type="checkbox"/> STANDARD	<input type="checkbox"/> STANDARD	<input type="checkbox"/> E. SZ/SHAPE	
				<input type="checkbox"/> F. RESTRICT	
				<input type="checkbox"/> G. WOOD LT	
				<input type="checkbox"/> H. VACANCY	
				<input type="checkbox"/> I. WATER FRONT	
				<input type="checkbox"/> J. OTHER/CDU	

LAND COMPUTATIONS							
LAND TYPE	SIZE	M	RATE	C	INF	M	VALUE C
TOTAL						38,200	0

**VALUATION SUMMARY**

VALUE YEAR	REASON FOR CHANGE	APPRaised	LAND IMPR	TOTAL	ASSESSED	LAND IMPR	TOTAL

<b>OCCUPANCY</b>		<b>EXTERIOR</b>		<b>FLOOR</b>	<b>AREA</b>	<b>CONST</b>	<b>VALUE</b>
<input type="checkbox"/> SF	<input type="checkbox"/> DU	<input type="checkbox"/> TR	<input type="checkbox"/> WOOD				
<input type="checkbox"/> CONVERSION			<input type="checkbox"/> STUCCO				
<b>BUILDING TYPE</b>			<input type="checkbox"/> ALM/VYNL				
<input type="checkbox"/> MOBILE HOME			<input type="checkbox"/> CONC BLK				
<input type="checkbox"/> BI/TR LEVEL			<input type="checkbox"/> METAL				
<input type="checkbox"/> MOD/MAN			<input type="checkbox"/> BRICK				
<input type="checkbox"/>			<input type="checkbox"/> STONE				

<b>ROOFING</b>		<b>ROOF TYPE</b>	
<input type="checkbox"/> METAL	<input type="checkbox"/> SLT/TLE	<input type="checkbox"/> SHINGLES	<input type="checkbox"/> SHAKES
<input type="checkbox"/> COMPOSITE	<input type="checkbox"/> GABLE	<input type="checkbox"/> HIP	<input type="checkbox"/> GAMBREL
	<input type="checkbox"/> MANSARD	<input type="checkbox"/> FLAT	

<b>FLOORS</b>	<b>B</b>	<b>1</b>	<b>2</b>	<b>3</b>	<b>U</b>
CONCRETE	<input type="checkbox"/>	<input type="checkbox"/>	<input type="checkbox"/>	<input type="checkbox"/>	<input type="checkbox"/>
WOOD	<input type="checkbox"/>	<input type="checkbox"/>	<input type="checkbox"/>	<input type="checkbox"/>	<input type="checkbox"/>
TILE/COMPO	<input type="checkbox"/>	<input type="checkbox"/>	<input type="checkbox"/>	<input type="checkbox"/>	<input type="checkbox"/>
CARPET	<input type="checkbox"/>	<input type="checkbox"/>	<input type="checkbox"/>	<input type="checkbox"/>	<input type="checkbox"/>

<b>INT. FINISH</b>	<b>B</b>	<b>1</b>	<b>2</b>	<b>3</b>	<b>U</b>
PLASTER/DW	<input type="checkbox"/>	<input type="checkbox"/>	<input type="checkbox"/>	<input type="checkbox"/>	<input type="checkbox"/>
PANELING	<input type="checkbox"/>	<input type="checkbox"/>	<input type="checkbox"/>	<input type="checkbox"/>	<input type="checkbox"/>
UNFINISHED	<input type="checkbox"/>	<input type="checkbox"/>	<input type="checkbox"/>	<input type="checkbox"/>	<input type="checkbox"/>

<b>ACCOMMODATIONS</b>					
# OF ROOMS					
BEDROOMS					
FIREPLACES					
HEAT & AC	<b>B</b>	<b>1</b>	<b>2</b>	<b>3</b>	<b>U</b>
NO HEAT	<input type="checkbox"/>	<input type="checkbox"/>	<input type="checkbox"/>	<input type="checkbox"/>	<input type="checkbox"/>
CTRL HEAT	<input type="checkbox"/>	<input type="checkbox"/>	<input type="checkbox"/>	<input type="checkbox"/>	<input type="checkbox"/>
HW/STEAM	<input type="checkbox"/>	<input type="checkbox"/>	<input type="checkbox"/>	<input type="checkbox"/>	<input type="checkbox"/>
ELECTRIC	<input type="checkbox"/>	<input type="checkbox"/>	<input type="checkbox"/>	<input type="checkbox"/>	<input type="checkbox"/>
HEAT PUMP	<input type="checkbox"/>	<input type="checkbox"/>	<input type="checkbox"/>	<input type="checkbox"/>	<input type="checkbox"/>
FLR/WALL	<input type="checkbox"/>	<input type="checkbox"/>	<input type="checkbox"/>	<input type="checkbox"/>	<input type="checkbox"/>
STVE/SPCE	<input type="checkbox"/>	<input type="checkbox"/>	<input type="checkbox"/>	<input type="checkbox"/>	<input type="checkbox"/>
GEO THERMAL	<input type="checkbox"/>	<input type="checkbox"/>	<input type="checkbox"/>	<input type="checkbox"/>	<input type="checkbox"/>
OUTSIDE	<input type="checkbox"/>	<input type="checkbox"/>	<input type="checkbox"/>	<input type="checkbox"/>	<input type="checkbox"/>
CTRL A/C	<input type="checkbox"/>	<input type="checkbox"/>	<input type="checkbox"/>	<input type="checkbox"/>	<input type="checkbox"/>
PLUMBING		<b>BASE</b> <input type="checkbox"/>			
X FULL BATH					
X HALF BATH					
X FIXTURES					

<b>SUBTOTAL</b>		0
MULTI-FAMILY #	0	0
BUILDING TYPE	000%	0
BSMT FINISH	0 S.F.	0
FIREPLACE #	0	0
HEATING	0 S.F.	0
AIR COND	0 S.F.	0
PLUMBING #	0	0
GARAGES & CARPORTS		0
EXTRA FEATURES		0
<b>SUBTOTAL</b>		0
GRADE FACTOR		%
<b>UNADJUSTED VALUE</b>		0
FACTOR		%

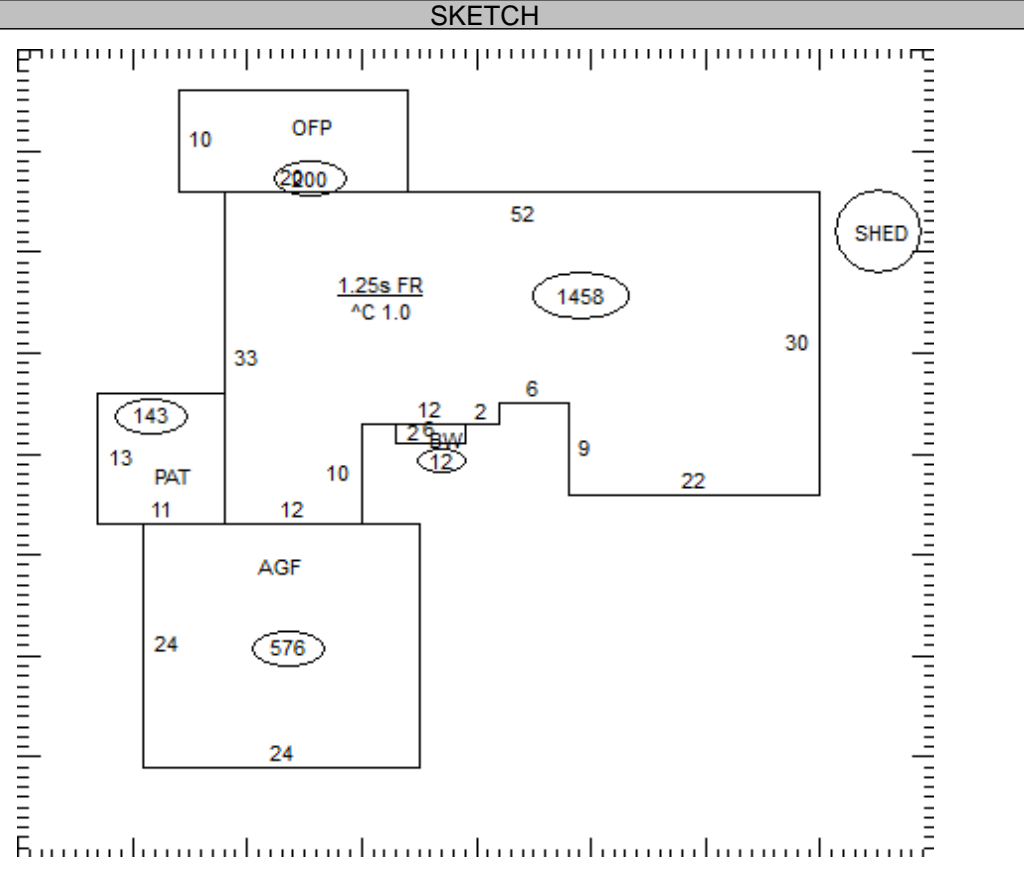

OCCUPANCY	ST.HT	SIZE	AREA	GRADE	PRICE	AGE	REMD	CND	UNADJ VAL	PHYS	PHYS VAL	FUNC	TRUE VAL
DWELLING		SK											
1													
2													
3													
4													
5													
6													
7													
8													
9													
10													
11													

27-461200.0000

TOTAL 0

COMMENTS