

JEFFERSON TWP-CELINA CORP / CELINA SD

06-31-326-008

Property Class: 510

Neighborhood

27502717-02 -

Map: 02

Block: 07

Card: 08

Bk: Pg:

27-390200.0000

SCHMITT CODY S & MILLER EDNA M

SCHMITT CODY S & MILLER EDNA M

1018 HEMLOCK ST

CELINA, OH 45822

LEGAL INFORMATION

KESSLER ADD

LOT#: 42

	OWNERSHIP	ADDRESS	CITY	STATE	ZIP	DATE	AMOUNT	DEED:CONV#	JS	VALID
1	SCHMITT CODY S & MILLER	1018 HEMLOCK ST	CELINA	OH	45822	12/31/2020	148,000	WDC : 989	<input type="checkbox"/>	<input checked="" type="checkbox"/>
2	SMITH BRANDON M	1018 HEMLOCK ST	CELINA	OH	45822	07/16/2020	0	QCE : X : 0	<input type="checkbox"/>	<input type="checkbox"/>
3	SMITH DAVID J	125 MALLARD COVE	CELINA	OH	45822	08/16/2017	127,000	WDC : 545	<input type="checkbox"/>	<input checked="" type="checkbox"/>

X: TTO LISTER: DATE: 08/18/2009 TIME: 12:00:00 AM LETTER LETTER REC'D GIS CODE

STREET/ROAD	TOPOGRAPHY	PU-UTILITIES-PR	NEIGHBORHOOD	INFLUENCE FACTORS	PROPERTY LOCATION	
<input checked="" type="checkbox"/> PAVED <input type="checkbox"/> GRAVEL <input type="checkbox"/> DIRT <input checked="" type="checkbox"/> SIDEWALKS <input type="checkbox"/> CURBS	<input checked="" type="checkbox"/> LEVEL <input type="checkbox"/> HIGH <input type="checkbox"/> LOW <input type="checkbox"/> ROLLING <input type="checkbox"/> STANDARD	<input type="checkbox"/> WATER <input type="checkbox"/> SEWER <input type="checkbox"/> GAS <input type="checkbox"/> ELECTRIC <input checked="" type="checkbox"/> STANDARD	<input type="checkbox"/> IMPROVING <input checked="" type="checkbox"/> STATIC <input type="checkbox"/> DECLINING <input type="checkbox"/> OLD <input type="checkbox"/> STANDARD	<input type="checkbox"/> A. NO ROAD <input type="checkbox"/> B. TOPGRHY <input type="checkbox"/> C. Ex Front <input type="checkbox"/> D. QUANTITY <input type="checkbox"/> E. SZ/SHAPE	<input type="checkbox"/> F. RESTRICT <input type="checkbox"/> G. WOOD LT <input type="checkbox"/> H. VACANCY <input type="checkbox"/> I. WATER FRONT <input type="checkbox"/> J. OTHER/CDU	1018 HEMLOCK ST, CELINA COMMENT TY2022:Net Gen=\$2,000.50, Other Assessment=\$0.00 DE15 CORR FIN BSMNT AREA AND PLMNG PER DATA MAILER DE11 ADD CAN DE09 ADD CENTRAL AC & 2 ADDTL'FIX PER DATA MAILER DE19 REMOVE OWN OCC. Owner didn't ret app

LAND COMPUTATIONS

LAND TYPE	SIZE	M	RATE	C	INF	M	VALUE	C
F:Front	F58 D109	ST395	DP85	ADJ336			19,500	0
TOTAL							19,500	0

VALUATION SUMMARY

VALUE YEAR	2023	2020	2017				
REASON FOR CHANGE	RAPP	RAPP	RAPP				
APPRAISED VALUE	<u>LAND</u> 19,500	12,400	10,800				
	<u>IMPR</u> 137,500	111,400	93,700				
	<u>TOTAL</u> 157,000	123,800	104,500				
ASSESSED VALUE	<u>LAND</u> 6,830	4,340	3,780				
	<u>IMPR</u> 48,130	38,990	32,800				
	<u>TOTAL</u> 54,960	43,330	36,580				

OCCUPANCY		EXTERIOR		FLOOR	AREA	CONST	VALUE
<input checked="" type="checkbox"/> SF <input type="checkbox"/> DU <input type="checkbox"/> TR		<input type="checkbox"/> WOOD		1	1338	FR	191,280
<input type="checkbox"/> CONVERSION		<input type="checkbox"/> STUCCO					
BUILDING TYPE		<input checked="" type="checkbox"/> ALM/VYNL					
<input type="checkbox"/> MOBILE HOME		<input type="checkbox"/> CONC BLK					
<input type="checkbox"/> BI/TR LEVEL		<input type="checkbox"/> METAL					
<input type="checkbox"/> MOD/MAN		<input type="checkbox"/> BRICK					
<input type="checkbox"/>		<input type="checkbox"/> STONE					
ROOFING		ROOF TYPE					
<input type="checkbox"/> METAL		<input checked="" type="checkbox"/> GABLE					
<input type="checkbox"/> SLT/TLE		<input type="checkbox"/> HIP					
<input checked="" type="checkbox"/> SHINGLES		<input type="checkbox"/> GAMBREL					
<input type="checkbox"/> SHAKES		<input type="checkbox"/> MANSARD					
<input type="checkbox"/> COMPOSITE		<input type="checkbox"/> FLAT					

BSMT	1338		19,130
SUBTOTAL			210,410
MULTI-FAMILY #	0		0
BUILDING TYPE	100%		0
BSMT FINISH	669 S.F.		9,570
FIREPLACE #	2		8,800
HEATING	0 S.F.		0
AIR COND	1,338 S.F.		2,210
PLUMBING #	3		3,630
GARAGES & CARPORTS			1,600
EXTRA FEATURES			900
SUBTOTAL			237,120
GRADE FACTOR			100 %
UNADJUSTED VALUE			237,120
FACTOR			100 %

FLOORS		B	1	2	3	U
CONCRETE	<input type="checkbox"/>	<input type="checkbox"/>	<input type="checkbox"/>	<input type="checkbox"/>	<input type="checkbox"/>	<input type="checkbox"/>
WOOD	<input type="checkbox"/>	<input type="checkbox"/>	<input type="checkbox"/>	<input type="checkbox"/>	<input type="checkbox"/>	<input type="checkbox"/>
TILE/COMPO	<input type="checkbox"/>	<input checked="" type="checkbox"/>	<input type="checkbox"/>	<input type="checkbox"/>	<input type="checkbox"/>	<input type="checkbox"/>
CARPET	<input checked="" type="checkbox"/>	<input checked="" type="checkbox"/>	<input type="checkbox"/>	<input type="checkbox"/>	<input type="checkbox"/>	<input type="checkbox"/>
INT. FINISH		B	1	2	3	U
PLASTER/DW	<input type="checkbox"/>	<input checked="" type="checkbox"/>	<input type="checkbox"/>	<input type="checkbox"/>	<input type="checkbox"/>	<input type="checkbox"/>
PANELING	<input checked="" type="checkbox"/>	<input type="checkbox"/>	<input type="checkbox"/>	<input type="checkbox"/>	<input type="checkbox"/>	<input type="checkbox"/>
UNFINISHED	<input type="checkbox"/>	<input type="checkbox"/>	<input type="checkbox"/>	<input type="checkbox"/>	<input type="checkbox"/>	<input type="checkbox"/>
ACCOMMODATIONS						
# OF ROOMS		5				
BEDROOMS		3				
FIREPLACES		2				
HEAT & AC		B	1	2	3	U
NO HEAT	<input type="checkbox"/>	<input type="checkbox"/>	<input type="checkbox"/>	<input type="checkbox"/>	<input type="checkbox"/>	<input type="checkbox"/>
CTRL HEAT	<input checked="" type="checkbox"/>	<input checked="" type="checkbox"/>	<input type="checkbox"/>	<input type="checkbox"/>	<input type="checkbox"/>	<input type="checkbox"/>
HW/STEAM	<input type="checkbox"/>	<input type="checkbox"/>	<input type="checkbox"/>	<input type="checkbox"/>	<input type="checkbox"/>	<input type="checkbox"/>
ELECTRIC	<input type="checkbox"/>	<input type="checkbox"/>	<input type="checkbox"/>	<input type="checkbox"/>	<input type="checkbox"/>	<input type="checkbox"/>
HEAT PUMP	<input type="checkbox"/>	<input type="checkbox"/>	<input type="checkbox"/>	<input type="checkbox"/>	<input type="checkbox"/>	<input type="checkbox"/>
FLR/WALL	<input type="checkbox"/>	<input type="checkbox"/>	<input type="checkbox"/>	<input type="checkbox"/>	<input type="checkbox"/>	<input type="checkbox"/>
STVE/SPCE	<input type="checkbox"/>	<input type="checkbox"/>	<input type="checkbox"/>	<input type="checkbox"/>	<input type="checkbox"/>	<input type="checkbox"/>
GEOTHERMAL	<input type="checkbox"/>	<input type="checkbox"/>	<input type="checkbox"/>	<input type="checkbox"/>	<input type="checkbox"/>	<input type="checkbox"/>
OUTSIDE	<input type="checkbox"/>	<input type="checkbox"/>	<input type="checkbox"/>	<input type="checkbox"/>	<input type="checkbox"/>	<input type="checkbox"/>
CTRL A/C	<input type="checkbox"/>	<input checked="" type="checkbox"/>	<input type="checkbox"/>	<input type="checkbox"/>	<input type="checkbox"/>	<input type="checkbox"/>
PLUMBING		BASE	<input checked="" type="checkbox"/>			
X FULL BATH		1				
X HALF BATH						
X FIXTURES						

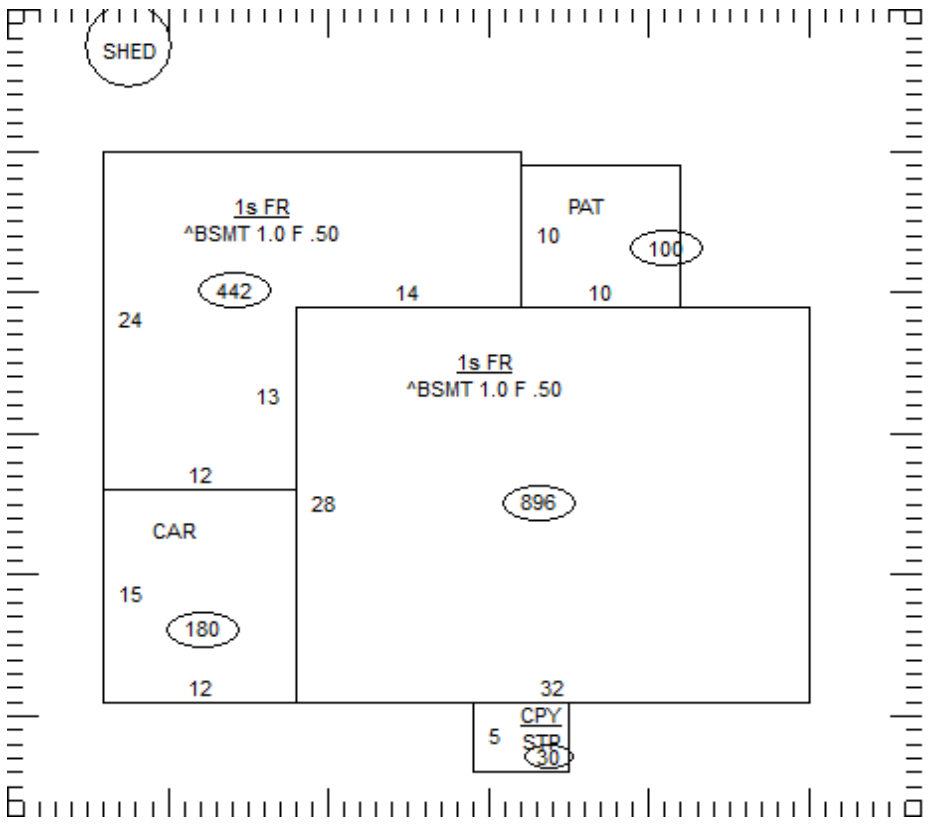

OCCUPANCY	ST.HT	SIZE	AREA	GRADE	PRICE	AGE	REMD	CND	UNADJ VAL	PHYS	PHYS VAL	FUNC	TRUE VAL
DWELLING	1	SK	1,338	C		1958		A	237,120	42	137,530		137,500
1 Shed		10x12	120	C		2000		A		37			0
2													
3													
4													
5													
6													
7													
8													
9													
10													
11													

27-390200.0000

TOTAL 137,500

COMMENTS
 Dwelling has an Economic Factor of 100%

JEFFERSON TWP-CELINA CORP / CELINA SD

06-31-326-008

Property Class: 510

Neighborhood

27502717-02 -

Map: 02

Block: 07

Card: 08

Bk: Pg:

27-390200.0000

SCHMITT CODY S & MILLER EDNA M

SCHMITT CODY S & MILLER EDNA M

1018 HEMLOCK ST

CELINA, OH 45822

LEGAL INFORMATION

KESSLER ADD

LOT#: 42

	OWNERSHIP	ADDRESS	CITY	STATE	ZIP	DATE	AMOUNT	DEED:CONV#	JS	VALID
1	CRON ADAM J	1018 HEMLOCK ST	CELINA	OH	45822	04/09/2014	84,900	WDC : 180	<input type="checkbox"/>	<input type="checkbox"/>
2	KRIEGEL MARY A	1018 HEMLOCK	CELINA	OH	45822	04/30/2010	0	QCE : X : 0	<input type="checkbox"/>	<input type="checkbox"/>
3	KRIEGEL EDWARD J & MARY A	1018 HEMLOCK ST	CELINA	OH	45822		0	: 0	<input type="checkbox"/>	<input type="checkbox"/>

X: TTO LISTER: DATE: 08/18/2009 TIME: 12:00:00 AM LETTER LETTER REC'D GIS CODE

STREET/ROAD **TOPOGRAPHY** **PU-UTILITIES-PR** **NEIGHBORHOOD** **INFLUENCE FACTORS** **PROPERTY LOCATION**

<input checked="" type="checkbox"/> PAVED	<input checked="" type="checkbox"/> LEVEL	<input type="checkbox"/> WATER	<input type="checkbox"/> IMPROVING	<input type="checkbox"/> A. NO ROAD	<input type="checkbox"/> F. RESTRICT	1018 HEMLOCK ST, CELINA COMMENT
<input type="checkbox"/> GRAVEL	<input type="checkbox"/> HIGH	<input type="checkbox"/> SEWER	<input checked="" type="checkbox"/> STATIC	<input type="checkbox"/> B. TOPGRHY	<input type="checkbox"/> G. WOOD LT	
<input type="checkbox"/> DIRT	<input type="checkbox"/> LOW	<input type="checkbox"/> GAS	<input type="checkbox"/> DECLINING	<input type="checkbox"/> C. Ex Front	<input type="checkbox"/> H. VACANCY	
<input checked="" type="checkbox"/> SIDEWALKS	<input type="checkbox"/> ROLLING	<input type="checkbox"/> ELECTRIC	<input type="checkbox"/> OLD	<input type="checkbox"/> D. QUANTITY	<input type="checkbox"/> I. WATER FRONT	
<input type="checkbox"/> CURBS	<input type="checkbox"/> STANDARD	<input checked="" type="checkbox"/> STANDARD	<input type="checkbox"/> STANDARD	<input type="checkbox"/> E. SZ/SHAPE	<input type="checkbox"/> J. OTHER/CDU	

LAND COMPUTATIONS

LAND TYPE	SIZE	M	RATE	C	INF	M	VALUE	C
TOTAL							19,500	0

VALUATION SUMMARY

VALUE YEAR								
REASON FOR CHANGE								
APPRaised	<u>LAND</u>							
VALUE	<u>IMPR</u>							
	<u>TOTAL</u>							
ASSESSed	<u>LAND</u>							
VALUE	<u>IMPR</u>							
	<u>TOTAL</u>							

