

OCCUPANCY		EXTERIOR		FLOOR	AREA	CONST	VALUE
<input checked="" type="checkbox"/> SF	<input type="checkbox"/> DU	<input type="checkbox"/> TR	<input type="checkbox"/> WOOD	1	1156	FR	174,170
<input type="checkbox"/> CONVERSION			<input type="checkbox"/> STUCCO	.5	140	FR	13,080
BUILDING TYPE		<input checked="" type="checkbox"/> ALM/VYNL					
<input type="checkbox"/> MOBILE HOME			<input type="checkbox"/> CONC BLK				
<input type="checkbox"/> BI/TR LEVEL			<input type="checkbox"/> METAL				
<input type="checkbox"/> MOD/MAN			<input type="checkbox"/> BRICK				
<input type="checkbox"/>			<input type="checkbox"/> STONE				

ROOFING		ROOF TYPE	
<input type="checkbox"/> METAL			<input checked="" type="checkbox"/> GABLE
<input type="checkbox"/> SLT/TLE			<input type="checkbox"/> HIP
<input checked="" type="checkbox"/> SHINGLES			<input type="checkbox"/> GAMBREL
<input type="checkbox"/> SHAKES			<input type="checkbox"/> MANSARD
<input type="checkbox"/> COMPOSITE			<input type="checkbox"/> FLAT

SUBTOTAL				187,250
MULTI-FAMILY #		0		0
BUILDING TYPE		100%		0
BSMT FINISH		0 S.F.		0
FIREPLACE #		0		0
HEATING		140 S.F.		-530
AIR COND		1,156 S.F.		1,910
PLUMBING #		3		3,630
GARAGES & CARPORTS				0
EXTRA FEATURES				2,600
SUBTOTAL				194,860
GRADE FACTOR				100 %
UNADJUSTED VALUE				194,860
FACTOR				100 %

FLOORS		B	1	2	3	U
CONCRETE		<input type="checkbox"/>	<input type="checkbox"/>	<input type="checkbox"/>	<input type="checkbox"/>	<input type="checkbox"/>
WOOD		<input type="checkbox"/>	<input type="checkbox"/>	<input type="checkbox"/>	<input type="checkbox"/>	<input type="checkbox"/>
TILE/COMPO		<input type="checkbox"/>	<input checked="" type="checkbox"/>	<input checked="" type="checkbox"/>	<input type="checkbox"/>	<input type="checkbox"/>
CARPET		<input type="checkbox"/>	<input checked="" type="checkbox"/>	<input checked="" type="checkbox"/>	<input type="checkbox"/>	<input type="checkbox"/>
INT. FINISH		B	1	2	3	U
PLASTER/DW		<input type="checkbox"/>	<input checked="" type="checkbox"/>	<input checked="" type="checkbox"/>	<input type="checkbox"/>	<input type="checkbox"/>
PANELING		<input type="checkbox"/>	<input checked="" type="checkbox"/>	<input checked="" type="checkbox"/>	<input type="checkbox"/>	<input type="checkbox"/>
UNFINISHED		<input type="checkbox"/>	<input type="checkbox"/>	<input type="checkbox"/>	<input type="checkbox"/>	<input type="checkbox"/>
ACCOMMODATIONS						
# OF ROOMS			5	2		
BEDROOMS			2	2		
FIREPLACES						
HEAT & AC		B	1	2	3	U
NO HEAT		<input type="checkbox"/>	<input type="checkbox"/>	<input checked="" type="checkbox"/>	<input type="checkbox"/>	<input type="checkbox"/>
CTRL HEAT		<input type="checkbox"/>	<input checked="" type="checkbox"/>	<input type="checkbox"/>	<input type="checkbox"/>	<input type="checkbox"/>
HW/STEAM		<input type="checkbox"/>	<input type="checkbox"/>	<input type="checkbox"/>	<input type="checkbox"/>	<input type="checkbox"/>
ELECTRIC		<input type="checkbox"/>	<input type="checkbox"/>	<input type="checkbox"/>	<input type="checkbox"/>	<input type="checkbox"/>
HEAT PUMP		<input type="checkbox"/>	<input type="checkbox"/>	<input type="checkbox"/>	<input type="checkbox"/>	<input type="checkbox"/>
FLR/WALL		<input type="checkbox"/>	<input type="checkbox"/>	<input checked="" type="checkbox"/>	<input type="checkbox"/>	<input type="checkbox"/>
STVE/SPCE		<input type="checkbox"/>	<input type="checkbox"/>	<input type="checkbox"/>	<input type="checkbox"/>	<input type="checkbox"/>
GEO THERMAL		<input type="checkbox"/>	<input type="checkbox"/>	<input type="checkbox"/>	<input type="checkbox"/>	<input type="checkbox"/>
OUTSIDE		<input type="checkbox"/>	<input type="checkbox"/>	<input type="checkbox"/>	<input type="checkbox"/>	<input type="checkbox"/>
CTRL A/C		<input type="checkbox"/>	<input checked="" type="checkbox"/>	<input type="checkbox"/>	<input type="checkbox"/>	<input type="checkbox"/>
PLUMBING		BASE		<input checked="" type="checkbox"/>		
X FULL BATH			1			
X HALF BATH						
X FIXTURES						

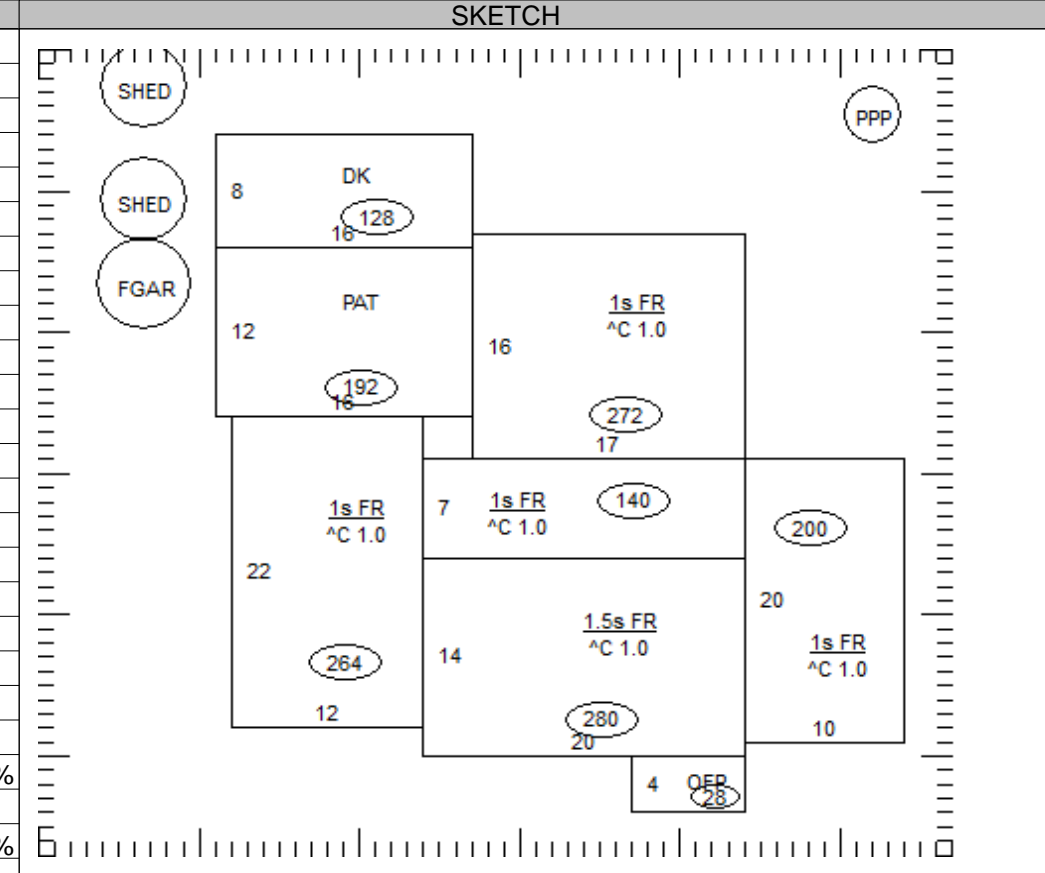

OCCUPANCY	ST.HT	SIZE	AREA	GRADE	PRICE	AGE	REMD	CND	UNADJ VAL	PHYS	PHYS VAL	FUNC	TRUE VAL
DWELLING	1.5	SK	1,296	C		1952		A	194,860	45	107,170		101,800
1 Gar - Frame		24x24	576	C	23.70	1982		A	13,650	77	3,140		3,100
2 Pool - PP		20x20	400	C		2020		A		3			0
3 Shed		10x16	160	C	9.90	2020		A	1,580	3	1,530		1,500
4 Shed		8x16	128	C		2020		A		3			0
5													
6													
7													
8													
9													
10													
11													

27-339800.0000	TOTAL	106,400
----------------	-------	---------

COMMENTS

Dwelling has an Economic Factor of 95% (Rollback Basis=\$140,700)

