



27-317100.0000

JEFFERSON TWP-CELINA CORP / CELINA SD

05-36-480-012

Page 1 of 2
Property Class: 510
Neighborhood
27502703-01 -
Map: 01 I
Block:
Card: 71
Bk: Pg:

HOLT BARBARA A
HOLT BARBARA A
509 N WALNUT ST
CELINA, OH 45822

LEGAL INFORMATION
SCHUNCKS ADD

LOT#: 8

	OWNERSHIP	ADDRESS	CITY	STATE	ZIP	DATE	AMOUNT	DEED:CONV#	JS	VALID
1	HOLT BARBARA A	509 N WALNUT ST	CELINA	OH	45822	11/05/2019	126,000	WDC : 762	<input type="checkbox"/>	<input checked="" type="checkbox"/>
2	SKAPURA DAVID C &	509 WALNUT ST	CELINA	OH	45822	07/18/2014	34,600	WDC : 446	<input type="checkbox"/>	<input checked="" type="checkbox"/>
3	POST ANNETTA M	3150 FT RECOVERY	SAINT HENRY	OH	45883	05/25/2011	31,900	WDC : E : 257	<input type="checkbox"/>	<input type="checkbox"/>

X: TTO LISTER: DF DATE: 05/17/2005 TIME: 11:27:15 AM LETTER LETTER REC'D GIS CODE

STREET/ROAD	TOPOGRAPHY	PU-UTILITIES-PR	NEIGHBORHOOD	INFLUENCE FACTORS				PROPERTY LOCATION
<input checked="" type="checkbox"/> PAVED	<input checked="" type="checkbox"/> LEVEL	<input type="checkbox"/> WATER <input type="checkbox"/>	<input type="checkbox"/> IMPROVING	<input type="checkbox"/> A. NO ROAD	<input type="checkbox"/> F. RESTRICT	509 N WALNUT ST, CELINA		
<input type="checkbox"/> GRAVEL	<input type="checkbox"/> HIGH	<input type="checkbox"/> SEWER <input type="checkbox"/>	<input checked="" type="checkbox"/> STATIC	<input type="checkbox"/> B. TOPGRHY	<input type="checkbox"/> G. WOOD LT	COMMENT		
<input type="checkbox"/> DIRT	<input type="checkbox"/> LOW	<input type="checkbox"/> GAS <input type="checkbox"/>	<input type="checkbox"/> DECLINING	<input type="checkbox"/> C. Ex Front	<input type="checkbox"/> H. VACANCY	TY2022:Net Gen=\$1,331.32, Other		
<input checked="" type="checkbox"/> SIDEWALKS	<input type="checkbox"/> ROLLING	<input type="checkbox"/> ELECTRIC <input type="checkbox"/>	<input type="checkbox"/> OLD	<input type="checkbox"/> D. QUANTITY	<input type="checkbox"/> I. WATER FRONT	Assessment=\$0.00		
<input type="checkbox"/> CURBS	<input type="checkbox"/> STANDARD	<input checked="" type="checkbox"/> STANDARD	<input type="checkbox"/> STANDARD	<input type="checkbox"/> E. SZ/SHAPE	<input type="checkbox"/> J. OTHER/CDU	DE16 DESKTOP RVW CHG: rmv cpy		

LAND COMPUTATIONS

LAND TYPE	SIZE	M	RATE	C	INF	M	VALUE	C
F:Front	F66 D165	ST350	DP105	ADJ368			24,300	0
					TOTAL		24,300	0

VALUATION SUMMARY

VALUE YEAR	2023	2022	2021	2020	2017	2005	2005	2005
REASON FOR CHANGE	RAPP	MISC	MISC	RAPP	RAPP	RAPP	RAPP	RAPP
APPRAISED VALUE	LAND 24,300	14,300	14,300	14,300	13,200	15,600	15,600	15,600
	IMPR 108,700	69,900	69,400	67,700	57,200	41,800	41,800	41,800
	TOTAL 133,000	84,200	83,700	82,000	70,400	57,400	57,400	57,400
ASSESSED VALUE	LAND 8,510	5,010	5,010	5,010	4,620	5,460	5,460	5,460
	IMPR 38,050	24,470	24,290	23,700	20,020	14,630	14,630	14,630
	TOTAL 46,560	29,480	29,300	28,710	24,640	20,090	20,090	20,090

OCCUPANCY		EXTERIOR		FLOOR	AREA	CONST	VALUE						
<input checked="" type="checkbox"/> SF	<input type="checkbox"/> DU	<input type="checkbox"/> TR	<input type="checkbox"/> WOOD	1	1104	FR	169,270						
<input type="checkbox"/> CONVERSION	<input type="checkbox"/> STUCCO			.5	380	FR	36,120						
BUILDING TYPE		<input checked="" type="checkbox"/> ALM/VYNL											
<input type="checkbox"/> MOBILE HOME	<input type="checkbox"/> CONC BLK												
<input type="checkbox"/> BI/TR LEVEL	<input type="checkbox"/> METAL												
<input type="checkbox"/> MOD/MAN	<input type="checkbox"/> BRICK												
<input type="checkbox"/>	<input type="checkbox"/> STONE												
ROOFING		ROOF TYPE											
<input type="checkbox"/> METAL	<input checked="" type="checkbox"/> GABLE												
<input type="checkbox"/> SLT/TLE	<input type="checkbox"/> HIP												
<input checked="" type="checkbox"/> SHINGLES	<input type="checkbox"/> GAMBREL												
<input type="checkbox"/> SHAKES	<input type="checkbox"/> MANSARD												
<input type="checkbox"/> COMPOSITE	<input type="checkbox"/> FLAT												
FLOORS		B	1	2	3	U							
CONCRETE	<input type="checkbox"/>	<input type="checkbox"/>	<input type="checkbox"/>	<input type="checkbox"/>	<input type="checkbox"/>	<input type="checkbox"/>							
WOOD	<input type="checkbox"/>	<input checked="" type="checkbox"/>	<input checked="" type="checkbox"/>	<input type="checkbox"/>	<input type="checkbox"/>	<input type="checkbox"/>							
TILE/COMPO	<input type="checkbox"/>	<input type="checkbox"/>	<input type="checkbox"/>	<input type="checkbox"/>	<input type="checkbox"/>	<input type="checkbox"/>							
CARPET	<input type="checkbox"/>	<input checked="" type="checkbox"/>	<input checked="" type="checkbox"/>	<input type="checkbox"/>	<input type="checkbox"/>	<input type="checkbox"/>							
INT. FINISH		B	1	2	3	U							
PLASTER/DW	<input type="checkbox"/>	<input checked="" type="checkbox"/>	<input checked="" type="checkbox"/>	<input type="checkbox"/>	<input type="checkbox"/>	<input type="checkbox"/>							
PANELING	<input type="checkbox"/>	<input checked="" type="checkbox"/>	<input checked="" type="checkbox"/>	<input type="checkbox"/>	<input type="checkbox"/>	<input type="checkbox"/>							
UNFINISHED	<input type="checkbox"/>	<input type="checkbox"/>	<input type="checkbox"/>	<input type="checkbox"/>	<input type="checkbox"/>	<input type="checkbox"/>							
ACCOMMODATIONS													
# OF ROOMS		4	3										
BEDROOMS		1	3										
FIREPLACES													
HEAT & AC		B	1	2	3	U							
NO HEAT	<input type="checkbox"/>	<input type="checkbox"/>	<input checked="" type="checkbox"/>	<input type="checkbox"/>	<input type="checkbox"/>	<input type="checkbox"/>							
CTRL HEAT	<input type="checkbox"/>	<input checked="" type="checkbox"/>	<input type="checkbox"/>	<input type="checkbox"/>	<input type="checkbox"/>	<input type="checkbox"/>							
HW/STEAM	<input type="checkbox"/>	<input checked="" type="checkbox"/>	<input type="checkbox"/>	<input type="checkbox"/>	<input type="checkbox"/>	<input type="checkbox"/>							
ELECTRIC	<input type="checkbox"/>	<input type="checkbox"/>	<input type="checkbox"/>	<input type="checkbox"/>	<input type="checkbox"/>	<input type="checkbox"/>							
HEAT PUMP	<input type="checkbox"/>	<input type="checkbox"/>	<input type="checkbox"/>	<input type="checkbox"/>	<input type="checkbox"/>	<input type="checkbox"/>							
FLR/WALL	<input type="checkbox"/>	<input type="checkbox"/>	<input type="checkbox"/>	<input type="checkbox"/>	<input type="checkbox"/>	<input type="checkbox"/>							
STVE/SPCE	<input type="checkbox"/>	<input type="checkbox"/>	<input type="checkbox"/>	<input type="checkbox"/>	<input type="checkbox"/>	<input type="checkbox"/>							
GEO THERMAL	<input type="checkbox"/>	<input type="checkbox"/>	<input type="checkbox"/>	<input type="checkbox"/>	<input type="checkbox"/>	<input type="checkbox"/>							
OUTSIDE	<input type="checkbox"/>	<input type="checkbox"/>	<input type="checkbox"/>	<input type="checkbox"/>	<input type="checkbox"/>	<input type="checkbox"/>							
CTRL A/C	<input type="checkbox"/>	<input type="checkbox"/>	<input type="checkbox"/>	<input type="checkbox"/>	<input type="checkbox"/>	<input type="checkbox"/>							
PLUMBING		BASE		<input checked="" type="checkbox"/>									
X FULL BATH		1											
X HALF BATH													
X FIXTURES													
SUBTOTAL							205,390						
MULTI-FAMILY #	0						0						
BUILDING TYPE	100%						0						
BSMT FINISH	0 S.F.						0						
FIREPLACE #	0						0						
HEATING	380 S.F.						-1,440						
AIR COND	0 S.F.						0						
PLUMBING #	3						3,630						
GARAGES & CARPORTS							0						
EXTRA FEATURES							11,300						
SUBTOTAL							218,880						
GRADE FACTOR							95 %						
UNADJUSTED VALUE							207,940						
FACTOR							100 %						
OCCUPANCY	ST.HT	SIZE	AREA	GRADE	PRICE	AGE	REMD	CND	UNADJ VAL	PHYS	PHYS VAL	FUNC	TRUE VAL
DWELLING	1.5	SK	1,484	C-		1895		A	207,940	45	114,370		108,700
1 Shed		10x14	140	C		1983		A		67			0
2													
3													
4													
5													
6													
7													
8													
9													
10													
11													

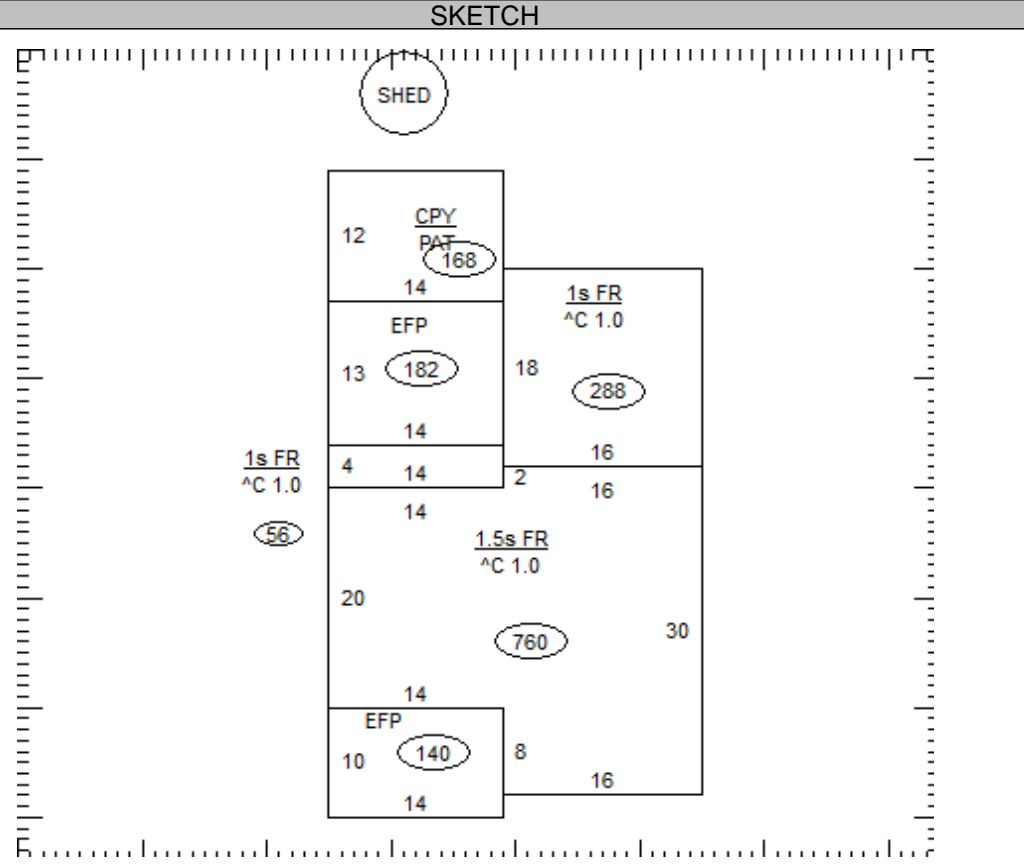

27-317100.0000

TOTAL 108,700

COMMENTS

Dwelling has an Economic Factor of 95%



27-317100.0000

HOLT BARBARA A
HOLT BARBARA A
509 N WALNUT ST
CELINA, OH 45822

JEFFERSON TWP-CELINA CORP / CELINA SD
05-36-480-012

Page 2 of 2
Property Class: 510
Neighborhood
27502703-01 -
Map: 01 I
Block:
Card: 71
Bk: Pg:

LEGAL INFORMATION
SCHUNCKS ADD

LOT#: 8

OWNERSHIP	ADDRESS	CITY	STATE	ZIP	DATE	AMOUNT	DEED:CONV#	JS	VALID
1	WALTER RITA M	509 WALNUT ST	CELINA	OH	45822	08/10/1988	0 : X : 0	<input type="checkbox"/>	<input type="checkbox"/>
2							0 0	<input type="checkbox"/>	<input type="checkbox"/>
3							0 0	<input type="checkbox"/>	<input type="checkbox"/>

X: TTO LISTER: DF DATE: 05/17/2005 TIME: 11:27:15 AM LETTER LETTER REC'D GIS CODE

STREET/ROAD	TOPOGRAPHY	PU-UTILITIES-PR	NEIGHBORHOOD	INFLUENCE FACTORS	PROPERTY LOCATION	
<input checked="" type="checkbox"/> PAVED <input type="checkbox"/> GRAVEL <input type="checkbox"/> DIRT <input checked="" type="checkbox"/> SIDEWALKS <input type="checkbox"/> CURBS	<input checked="" type="checkbox"/> LEVEL <input type="checkbox"/> HIGH <input type="checkbox"/> LOW <input type="checkbox"/> ROLLING <input type="checkbox"/> STANDARD	<input type="checkbox"/> WATER <input type="checkbox"/> SEWER <input type="checkbox"/> GAS <input type="checkbox"/> ELECTRIC <input checked="" type="checkbox"/> STANDARD	<input type="checkbox"/> IMPROVING <input checked="" type="checkbox"/> STATIC <input type="checkbox"/> DECLINING <input type="checkbox"/> OLD <input type="checkbox"/> STANDARD	<input type="checkbox"/> A. NO ROAD <input type="checkbox"/> B. TOPGRHY <input type="checkbox"/> C. Ex Front <input type="checkbox"/> D. QUANTITY <input type="checkbox"/> E. SZ/SHAPE	<input type="checkbox"/> F. RESTRICT <input type="checkbox"/> G. WOOD LT <input type="checkbox"/> H. VACANCY <input type="checkbox"/> I. WATER FRONT <input type="checkbox"/> J. OTHER/CDU	509 N WALNUT ST, CELINA COMMENT

LAND COMPUTATIONS							
LAND TYPE	SIZE	M	RATE	C	INF	M	VALUE C
TOTAL						24,300	0

VALUATION SUMMARY							
VALUE YEAR	2005	2005	2004				
REASON FOR CHANGE	RAPP	REVAL	2004				
APPRaised	LAND	15,600	15,600	13,860			
VALUE	IMPR	41,800	41,800	38,630			
	TOTAL	57,400	57,400	52,490			
ASSESSED	LAND	5,460	5,460	4,850			
VALUE	IMPR	14,630	14,630	13,520			
	TOTAL	20,090	20,090	18,370			

OCCUPANCY		EXTERIOR		FLOOR	AREA	CONST	VALUE						
<input type="checkbox"/> SF	<input type="checkbox"/> DU	<input type="checkbox"/> TR	<input type="checkbox"/> WOOD										
<input type="checkbox"/> CONVERSION		<input type="checkbox"/> STUCCO											
BUILDING TYPE		<input type="checkbox"/> ALM/VYNL											
<input type="checkbox"/> MOBILE HOME		<input type="checkbox"/> CONC BLK											
<input type="checkbox"/> BI/TR LEVEL		<input type="checkbox"/> METAL											
<input type="checkbox"/> MOD/MAN		<input type="checkbox"/> BRICK											
<input type="checkbox"/> _____		<input type="checkbox"/> STONE											
ROOFING		ROOF TYPE											
<input type="checkbox"/> METAL		<input type="checkbox"/> GABLE											
<input type="checkbox"/> SLT/TLE		<input type="checkbox"/> HIP											
<input type="checkbox"/> SHINGLES		<input type="checkbox"/> GAMBREL											
<input type="checkbox"/> SHAKES		<input type="checkbox"/> MANSARD											
<input type="checkbox"/> COMPOSITE		<input type="checkbox"/> FLAT											
FLOORS		B	1	2	3	U							
CONCRETE		<input type="checkbox"/>	<input type="checkbox"/>	<input type="checkbox"/>	<input type="checkbox"/>	<input type="checkbox"/>							
WOOD		<input type="checkbox"/>	<input type="checkbox"/>	<input type="checkbox"/>	<input type="checkbox"/>	<input type="checkbox"/>							
TILE/COMPO		<input type="checkbox"/>	<input type="checkbox"/>	<input type="checkbox"/>	<input type="checkbox"/>	<input type="checkbox"/>							
CARPET		<input type="checkbox"/>	<input type="checkbox"/>	<input type="checkbox"/>	<input type="checkbox"/>	<input type="checkbox"/>							
INT. FINISH		B	1	2	3	U							
PLASTER/DW		<input type="checkbox"/>	<input type="checkbox"/>	<input type="checkbox"/>	<input type="checkbox"/>	<input type="checkbox"/>							
PANELING		<input type="checkbox"/>	<input type="checkbox"/>	<input type="checkbox"/>	<input type="checkbox"/>	<input type="checkbox"/>							
UNFINISHED		<input type="checkbox"/>	<input type="checkbox"/>	<input type="checkbox"/>	<input type="checkbox"/>	<input type="checkbox"/>							
ACCOMMODATIONS													
# OF ROOMS													
BEDROOMS													
FIREPLACES													
HEAT & AC		B	1	2	3	U							
NO HEAT		<input type="checkbox"/>	<input type="checkbox"/>	<input type="checkbox"/>	<input type="checkbox"/>	<input type="checkbox"/>							
CTRL HEAT		<input type="checkbox"/>	<input type="checkbox"/>	<input type="checkbox"/>	<input type="checkbox"/>	<input type="checkbox"/>							
HW/STEAM		<input type="checkbox"/>	<input type="checkbox"/>	<input type="checkbox"/>	<input type="checkbox"/>	<input type="checkbox"/>							
ELECTRIC		<input type="checkbox"/>	<input type="checkbox"/>	<input type="checkbox"/>	<input type="checkbox"/>	<input type="checkbox"/>							
HEAT PUMP		<input type="checkbox"/>	<input type="checkbox"/>	<input type="checkbox"/>	<input type="checkbox"/>	<input type="checkbox"/>							
FLR/WALL		<input type="checkbox"/>	<input type="checkbox"/>	<input type="checkbox"/>	<input type="checkbox"/>	<input type="checkbox"/>							
STVE/SPCE		<input type="checkbox"/>	<input type="checkbox"/>	<input type="checkbox"/>	<input type="checkbox"/>	<input type="checkbox"/>							
GEOTHERMAL		<input type="checkbox"/>	<input type="checkbox"/>	<input type="checkbox"/>	<input type="checkbox"/>	<input type="checkbox"/>							
OUTSIDE		<input type="checkbox"/>	<input type="checkbox"/>	<input type="checkbox"/>	<input type="checkbox"/>	<input type="checkbox"/>							
CTRL A/C		<input type="checkbox"/>	<input type="checkbox"/>	<input type="checkbox"/>	<input type="checkbox"/>	<input type="checkbox"/>							
PLUMBING			BASE		<input type="checkbox"/>								
X FULL BATH													
X HALF BATH													
X FIXTURES													
SUBTOTAL							0						
MULTI-FAMILY #	0						0						
BUILDING TYPE	000%						0						
BSMT FINISH	0 S.F.						0						
FIREPLACE #	0						0						
HEATING	0 S.F.						0						
AIR COND	0 S.F.						0						
PLUMBING #	0						0						
GARAGES & CARPORTS							0						
EXTRA FEATURES							0						
SUBTOTAL							0						
GRADE FACTOR							%						
UNADJUSTED VALUE							0						
FACTOR							%						
OCCUPANCY	ST.HT	SIZE	AREA	GRADE	PRICE	AGE	REMD	CND	UNADJ VAL	PHYS	PHYS VAL	FUNC	TRUE VAL
DWELLING		SK											
1													
2													
3													
4													
5													
6													
7													
8													
9													
10													
11													

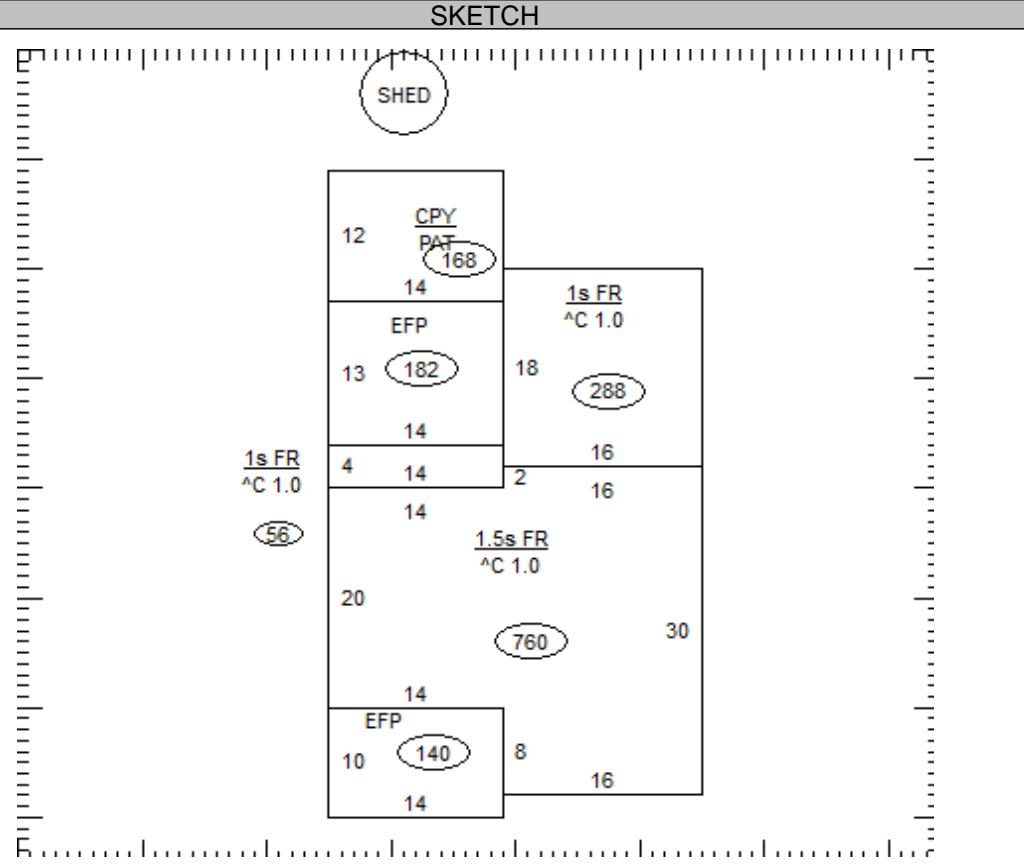

27-317100.0000

TOTAL 0

COMMENTS