



27-211300.0000

JEFFERSON TWP-CELINA CORP / CELINA SD

08-01-453-005

Property Class: 510

Neighborhood
27502702-01 -

Map: 04
Block: 14
Card: 19

Bk: Pg:

LEGAL INFORMATION

MIAMI ADD

LOT#: 49

**QUALIFIED CREDITS:
HOMESTEAD**

	OWNERSHIP	ADDRESS	CITY	STATE	ZIP	DATE	AMOUNT	DEED:CONV#	JS	VALID
1	FETTERS REBECCA L	720 ECHO ST	CELINA	OH	45822	05/02/2023	55,000	WDC : 231	<input type="checkbox"/>	<input checked="" type="checkbox"/>
2	JARRETT MARTHA L	720 ECHO ST	CELINA	OH	45822	02/22/2005	0	QCE : X : 0	<input type="checkbox"/>	<input type="checkbox"/>
3	JARRETT WM A & MARTHA L	720 ECHO ST	CELINA	OH	45822		0	: 0	<input type="checkbox"/>	<input type="checkbox"/>

X: TTO LISTER: DF DATE: 04/14/2005 TIME: 12:00:00 AM LETTER LETTER REC'D GIS CODE

STREET/ROAD	TOPOGRAPHY	PU-UTILITIES-PR	NEIGHBORHOOD	INFLUENCE FACTORS	PROPERTY LOCATION	
<input checked="" type="checkbox"/> PAVED <input type="checkbox"/> GRAVEL <input type="checkbox"/> DIRT <input checked="" type="checkbox"/> SIDEWALKS <input type="checkbox"/> CURBS	<input checked="" type="checkbox"/> LEVEL <input type="checkbox"/> HIGH <input type="checkbox"/> LOW <input type="checkbox"/> ROLLING <input type="checkbox"/> STANDARD	<input type="checkbox"/> WATER <input type="checkbox"/> SEWER <input type="checkbox"/> GAS <input type="checkbox"/> ELECTRIC <input checked="" type="checkbox"/> STANDARD	<input type="checkbox"/> IMPROVING <input checked="" type="checkbox"/> STATIC <input type="checkbox"/> DECLINING <input type="checkbox"/> OLD <input type="checkbox"/> STANDARD	<input type="checkbox"/> A. NO ROAD <input type="checkbox"/> B. TOPGRHY <input type="checkbox"/> C. Ex Front <input type="checkbox"/> D. QUANTITY <input type="checkbox"/> E. SZ/SHAPE	<input type="checkbox"/> F. RESTRICT <input type="checkbox"/> G. WOOD LT <input type="checkbox"/> H. VACANCY <input type="checkbox"/> I. WATER FRONT <input type="checkbox"/> J. OTHER/CDU	720 ECHO ST, CELINA COMMENT TY2022:Net Gen=\$869.34, Other Assessment=\$0.00

LAND COMPUTATIONS

LAND TYPE	SIZE	M	RATE	C	INF	M	VALUE	C
F:Front	F41 D132	ST325	DP94	ADJ306			12,500	0
					TOTAL		12,500	0

VALUATION SUMMARY

VALUE YEAR	2023	2020	2017
REASON FOR CHANGE	RAPP	RAPP	RAPP
APPRAISED VALUE	LAND 12,500	8,800	7,300
	IMPR 79,600	71,200	53,700
	TOTAL 92,100	80,000	61,000
ASSESSED VALUE	LAND 4,380	3,080	2,560
	IMPR 27,860	24,920	18,800
	TOTAL 32,240	28,000	21,360

OCCUPANCY	EXTERIOR	FLOOR	AREA	CONST	VALUE
<input checked="" type="checkbox"/> SF <input type="checkbox"/> DU <input type="checkbox"/> TR	<input checked="" type="checkbox"/> WOOD	1	728	FR	126,160
<input type="checkbox"/> CONVERSION	<input type="checkbox"/> STUCCO	.5	364	FR	39,110
BUILDING TYPE	<input type="checkbox"/> ALM/VYNL				
<input type="checkbox"/> MOBILE HOME	<input type="checkbox"/> CONC BLK				
<input type="checkbox"/> BI/TR LEVEL	<input type="checkbox"/> METAL				
<input type="checkbox"/> MOD/MAN	<input type="checkbox"/> BRICK				
<input type="checkbox"/> _____	<input type="checkbox"/> STONE				
ROOFING	ROOF TYPE				
<input type="checkbox"/> METAL	<input checked="" type="checkbox"/> GABLE				
<input type="checkbox"/> SLT/TLE	<input type="checkbox"/> HIP				
<input checked="" type="checkbox"/> SHINGLES	<input type="checkbox"/> GAMBREL				
<input type="checkbox"/> SHAKES	<input type="checkbox"/> MANSARD				
<input type="checkbox"/> COMPOSITE	<input type="checkbox"/> FLAT				
FLOORS	B 1 2 3 U	SUBTOTAL			165,270
CONCRETE	<input type="checkbox"/> <input type="checkbox"/> <input type="checkbox"/> <input type="checkbox"/> <input type="checkbox"/>	MULTI-FAMILY #	0		0
WOOD	<input type="checkbox"/> <input checked="" type="checkbox"/> <input checked="" type="checkbox"/> <input type="checkbox"/> <input type="checkbox"/>	BUILDING TYPE	100%		0
TILE/COMPO	<input type="checkbox"/> <input type="checkbox"/> <input type="checkbox"/> <input type="checkbox"/> <input type="checkbox"/>	BSMT FINISH	0 S.F.		0
CARPET	<input type="checkbox"/> <input type="checkbox"/> <input type="checkbox"/> <input type="checkbox"/> <input type="checkbox"/>	FIREPLACE #	0		0
INT. FINISH	B 1 2 3 U	HEATING	0 S.F.		0
PLASTER/DW	<input type="checkbox"/> <input checked="" type="checkbox"/> <input checked="" type="checkbox"/> <input type="checkbox"/> <input type="checkbox"/>	AIR COND	0 S.F.		0
PANELING	<input type="checkbox"/> <input type="checkbox"/> <input type="checkbox"/> <input type="checkbox"/> <input type="checkbox"/>	PLUMBING #	0		0
UNFINISHED	<input type="checkbox"/> <input type="checkbox"/> <input type="checkbox"/> <input type="checkbox"/> <input type="checkbox"/>	GARAGES & CARPORTS			0
ACCOMMODATIONS		EXTRA FEATURES			9,900
# OF ROOMS		4	2		
BEDROOMS		2	2		
FIREPLACES					
HEAT & AC	B 1 2 3 U	SUBTOTAL			175,170
NO HEAT	<input type="checkbox"/> <input type="checkbox"/> <input type="checkbox"/> <input type="checkbox"/> <input type="checkbox"/>	GRADE FACTOR			95 %
CTRL HEAT	<input type="checkbox"/> <input checked="" type="checkbox"/> <input checked="" type="checkbox"/> <input type="checkbox"/> <input type="checkbox"/>	UNADJUSTED VALUE			166,410
HW/STEAM	<input type="checkbox"/> <input type="checkbox"/> <input type="checkbox"/> <input type="checkbox"/> <input type="checkbox"/>	FACTOR			100 %
ELECTRIC	<input type="checkbox"/> <input type="checkbox"/> <input type="checkbox"/> <input type="checkbox"/> <input type="checkbox"/>	OCCUPANCY		ST.HT	SIZE
HEAT PUMP	<input type="checkbox"/> <input type="checkbox"/> <input type="checkbox"/> <input type="checkbox"/> <input type="checkbox"/>	DWELLING	1.5	SK	1,092
FLR/WALL	<input type="checkbox"/> <input type="checkbox"/> <input type="checkbox"/> <input type="checkbox"/> <input type="checkbox"/>	1 Shed	PP	8x8	64
STVE/SPCE	<input type="checkbox"/> <input type="checkbox"/> <input type="checkbox"/> <input type="checkbox"/> <input type="checkbox"/>	2			
GEO THERMAL	<input type="checkbox"/> <input type="checkbox"/> <input type="checkbox"/> <input type="checkbox"/> <input type="checkbox"/>	3			
OUTSIDE	<input type="checkbox"/> <input type="checkbox"/> <input type="checkbox"/> <input type="checkbox"/> <input type="checkbox"/>	4			
CTRL A/C	<input type="checkbox"/> <input type="checkbox"/> <input type="checkbox"/> <input type="checkbox"/> <input type="checkbox"/>	5			
PLUMBING		6			
X FULL BATH		7			
X HALF BATH		8			
X FIXTURES		9			
		10			
		11			

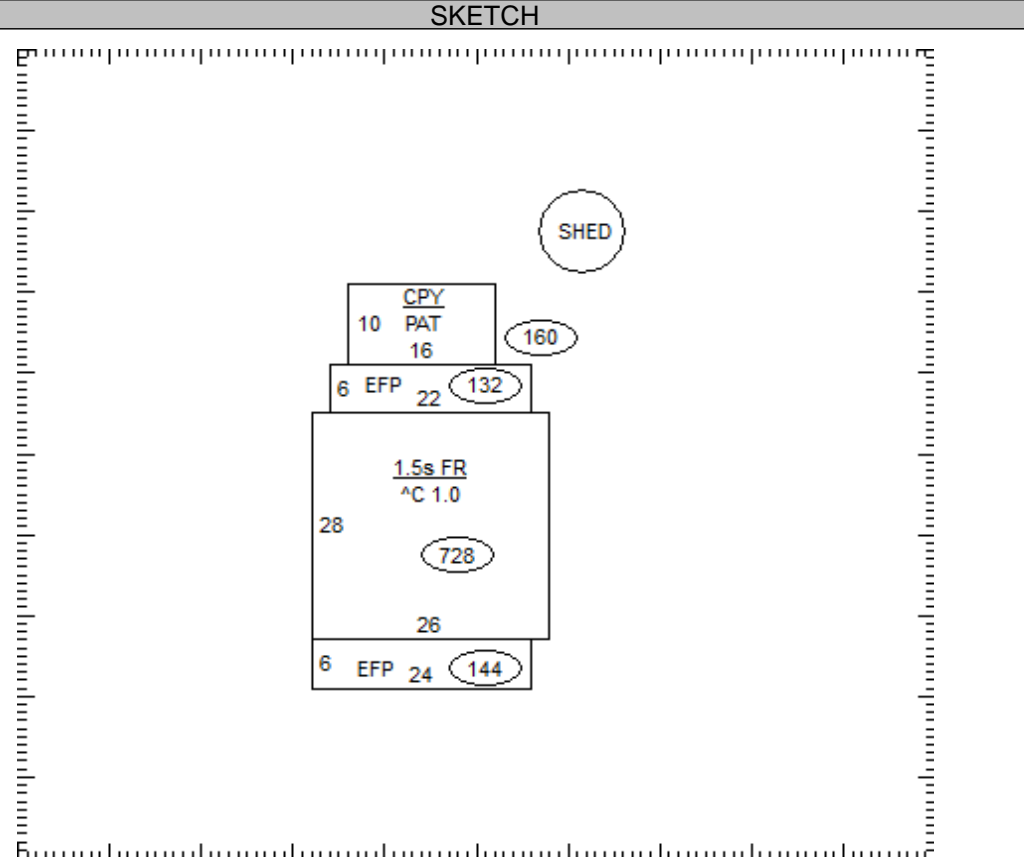

27-211300.0000

TOTAL 79,600

COMMENTS

Dwelling has an Economic Factor of 87%