

27-181800.0000

**MCNEIL SHANNON**

MCNEIL SHANNON

1102 GRAND AVE

CELINA, OH 45822

**LEGAL INFORMATION**

SUNNY MEADE ADD

LOT#: 10

OWNERSHIP	ADDRESS	CITY	STATE	ZIP	DATE	AMOUNT	DEED:CONV#	JS	VALID
1 MCNEIL SHANNON	1102 GRAND AVE	CELINA	OH	45822	01/30/2020	130,000	WDC : 56	<input type="checkbox"/>	<input checked="" type="checkbox"/>
2 OSTERHOLT LEO J JR	1102 GRAND AVE	CELINA	OH	45822	12/22/2009	90,000	WDC : A : 752	<input type="checkbox"/>	<input checked="" type="checkbox"/>
3 MCNEILAN LISA M	1102 GRAND AVE	CELINA	OH	45822	10/10/1997	0	: X : 0	<input type="checkbox"/>	<input type="checkbox"/>

X:  TTO LISTER: DF DATE: 04/10/2005 TIME: 12:00:00 AM  LETTER  LETTER REC'D GIS CODE

STREET/ROAD	TOPOGRAPHY	PU-UTILITIES-PR	NEIGHBORHOOD	INFLUENCE FACTORS	PROPERTY LOCATION	
<input checked="" type="checkbox"/> PAVED <input type="checkbox"/> GRAVEL <input type="checkbox"/> DIRT <input checked="" type="checkbox"/> SIDEWALKS <input type="checkbox"/> CURBS	<input checked="" type="checkbox"/> LEVEL <input type="checkbox"/> HIGH <input type="checkbox"/> LOW <input type="checkbox"/> ROLLING <input type="checkbox"/> STANDARD	<input type="checkbox"/> WATER <input type="checkbox"/> SEWER <input type="checkbox"/> GAS <input type="checkbox"/> ELECTRIC <input checked="" type="checkbox"/> STANDARD	<input type="checkbox"/> IMPROVING <input checked="" type="checkbox"/> STATIC <input type="checkbox"/> DECLINING <input type="checkbox"/> OLD <input type="checkbox"/> STANDARD	<input type="checkbox"/> A. NO ROAD <input type="checkbox"/> B. TOPGRHY <input type="checkbox"/> C. Ex Front <input type="checkbox"/> D. QUANTITY <input type="checkbox"/> E. SZ/SHAPE	<input type="checkbox"/> F. RESTRICT <input type="checkbox"/> G. WOOD LT <input type="checkbox"/> H. VACANCY <input type="checkbox"/> I. WATER FRONT <input type="checkbox"/> J. OTHER/CDU	1102 GRAND AVE, CELINA COMMENT TY2022:Net Gen=\$1,979.72, Other Assessment=\$0.00

LAND COMPUTATIONS

LAND TYPE	SIZE	M	RATE	C	INF	M	VALUE	C
F:Front	F90 D88	ST325	DP76	ADJ247		22,200		0
						TOTAL	22,200	0

VALUATION SUMMARY

VALUE YEAR	2023	2020	2017				
REASON FOR CHANGE	RAPP	RAPP	RAPP				
APPRAISED	<u>LAND</u>	22,200	15,700	13,000			
VALUE	<u>IMPR</u>	129,600	106,800	82,500			
	<u>TOTAL</u>	151,800	122,500	95,500			
ASSESSED	<u>LAND</u>	7,770	5,500	4,550			
VALUE	<u>IMPR</u>	45,360	37,380	28,880			
	<u>TOTAL</u>	53,130	42,880	33,430			

<b>OCCUPANCY</b>		<b>EXTERIOR</b>	
<input checked="" type="checkbox"/> SF	<input type="checkbox"/> DU	<input type="checkbox"/> WOOD	<input type="checkbox"/> STUCCO
<input type="checkbox"/> TR	<input type="checkbox"/> CONVERSION	<input checked="" type="checkbox"/> ALM/VYNL	<input type="checkbox"/> CONC BLK
<b>BUILDING TYPE</b>		<input type="checkbox"/> METAL	<input type="checkbox"/> BRICK
<input type="checkbox"/> MOBILE HOME	<input type="checkbox"/> BI/TR LEVEL	<input type="checkbox"/> STONE	
<input type="checkbox"/> MOD/MAN	<input type="checkbox"/>		

<b>ROOFING</b>		<b>ROOF TYPE</b>	
<input type="checkbox"/> METAL	<input checked="" type="checkbox"/> GABLE	<input type="checkbox"/> HIP	<input type="checkbox"/> GAMBREL
<input type="checkbox"/> SLT/TLE	<input type="checkbox"/> SHINGLES	<input type="checkbox"/> MANSARD	<input type="checkbox"/> FLAT
<input type="checkbox"/> SHAKES	<input type="checkbox"/> COMPOSITE		

<b>FLOORS</b>		B	1	2	3	U
CONCRETE	<input checked="" type="checkbox"/>	<input type="checkbox"/>	<input type="checkbox"/>	<input type="checkbox"/>	<input type="checkbox"/>	<input type="checkbox"/>
WOOD	<input type="checkbox"/>	<input checked="" type="checkbox"/>	<input type="checkbox"/>	<input type="checkbox"/>	<input type="checkbox"/>	<input type="checkbox"/>
TILE/COMPO	<input type="checkbox"/>	<input type="checkbox"/>	<input type="checkbox"/>	<input type="checkbox"/>	<input type="checkbox"/>	<input type="checkbox"/>
CARPET	<input type="checkbox"/>	<input type="checkbox"/>	<input type="checkbox"/>	<input type="checkbox"/>	<input type="checkbox"/>	<input type="checkbox"/>

<b>INT. FINISH</b>		B	1	2	3	U
PLASTER/DW	<input type="checkbox"/>	<input checked="" type="checkbox"/>	<input type="checkbox"/>	<input type="checkbox"/>	<input type="checkbox"/>	<input type="checkbox"/>
PANELING	<input type="checkbox"/>	<input type="checkbox"/>	<input type="checkbox"/>	<input type="checkbox"/>	<input type="checkbox"/>	<input type="checkbox"/>
UNFINISHED	<input checked="" type="checkbox"/>	<input type="checkbox"/>	<input type="checkbox"/>	<input type="checkbox"/>	<input type="checkbox"/>	<input type="checkbox"/>

<b>ACCOMMODATIONS</b>						
# OF ROOMS		6				
BEDROOMS		2				
FIREPLACES						

<b>HEAT &amp; AC</b>		B	1	2	3	U
NO HEAT	<input type="checkbox"/>	<input type="checkbox"/>	<input type="checkbox"/>	<input type="checkbox"/>	<input type="checkbox"/>	<input type="checkbox"/>
CTRL HEAT	<input type="checkbox"/>	<input checked="" type="checkbox"/>	<input type="checkbox"/>	<input type="checkbox"/>	<input type="checkbox"/>	<input type="checkbox"/>
HW/STEAM	<input type="checkbox"/>	<input type="checkbox"/>	<input type="checkbox"/>	<input type="checkbox"/>	<input type="checkbox"/>	<input type="checkbox"/>
ELECTRIC	<input type="checkbox"/>	<input type="checkbox"/>	<input type="checkbox"/>	<input type="checkbox"/>	<input type="checkbox"/>	<input type="checkbox"/>
HEAT PUMP	<input type="checkbox"/>	<input type="checkbox"/>	<input type="checkbox"/>	<input type="checkbox"/>	<input type="checkbox"/>	<input type="checkbox"/>
FLR/WALL	<input type="checkbox"/>	<input type="checkbox"/>	<input type="checkbox"/>	<input type="checkbox"/>	<input type="checkbox"/>	<input type="checkbox"/>
STVE/SPCE	<input type="checkbox"/>	<input type="checkbox"/>	<input type="checkbox"/>	<input type="checkbox"/>	<input type="checkbox"/>	<input type="checkbox"/>
GEO THERMAL	<input type="checkbox"/>	<input type="checkbox"/>	<input type="checkbox"/>	<input type="checkbox"/>	<input type="checkbox"/>	<input type="checkbox"/>
OUTSIDE	<input type="checkbox"/>	<input type="checkbox"/>	<input type="checkbox"/>	<input type="checkbox"/>	<input type="checkbox"/>	<input type="checkbox"/>
CTRL A/C	<input type="checkbox"/>	<input checked="" type="checkbox"/>	<input type="checkbox"/>	<input type="checkbox"/>	<input type="checkbox"/>	<input type="checkbox"/>

<b>PLUMBING</b>		<b>BASE</b>		<input checked="" type="checkbox"/>
X FULL BATH				
X HALF BATH				
X FIXTURES				

FLOOR	AREA	CONST	VALUE
1	1380	FR	193,900
BSMT	1380		19,730
<b>SUBTOTAL</b>			213,630
MULTI-FAMILY #	0		0
BUILDING TYPE	100%		0
BSMT FINISH	0 S.F.		0
FIREPLACE #	0		0
HEATING	0 S.F.		0
AIR COND	1,380 S.F.		2,280
PLUMBING #	0		0
GARAGES & CARPORTS			9,700
EXTRA FEATURES			3,600
<b>SUBTOTAL</b>			229,210
GRADE FACTOR			100 %
<b>UNADJUSTED VALUE</b>			229,210
FACTOR			100 %

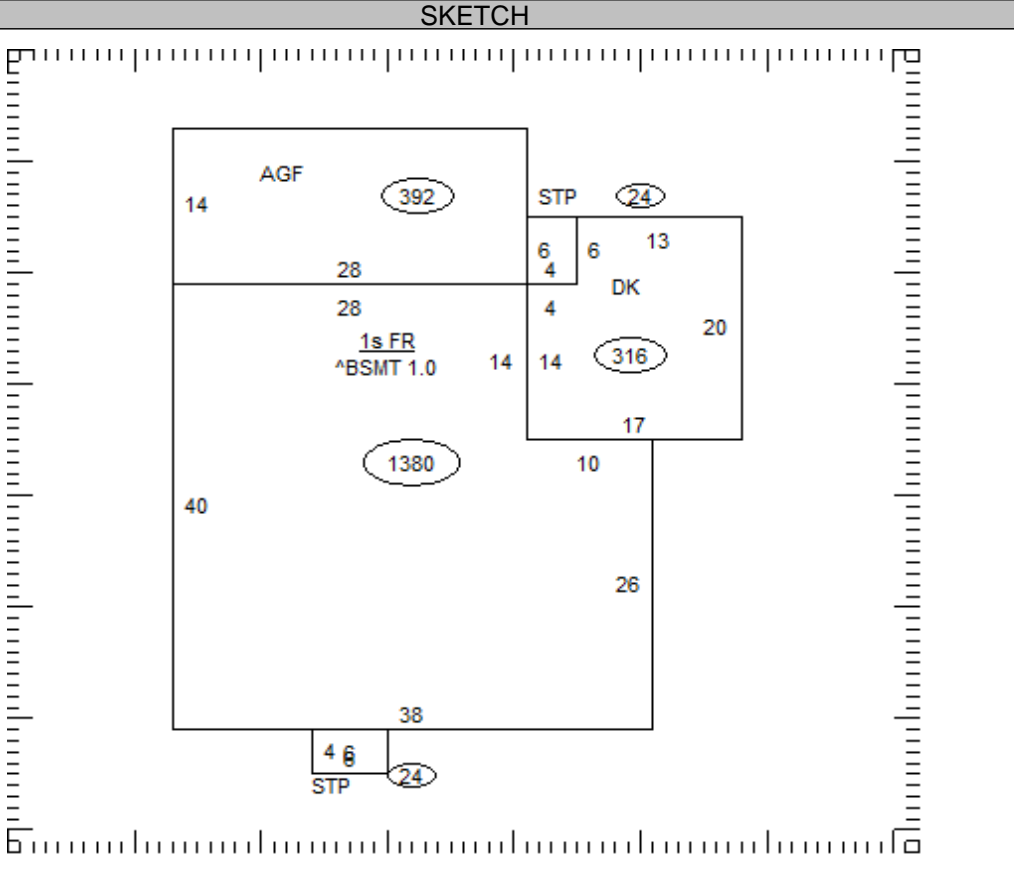

OCCUPANCY	ST.HT	SIZE	AREA	GRADE	PRICE	AGE	REMD	CND	UNADJ VAL	PHYS	PHYS VAL	FUNC	TRUE VAL
DWELLING	1	SK	1,380	C		1953	1970	G	229,210	35	148,990		129,600
1													
2													
3													
4													
5													
6													
7													
8													
9													
10													
11													

27-181800.0000

TOTAL 129,600

COMMENTS

Dwelling has an Economic Factor of 87%