

OCCUPANCY
 SF DU TR
 CONVERSION

BUILDING TYPE
 MOBILE HOME
 BI/TR LEVEL
 MOD/MAN

FLOOR	AREA	CONST	VALUE
1	1290	FR	187,670
.5	388	FR	34,950

ROOFING
 METAL
 SLT/TLE
 SHINGLES
 SHAKES
 COMPOSITE

ROOF TYPE
 GABLE
 HIP
 GAMBREL
 MANSARD
 FLAT

ROOFING	ROOF TYPE	BSMT	AREA	CONST	VALUE
		388			5,550
SUBTOTAL					228,170

FLOORS
 CONCRETE
 WOOD
 TILE/COMPO
 CARPET

INT. FINISH
 PLASTER/DW
 PANELING
 UNFINISHED

FLOORS	B	1	2	3	U	BSMT FINISH	FIREPLACE #	HEATING	AIR COND	PLUMBING #	GARAGES & CARPORTS	EXTRA FEATURES	SUBTOTAL
						0 S.F.	0	0 S.F.	1,678 S.F.	5	14,000	4,300	255,290

ACCOMMODATIONS
 # OF ROOMS: 1 4 2
 BEDROOMS: 1 1
 FIREPLACES: 1
 HEAT & AC: B 1 2 3 U

ACCOMMODATIONS	GRADE FACTOR	UNADJUSTED VALUE	FACTOR
	100 %	255,290	100 %

NO HEAT
 CTRL HEAT
 HW/STEAM
 ELECTRIC
 HEAT PUMP
 FLR/WALL
 STVE/SPCE
 GEOTHERMAL
 OUTSIDE
 CTRL A/C

OCCUPANCY	ST.HT	SIZE	AREA	GRADE	PRICE	AGE	REMD	CND	UNADJ VAL	PHYS	PHYS VAL	FUNC	TRUE VAL
DWELLING	1.5	SK	1,678	C		1947		A	255,290	45	140,410	ABT5	120,100
1 Shed		5x10	50	C		1980		A		77			0

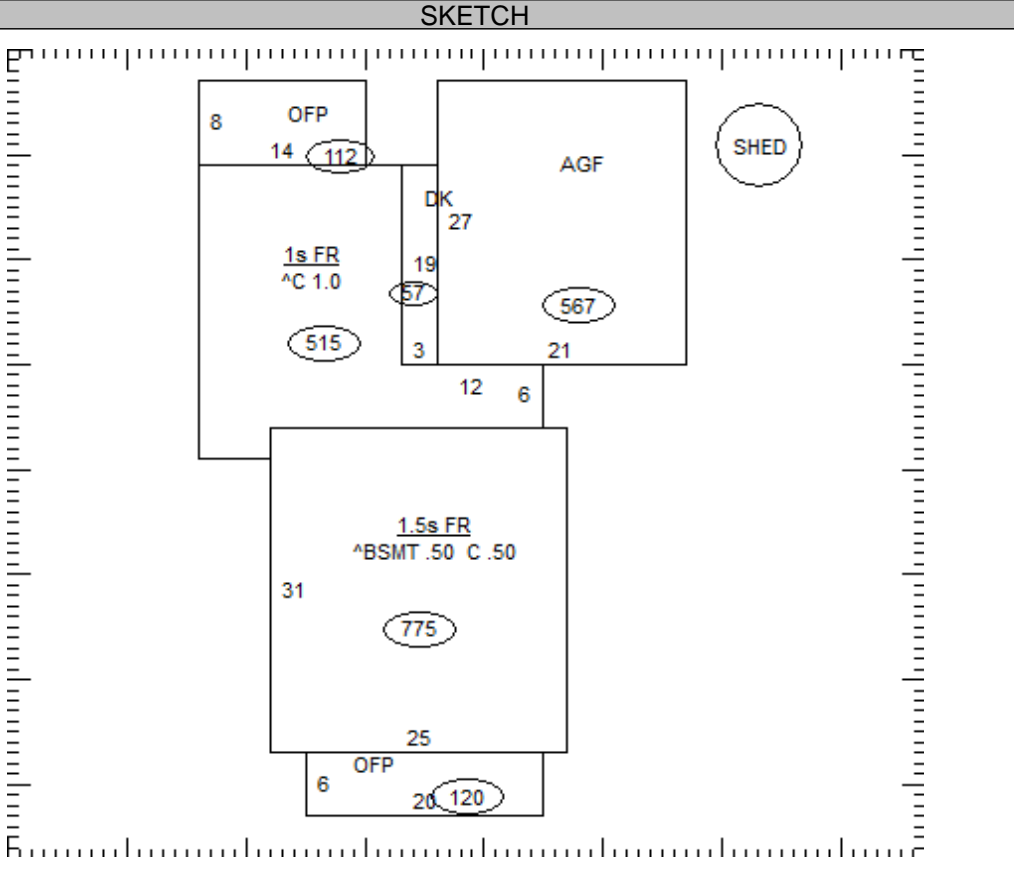

PLUMBING
 BASE

X FULL BATH: 1
 X HALF BATH: 1
 X FIXTURES

OCCUPANCY	ST.HT	SIZE	AREA	GRADE	PRICE	AGE	REMD	CND	UNADJ VAL	PHYS	PHYS VAL	FUNC	TRUE VAL
DWELLING	1.5	SK	1,678	C		1947		A	255,290	45	140,410	ABT5	120,100
1 Shed		5x10	50	C		1980		A		77			0
2													
3													
4													
5													
6													
7													
8													
9													
10													
11													

27-127100.0000 TOTAL 120,100

COMMENTS

Dwelling has an Economic Factor of 90%

OCCUPANCY
 SF DU TR
 CONVERSION

BUILDING TYPE
 MOBILE HOME
 BI/TR LEVEL
 MOD/MAN

EXTERIOR	FLOOR	AREA	CONST	VALUE
<input type="checkbox"/> WOOD				
<input type="checkbox"/> STUCCO				
<input type="checkbox"/> ALM/VYNL				
<input type="checkbox"/> CONC BLK				
<input type="checkbox"/> METAL				
<input type="checkbox"/> BRICK				
<input type="checkbox"/> STONE				

ROOFING
 METAL
 SLT/TLE
 SHINGLES
 SHAKES
 COMPOSITE

ROOF TYPE
 GABLE
 HIP
 GAMBREL
 MANSARD
 FLAT

FLOORS B 1 2 3 U

CONCRETE

WOOD

TILE/COMPO

CARPET

INT. FINISH B 1 2 3 U

PLASTER/DW

PANELING

UNFINISHED

ACCOMMODATIONS

OF ROOMS

BEDROOMS

FIREPLACES

HEAT & AC B 1 2 3 U

NO HEAT

CTRL HEAT

HW/STEAM

ELECTRIC

HEAT PUMP

FLR/WALL

STVE/SPCE

GEO THERMAL

OUTSIDE

CTRL A/C

PLUMBING BASE

X FULL BATH

X HALF BATH

X FIXTURES

SUBTOTAL		0
MULTI-FAMILY #	0	0
BUILDING TYPE	000%	0
BSMT FINISH	0 S.F.	0
FIREPLACE #	0	0
HEATING	0 S.F.	0
AIR COND	0 S.F.	0
PLUMBING #	0	0
GARAGES & CARPORTS		0
EXTRA FEATURES		0
SUBTOTAL		0
GRADE FACTOR		%
UNADJUSTED VALUE		0
FACTOR		%

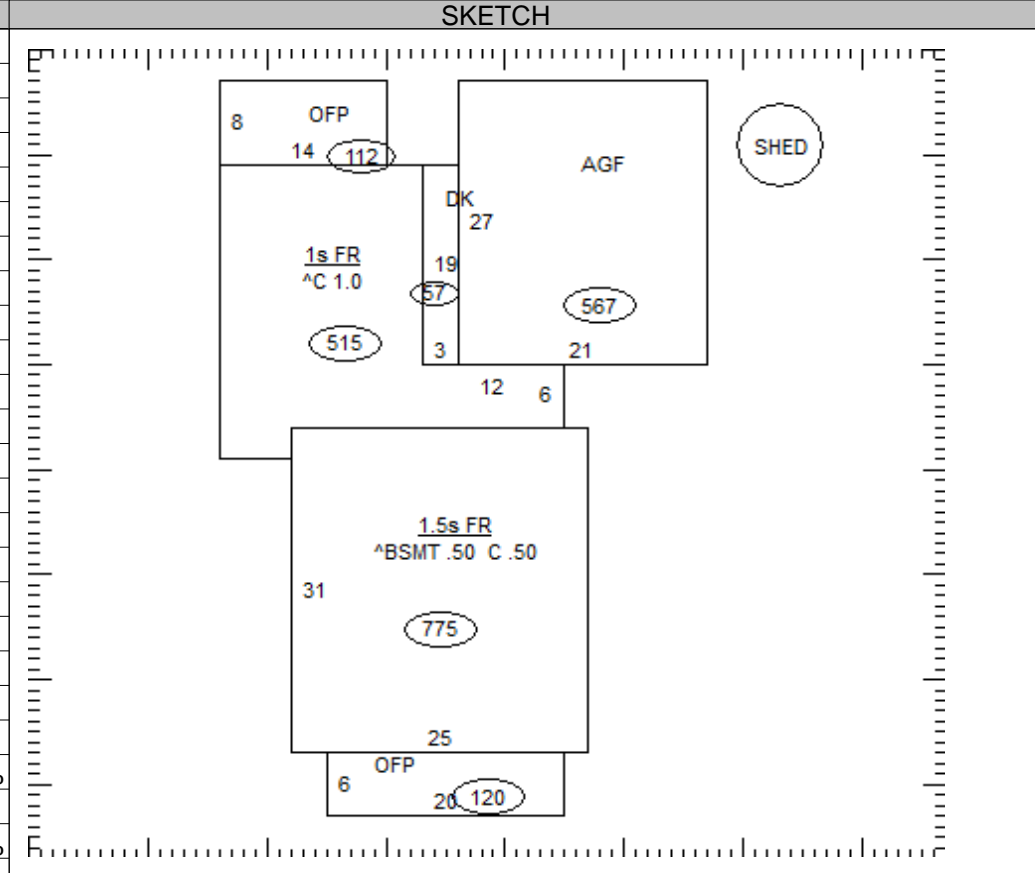

OCCUPANCY	ST.HT	SIZE	AREA	GRADE	PRICE	AGE	REMD	CND	UNADJ VAL	PHYS	PHYS VAL	FUNC	TRUE VAL
DWELLING		SK											
1													
2													
3													
4													
5													
6													
7													
8													
9													
10													
11													

27-127100.0000 TOTAL 0

COMMENTS