

Property Address: 128 W MARKET ST

DTE Code: 447



\*27-104000.0000\*

JEFFERSON TWP-CELINA CORP  
CELINA SD  
08-01-278-003

**LEGAL INFORMATION**

OLD PLAT  
LOT NO 294 W 1/2  
LOT#: 294  
**128 MARKET STREET LLC**  
128 MARKET STREET LLC  
128 W MARKET ST  
CELINA, OH 45822

Neighborhood CCBD50-50	
Map:	
Block:	
Card:	
Bk:	Pg:

COMMENT  
Tax Incentive Exempt Parcel: 27-104000.000K (TY2022 L=0; B=0; T=0)  
TY2022:Net Gen=\$6,260.34, Other Assessment=\$0.00  
2004 BASE VALUES:L:\$28910 B:\$713400 T:\$742310  
2020 DUPL VALUES:L:\$16,400 B:\$267,580 T:\$283,980  
2022 DUPL VALUES:L:\$49,200 B:\$282,870 T:\$332,070  
DE22 COMPLETE INT REMODEL; ADJ GRADE  
DE22 COMBINE PARCELS (27-105600, 27-105800)  
DE23 RESK, ADD OFFICES; DESKTOP RVW

Sales Data						Date
Date	Amount	Deed:Conv#	Use	Valid	Lister:	03/02/23
08/31/2020	299,900	3:WDC : 613	447	<input checked="" type="checkbox"/>	Pricer:	
10/25/2007	250,000	WDC : A-M : 759	444	<input type="checkbox"/>	Reviewer:	
12/05/1997	1,400,000	: A-M : 0	444	<input type="checkbox"/>	Final:	
				<input type="checkbox"/>	Call Back:	
				<input type="checkbox"/>	Visit:	

VALUATION SUMMARY				
VALUE YEAR	2023	2022	2022	2020
REASON FOR CHANGE	RAPP	MISC	NC	RAPP
ESTIMATED	LAND 80,930	49,200	16,400	16,400
MARKET VALUE	IMPR 197,690	282,870	282,870	267,580
	TOTAL 278,620	332,070	299,270	283,980
ASSESSED	LAND 28,330	17,220	5,740	5,740
VALUE	IMPR 69,190	99,000	99,000	93,650
	TOTAL 97,520	116,220	104,740	99,390

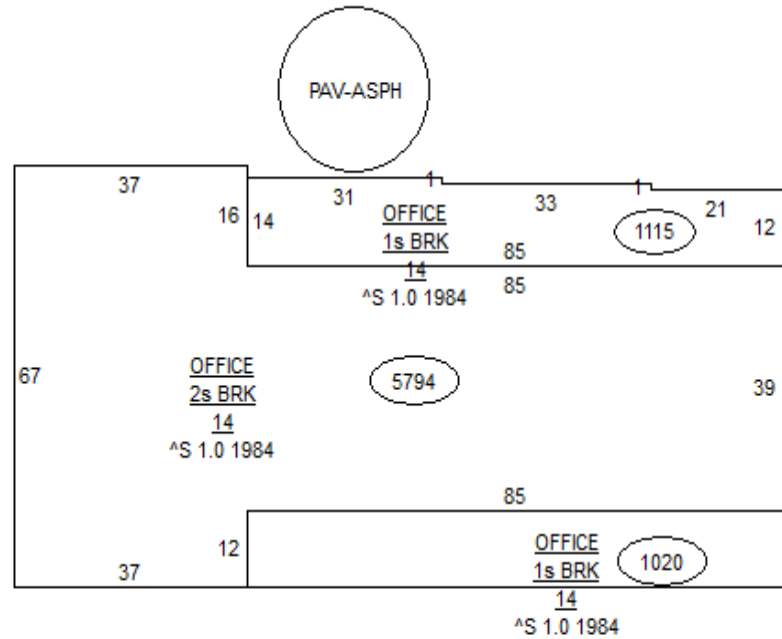

STREET/ROAD	TOPOGRAPHY	PU-UTILITIES-PR	ZONING
<input checked="" type="checkbox"/> PAVED	<input checked="" type="checkbox"/> LEVEL	<input type="checkbox"/> WATER	<input type="checkbox"/> AG-RES
<input type="checkbox"/> GRAVEL	<input type="checkbox"/> HIGH	<input type="checkbox"/> SEWER	<input checked="" type="checkbox"/> COMMERCIAL
<input type="checkbox"/> DIRT	<input type="checkbox"/> LOW	<input type="checkbox"/> GAS	<input type="checkbox"/> INDUSTRIAL
<input checked="" type="checkbox"/> SIDEWALKS	<input type="checkbox"/> ROLLING	<input type="checkbox"/> ELECTRIC	
<input checked="" type="checkbox"/> CURBS	<input type="checkbox"/> STANDARD	<input checked="" type="checkbox"/> STANDARD	

INFLUENCE FACTORS		
A. NO ROAD	E. SZ/SHAPE	I. WATER FRONT
B. TOPGRHY	F. RESTRICT	J. OTHER/CDU
C. Ex Front	G. WOOD LT	
D. QUANTITY	H. VACANCY	

LAND TYPE	SIZE	M	RATE	C	INF	M	VALUE	C
F:Front	F123 D132		ST700 DP94 ADJ658				80,930	0
Totals:							80,930	0

		EX WALL	A	ROOFING	A	WINDOW	A	DOORS	A	FOUNDATION	A	FRAMING	A	
CLASS/QUALITY RANK		STONE	<input type="checkbox"/>	GABLE/HIP	<input type="checkbox"/>	STORE FRT	<input type="checkbox"/>	OVERHEAD	<input type="checkbox"/>	SLAB	<input type="checkbox"/>	PRE ENG	<input type="checkbox"/>	
A) FP STRUCT. STEEL FRAME		1. BASIC	BRICK	<input type="checkbox"/>	SHED/FLAT	<input type="checkbox"/>	CASEMENT	<input type="checkbox"/>		CRAWL	<input type="checkbox"/>	STEEL	<input type="checkbox"/>	
B) R.C. FRAME		2. FAIR	CON BLK	<input type="checkbox"/>	CON DECK	<input type="checkbox"/>	DBLH	<input type="checkbox"/>		PILE/COL	<input type="checkbox"/>	REINF CONC	<input type="checkbox"/>	
C) MASONRY BEARING WALLS		3. AVE	WD/MTL	<input type="checkbox"/>	MTL DECK	<input type="checkbox"/>	SLIDE BY	<input type="checkbox"/>		REINFOR	<input type="checkbox"/>	CB/MASON	<input type="checkbox"/>	
D) WD OR STEEL FR EX. WALLS		4. GOOD	ENAM STL	<input type="checkbox"/>	WD DECK	<input type="checkbox"/>	CANOPY	A		STEEL	<input type="checkbox"/>	FRAME	<input type="checkbox"/>	
S) METAL M) MILL P) POLE		5. EXCEL	ALUM/VYL	<input type="checkbox"/>	METAL	<input type="checkbox"/>	LIGHTED	<input type="checkbox"/>	STEEL INS	<input type="checkbox"/>	BRICK	<input type="checkbox"/>	POLE	<input type="checkbox"/>
TOTAL AREA		PERIMETER	CON PANEL	<input type="checkbox"/>	ASPH	<input type="checkbox"/>	SOFFITS	<input type="checkbox"/>	WOOD	<input type="checkbox"/>	STONE	<input type="checkbox"/>	TILT UP	<input type="checkbox"/>
# STORIES		STORY HT	PLATE GLS	<input type="checkbox"/>	RUBBER	<input type="checkbox"/>	C S W	<input type="checkbox"/>	MTL	<input type="checkbox"/>	CON BLK	<input type="checkbox"/>	SANDWICH	<input type="checkbox"/>
AGE		SPRINKLER	STUCCO	<input type="checkbox"/>	BUILT UP	<input type="checkbox"/>	FACADE	A	GLASS	<input type="checkbox"/>	FRAME	<input type="checkbox"/>	STANDARD	<input type="checkbox"/>
			INSULATED	<input type="checkbox"/>	INSULATED	<input type="checkbox"/>			STANDARD	<input type="checkbox"/>	STANDARD	<input type="checkbox"/>		

H.V.A.C.		FLOORS	B	1	2	3	U	PARTITIONS	B	1	2	3	U	INTERIOR FINISH	B	1	2	3	U	
Electric	<input type="checkbox"/>	Electric Wall	<input type="checkbox"/>	CONCRETE				<input type="checkbox"/>	MASONRY	<input type="checkbox"/>	<input type="checkbox"/>	<input type="checkbox"/>	<input type="checkbox"/>	<input type="checkbox"/>	UNFINISHED	<input type="checkbox"/>	<input type="checkbox"/>	<input type="checkbox"/>	<input type="checkbox"/>	<input type="checkbox"/>
Forced Air Unit	<input type="checkbox"/>	Hot Water	<input type="checkbox"/>	WOOD				<input type="checkbox"/>	WD STUD	<input type="checkbox"/>	<input type="checkbox"/>	<input type="checkbox"/>	<input type="checkbox"/>	<input type="checkbox"/>	FINISH OPEN	<input type="checkbox"/>	<input type="checkbox"/>	<input type="checkbox"/>	<input type="checkbox"/>	<input type="checkbox"/>
Hot Water, Rad	<input type="checkbox"/>	Space/ Wall Furnace	<input type="checkbox"/>	TILE A Q V T				<input type="checkbox"/>	MTL STUD	<input type="checkbox"/>	<input type="checkbox"/>	<input type="checkbox"/>	<input type="checkbox"/>	<input type="checkbox"/>	FINISH DIV	<input type="checkbox"/>	<input type="checkbox"/>	<input type="checkbox"/>	<input type="checkbox"/>	<input type="checkbox"/>
Steam	<input type="checkbox"/>	Warm & Cld Air	<input type="checkbox"/>	CARPET				<input type="checkbox"/>	CEILINGS	B	1	2	3	U	PANEL	<input type="checkbox"/>	<input type="checkbox"/>	<input type="checkbox"/>	<input type="checkbox"/>	<input type="checkbox"/>
Ventilation	<input type="checkbox"/>	Heat Pump	<input type="checkbox"/>	ASPHALT				<input type="checkbox"/>	ACCUT/PANEL	<input type="checkbox"/>	<input type="checkbox"/>	<input type="checkbox"/>	<input type="checkbox"/>	<input type="checkbox"/>	PLASTER / DW	<input type="checkbox"/>	<input type="checkbox"/>	<input type="checkbox"/>	<input type="checkbox"/>	<input type="checkbox"/>
Package Unit	<input type="checkbox"/>	Ind TW Heat Pump	<input type="checkbox"/>	GRAVEL				<input type="checkbox"/>	PLASTER/DW	<input type="checkbox"/>	<input type="checkbox"/>	<input type="checkbox"/>	<input type="checkbox"/>	<input type="checkbox"/>	BLOCK	<input type="checkbox"/>	<input type="checkbox"/>	<input type="checkbox"/>	<input type="checkbox"/>	<input type="checkbox"/>
Hot & Cld Water	<input type="checkbox"/>	Evaporated Cool	<input type="checkbox"/>	DIRT				<input type="checkbox"/>	SUSP/OPEN	<input type="checkbox"/>	<input type="checkbox"/>	<input type="checkbox"/>	<input type="checkbox"/>	<input type="checkbox"/>	GLAZED TILE	<input type="checkbox"/>	<input type="checkbox"/>	<input type="checkbox"/>	<input type="checkbox"/>	<input type="checkbox"/>
Floor Furnace	<input type="checkbox"/>	Co-Ray-Vac	<input type="checkbox"/>	STANDARD				<input type="checkbox"/>	STANDARD	<input type="checkbox"/>				<input type="checkbox"/>	STANDARD	<input type="checkbox"/>				

Complete HVAC	<input type="checkbox"/>	No Heat	<input type="checkbox"/>	PLUMBING				A	LIGHTING				A				
Refrig. Cooling	<input type="checkbox"/>	Standard	<input type="checkbox"/>	NO PLUMBING				<input type="checkbox"/>	EXTRA FIXTURES				<input type="checkbox"/>	FLUORESCENT	<input type="checkbox"/>	METAL HALIDE	<input type="checkbox"/>
				2 FIXTURE BATH				<input type="checkbox"/>	STANDARD				<input type="checkbox"/>	SODIUM VAP	<input type="checkbox"/>	STANDARD	<input type="checkbox"/>
				3 FIXTURE BATH				<input type="checkbox"/>					<input type="checkbox"/>	MERCURY VAP	<input type="checkbox"/>		<input type="checkbox"/>

YARD ITEMS		CONST	HT	SIZE X SIZE	FL	AREA	UNITS	AGE	REM	CND	GRD	\$/UNIT	UNADJUSTED \$	PHY	FC	EC	MARKET VALUE
A	901.001:Paving: Asphalt				1	4,615		1984		A	N	.00	0	0	0	0	0

YARD ITEMS		CONST	HT	SIZE X SIZE	FL	AREA	UNITS	AGE	REM	CND	GRD	\$/UNIT	UNADJUSTED \$	PHY	FC	EC	MARKET VALUE
A	CBD.005: CBD-UPDIV		14		1	5,794		1984		A	A	27.00	156,440	30	0	0	109,510
1	CBD.002: CBD-FINDIV		14		1	1,115		1984		A	A	59.00	65,790	30	0	0	46,050
2	CBD.002: CBD-FINDIV		14	12 X 85	1	1,020		1984		A	A	59.00	60,180	30	0	0	42,130

AMENITY TOTAL																0	
																TOTAL IMPR	197,690

**COMMENTS**

PAVING, MEZZ, SPRINKLERS, VAULTS ARE INCLUDED IN THE PRICE OF BLDG.

Property Address: 128 W MARKET ST

DTE Code: 447



\*27-104000.0000\*

JEFFERSON TWP-CELINA CORP  
CELINA SD  
08-01-278-003

**LEGAL INFORMATION**

OLD PLAT  
LOT NO 294 W 1/2  
LOT#: 294  
**128 MARKET STREET LLC**  
128 MARKET STREET LLC  
128 W MARKET ST  
CELINA, OH 45822

Neighborhood CCBD50-50	
Map:	
Block:	
Card:	
Bk:	Pg:

COMMENT  
TAX INCENTIVE: TF505

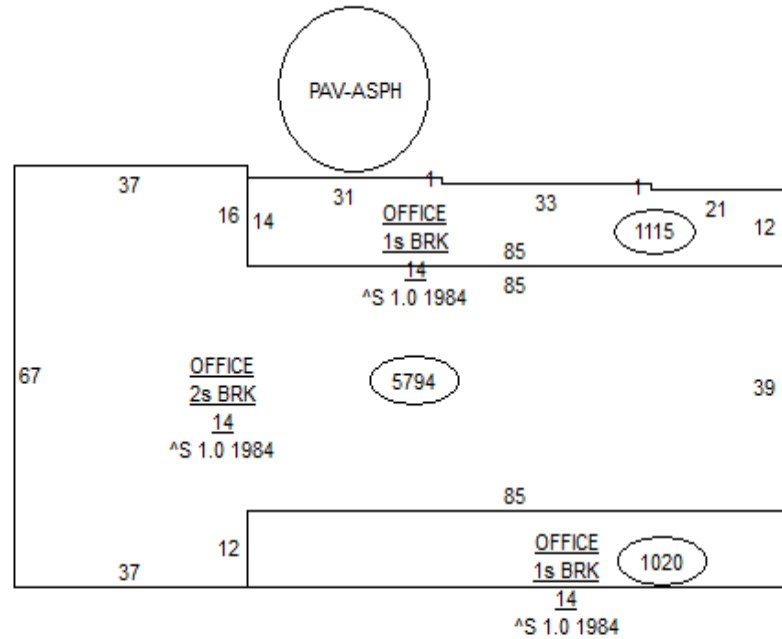

Sales Data						Date
Date	Amount	Deed:Conv#	Use	Valid	Lister:	03/02/23
08/31/2020	299,900	3:WDC : 613	447	<input checked="" type="checkbox"/>	Pricer:	
10/25/2007	250,000	WDC : A-M : 759	444	<input type="checkbox"/>	Reviewer:	
12/05/1997	1,400,000	: A-M : 0	444	<input type="checkbox"/>	Final:	
				<input type="checkbox"/>	Call Back:	
				<input type="checkbox"/>	Visit:	

VALUATION SUMMARY			
VALUE YEAR		2019	
REASON FOR CHANGE		MISC	
ESTIMATED MARKET VALUE	LAND	16,400	
	IMPR	282,870	
	TOTAL	299,270	
ASSESSED VALUE	LAND	5,740	
	IMPR	99,000	
	TOTAL	104,740	

STREET/ROAD	TOPOGRAPHY	PU-UTILITIES-PR	ZONING
<input checked="" type="checkbox"/> PAVED	<input checked="" type="checkbox"/> LEVEL	<input type="checkbox"/> WATER	<input type="checkbox"/> AG-RES
<input type="checkbox"/> GRAVEL	<input type="checkbox"/> HIGH	<input type="checkbox"/> SEWER	<input checked="" type="checkbox"/> COMMERCIAL
<input type="checkbox"/> DIRT	<input type="checkbox"/> LOW	<input type="checkbox"/> GAS	<input type="checkbox"/> INDUSTRIAL
<input checked="" type="checkbox"/> SIDEWALKS	<input type="checkbox"/> ROLLING	<input type="checkbox"/> ELECTRIC	
<input checked="" type="checkbox"/> CURBS	<input type="checkbox"/> STANDARD	<input checked="" type="checkbox"/> STANDARD	

INFLUENCE FACTORS		
A. NO ROAD	E. SZ/SHAPE	I. WATER FRONT
B. TOPGRHY	F. RESTRICT	J. OTHER/CDU
C. Ex Front	G. WOOD LT	
D. QUANTITY	H. VACANCY	

LAND TYPE	SIZE	M	RATE	C	INF	M	VALUE	C
Totals:						80,930	0	80,930

