



27-085100.0000

JEFFERSON TWP-CELINA CORP / CELINA SD

09-06-106-002

Property Class: 510

Neighborhood

27502720-01 -

Map: 05

Block: 02

Card: 36

Bk: Pg:

VAN GUNDY RENTALS LLC

VAN GUNDY RENTALS LLC

65 W WAYNE ST PO BOX 147

CHICKASAW, OH 45826

LEGAL INFORMATION

OLD PLAT

LOT NO 184 W 1/2

LOT#: 184

	OWNERSHIP	ADDRESS	CITY	STATE	ZIP	DATE	AMOUNT	DEED:CONV#	JS	VALID
1	VAN GUNDY RENTALS LLC C/O COLE & MOLLY VAN GUNDY	65 W WAYNE ST PO BOX	CHICKASAW	OH	45826	05/15/2023	65,000	WDC : 257	<input type="checkbox"/>	<input checked="" type="checkbox"/>
2	STEINBRUNNER RENTALS LLC	1149 JEFFERSON AVE	CELINA	OH	45822	12/10/2020	0	5:QCE : X : 0	<input type="checkbox"/>	<input type="checkbox"/>
3	STEINBRUNNER TODD R &	1149 JEFFERSON AVE	CELINA	OH	45822	11/01/2019	65,000	WDC : 752	<input type="checkbox"/>	<input type="checkbox"/>

X:	<input type="checkbox"/> TTO	LISTER: EE	DATE: 05/16/2005	TIME: 12:00:00 AM	<input type="checkbox"/> LETTER	<input type="checkbox"/> LETTER REC'D	GIS CODE
----	------------------------------	------------	------------------	-------------------	---------------------------------	---------------------------------------	----------

STREET/ROAD	TOPOGRAPHY	PU-UTILITIES-PR	NEIGHBORHOOD	INFLUENCE FACTORS	PROPERTY LOCATION
-------------	------------	-----------------	--------------	-------------------	-------------------

<input checked="" type="checkbox"/> PAVED	<input checked="" type="checkbox"/> LEVEL	<input type="checkbox"/> WATER	<input type="checkbox"/> IMPROVING	<input type="checkbox"/> A. NO ROAD	<input type="checkbox"/> F. RESTRICT	314 E ANTHONY ST, CELINA COMMENT TY2022:Net Gen=\$1,228.54, Other Assessment=\$0.00 DE16 DESKTOP RVW CHG: COR WDDK
<input type="checkbox"/> GRAVEL	<input type="checkbox"/> HIGH	<input type="checkbox"/> SEWER	<input checked="" type="checkbox"/> STATIC	<input type="checkbox"/> B. TOPGRHY	<input type="checkbox"/> G. WOOD LT	
<input type="checkbox"/> DIRT	<input type="checkbox"/> LOW	<input type="checkbox"/> GAS	<input type="checkbox"/> DECLINING	<input type="checkbox"/> C. Ex Front	<input type="checkbox"/> H. VACANCY	
<input checked="" type="checkbox"/> SIDEWALKS	<input type="checkbox"/> ROLLING	<input type="checkbox"/> ELECTRIC	<input type="checkbox"/> OLD	<input type="checkbox"/> D. QUANTITY	<input type="checkbox"/> I. WATER FRONT	
<input type="checkbox"/> CURBS	<input type="checkbox"/> STANDARD	<input checked="" type="checkbox"/> STANDARD	<input type="checkbox"/> STANDARD	<input type="checkbox"/> E. SZ/SHAPE	<input type="checkbox"/> J. OTHER/CDU	

LAND COMPUTATIONS

LAND TYPE	SIZE	M	RATE	C	INF	M	VALUE	C
F:Front	F41 D132	ST380	DP94	ADJ357		14,600	0	
					TOTAL	14,600	0	

VALUATION SUMMARY

VALUE YEAR	2023	2020	2017
REASON FOR CHANGE	RAPP	RAPP	RAPP
APPRAISED VALUE	LAND 14,600	9,100	7,300
	IMPR 87,400	66,900	49,300
	TOTAL 102,000	76,000	56,600
ASSESSED VALUE	LAND 5,110	3,190	2,560
	IMPR 30,590	23,420	17,260
	TOTAL 35,700	26,610	19,820

OCCUPANCY		EXTERIOR		FLOOR	AREA	CONST	VALUE	
<input checked="" type="checkbox"/> SF	<input type="checkbox"/> DU	<input type="checkbox"/> TR	<input checked="" type="checkbox"/> WOOD	1	868	FR	144,440	
<input type="checkbox"/> CONVERSION	<input type="checkbox"/> STUCCO	<input type="checkbox"/> ALM/VYNL	<input type="checkbox"/> STUCCO	2ND	392	FR	31,310	
BUILDING TYPE	<input type="checkbox"/> CONC BLK	<input type="checkbox"/> METAL	<input type="checkbox"/> BRICK	+	0	FR	3,350	
<input type="checkbox"/> MOBILE HOME	<input type="checkbox"/> METAL	<input type="checkbox"/> BRICK	<input type="checkbox"/> STONE					
<input type="checkbox"/> BI/TR LEVEL	<input type="checkbox"/> GABLE	<input type="checkbox"/> HIP	<input type="checkbox"/> GAMBREL					
<input type="checkbox"/> MOD/MAN	<input type="checkbox"/> SHINGLES	<input type="checkbox"/> MANSARD	<input type="checkbox"/> FLAT					
<input type="checkbox"/>	<input type="checkbox"/> COMPOSITE							
ROOFING		ROOF TYPE		SUBTOTAL				179,100
<input type="checkbox"/> METAL	<input checked="" type="checkbox"/> GABLE	<input type="checkbox"/> HIP	<input type="checkbox"/> GAMBREL	MULTI-FAMILY #	0		0	
<input type="checkbox"/> SLT/TLE	<input type="checkbox"/> SHINGLES	<input type="checkbox"/> MANSARD	<input type="checkbox"/> FLAT	BUILDING TYPE	100%		0	
<input checked="" type="checkbox"/> SHINGLES	<input type="checkbox"/> SHAKES			BSMT FINISH	0 S.F.		0	
<input type="checkbox"/> SHAKES	<input type="checkbox"/> COMPOSITE			FIREPLACE #	0		0	
<input type="checkbox"/>				HEATING	0 S.F.		0	
				AIR COND	0 S.F.		0	
				PLUMBING #	0		0	
				GARAGES & CARPORTS			0	
				EXTRA FEATURES			6,400	
				SUBTOTAL			185,500	
				GRADE FACTOR			95 %	
				UNADJUSTED VALUE			176,230	
				FACTOR			100 %	
FLOORS		B	1	2	3	U		
CONCRETE	<input type="checkbox"/>	<input type="checkbox"/>	<input type="checkbox"/>	<input type="checkbox"/>	<input type="checkbox"/>	<input type="checkbox"/>		
WOOD	<input type="checkbox"/>	<input type="checkbox"/>	<input type="checkbox"/>	<input type="checkbox"/>	<input type="checkbox"/>	<input type="checkbox"/>		
TILE/COMPO	<input type="checkbox"/>	<input checked="" type="checkbox"/>	<input type="checkbox"/>	<input type="checkbox"/>	<input type="checkbox"/>	<input type="checkbox"/>		
CARPET	<input type="checkbox"/>	<input type="checkbox"/>	<input checked="" type="checkbox"/>	<input type="checkbox"/>	<input type="checkbox"/>	<input type="checkbox"/>		
INT. FINISH		B	1	2	3	U		
PLASTER/DW	<input type="checkbox"/>	<input checked="" type="checkbox"/>	<input checked="" type="checkbox"/>	<input type="checkbox"/>	<input type="checkbox"/>	<input type="checkbox"/>		
PANELING	<input type="checkbox"/>	<input type="checkbox"/>	<input type="checkbox"/>	<input type="checkbox"/>	<input type="checkbox"/>	<input type="checkbox"/>		
UNFINISHED	<input type="checkbox"/>	<input type="checkbox"/>	<input type="checkbox"/>	<input type="checkbox"/>	<input type="checkbox"/>	<input type="checkbox"/>		
ACCOMMODATIONS								
# OF ROOMS		4	2					
BEDROOMS		1	2					
FIREPLACES								
HEAT & AC		B	1	2	3	U		
NO HEAT	<input type="checkbox"/>	<input type="checkbox"/>	<input type="checkbox"/>	<input type="checkbox"/>	<input type="checkbox"/>	<input type="checkbox"/>		
CTRL HEAT	<input type="checkbox"/>	<input checked="" type="checkbox"/>	<input checked="" type="checkbox"/>	<input checked="" type="checkbox"/>	<input type="checkbox"/>	<input type="checkbox"/>		
HW/STEAM	<input type="checkbox"/>	<input type="checkbox"/>	<input type="checkbox"/>	<input type="checkbox"/>	<input type="checkbox"/>	<input type="checkbox"/>		
ELECTRIC	<input type="checkbox"/>	<input type="checkbox"/>	<input type="checkbox"/>	<input type="checkbox"/>	<input type="checkbox"/>	<input type="checkbox"/>		
HEAT PUMP	<input type="checkbox"/>	<input type="checkbox"/>	<input type="checkbox"/>	<input type="checkbox"/>	<input type="checkbox"/>	<input type="checkbox"/>		
FLR/WALL	<input type="checkbox"/>	<input type="checkbox"/>	<input type="checkbox"/>	<input type="checkbox"/>	<input type="checkbox"/>	<input type="checkbox"/>		
STVE/SPCE	<input type="checkbox"/>	<input type="checkbox"/>	<input type="checkbox"/>	<input type="checkbox"/>	<input type="checkbox"/>	<input type="checkbox"/>		
GEO THERMAL	<input type="checkbox"/>	<input type="checkbox"/>	<input type="checkbox"/>	<input type="checkbox"/>	<input type="checkbox"/>	<input type="checkbox"/>		
OUTSIDE	<input type="checkbox"/>	<input type="checkbox"/>	<input type="checkbox"/>	<input type="checkbox"/>	<input type="checkbox"/>	<input type="checkbox"/>		
CTRL A/C	<input type="checkbox"/>	<input type="checkbox"/>	<input type="checkbox"/>	<input type="checkbox"/>	<input type="checkbox"/>	<input type="checkbox"/>		
PLUMBING							BASE <input checked="" type="checkbox"/>	
X FULL BATH								
X HALF BATH								
X FIXTURES								

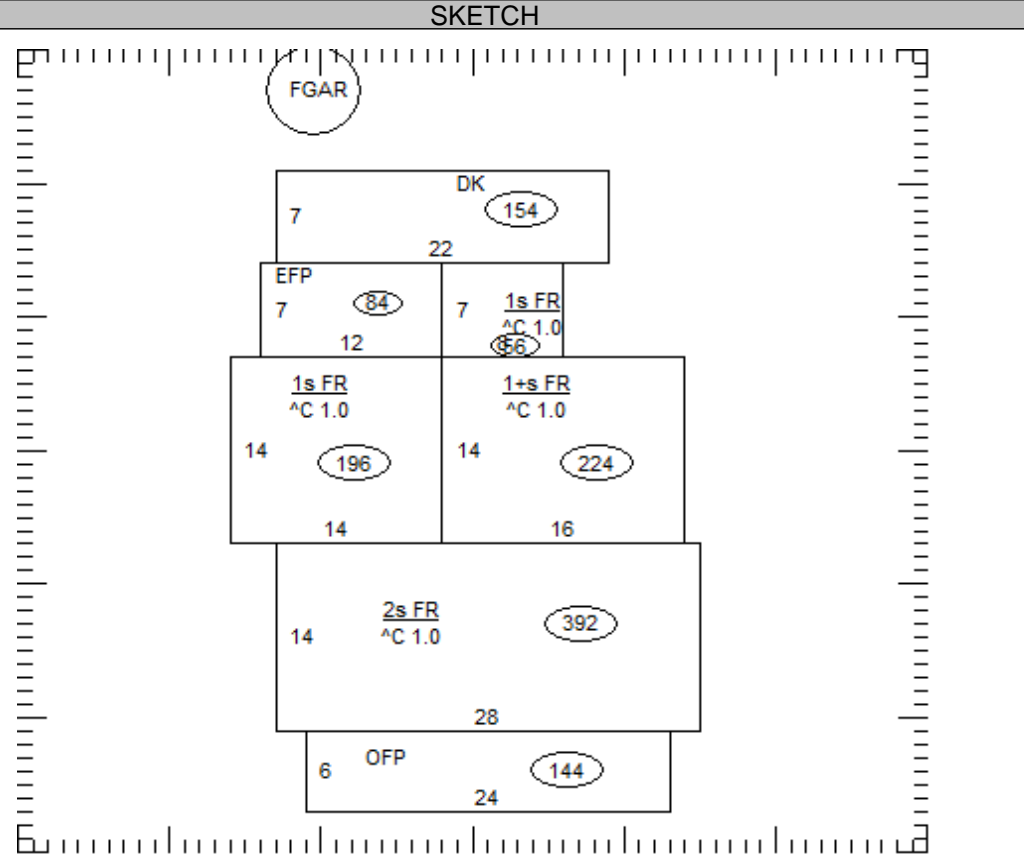

OCCUPANCY	ST.HT	SIZE	AREA	GRADE	PRICE	AGE	REMD	CND	UNADJ VAL	PHYS	PHYS VAL	FUNC	TRUE VAL
DWELLING	2	SK	1,260	C-		1898		A	176,230	45	96,930		87,200
1 Gar - Frame		11x18	198	D	18.96	1946		P	3,750	95	190		200
2													
3													
4													
5													
6													
7													
8													
9													
10													
11													

27-085100.0000

TOTAL 87,400

COMMENTS

Dwelling has an Economic Factor of 90%

Property Class: 510

Neighborhood
27502720-01 -

Map: 05
Block: 02
Card: 36

Bk: Pg:

JEFFERSON TWP-CELINA CORP / CELINA SD

09-06-106-002

27-085100.0000

VAN GUNDY RENTALS LLC
VAN GUNDY RENTALS LLC
65 W WAYNE ST PO BOX 147
CHICKASAW, OH 45826

LEGAL INFORMATION

OLD PLAT
LOT NO 184 W 1/2
LOT#: 184

	OWNERSHIP	ADDRESS	CITY	STATE	ZIP	DATE	AMOUNT	DEED:CONV#	JS	VALID
1	KEY SAMUEL S TRUSTEE	907 NOBLE RD	SAINT MARYS	OH	45885	11/28/2017	0	QCE : X : 0	<input type="checkbox"/>	<input type="checkbox"/>
2	KEY SAMUEL S TRUST	907 NOBLE RD	SAINT MARYS	OH	45885	08/04/1997	0	: X : 0	<input type="checkbox"/>	<input type="checkbox"/>
3							0	0	<input type="checkbox"/>	<input type="checkbox"/>

X: TTO LISTER: EE DATE: 05/16/2005 TIME: 12:00:00 AM LETTER LETTER REC'D GIS CODE

STREET/ROAD	TOPOGRAPHY	PU-UTILITIES-PR	NEIGHBORHOOD	INFLUENCE FACTORS	PROPERTY LOCATION	
<input checked="" type="checkbox"/> PAVED <input type="checkbox"/> GRAVEL <input type="checkbox"/> DIRT <input checked="" type="checkbox"/> SIDEWALKS <input type="checkbox"/> CURBS	<input checked="" type="checkbox"/> LEVEL <input type="checkbox"/> HIGH <input type="checkbox"/> LOW <input type="checkbox"/> ROLLING <input type="checkbox"/> STANDARD	<input type="checkbox"/> WATER <input type="checkbox"/> SEWER <input type="checkbox"/> GAS <input type="checkbox"/> ELECTRIC <input checked="" type="checkbox"/> STANDARD	<input type="checkbox"/> IMPROVING <input checked="" type="checkbox"/> STATIC <input type="checkbox"/> DECLINING <input type="checkbox"/> OLD <input type="checkbox"/> STANDARD	<input type="checkbox"/> A. NO ROAD <input type="checkbox"/> B. TOPGRHY <input type="checkbox"/> C. Ex Front <input type="checkbox"/> D. QUANTITY <input type="checkbox"/> E. SZ/SHAPE	<input type="checkbox"/> F. RESTRICT <input type="checkbox"/> G. WOOD LT <input type="checkbox"/> H. VACANCY <input type="checkbox"/> I. WATER FRONT <input type="checkbox"/> J. OTHER/CDU	314 E ANTHONY ST, CELINA COMMENT

LAND COMPUTATIONS							
LAND TYPE	SIZE	M	RATE	C	INF	M	VALUE C
TOTAL						14,600	0

VALUATION SUMMARY

VALUE YEAR							
REASON FOR CHANGE							
APPRaised	LAND						
VALUE	IMPR						
	TOTAL						
ASSESSED	LAND						
VALUE	IMPR						
	TOTAL						

OCCUPANCY	EXTERIOR	FLOOR	AREA	CONST	VALUE
<input type="checkbox"/> SF <input type="checkbox"/> DU <input type="checkbox"/> TR	<input type="checkbox"/> WOOD				
<input type="checkbox"/> CONVERSION	<input type="checkbox"/> STUCCO				
BUILDING TYPE	<input type="checkbox"/> ALM/VYNL				
<input type="checkbox"/> MOBILE HOME	<input type="checkbox"/> CONC BLK				
<input type="checkbox"/> BI/TR LEVEL	<input type="checkbox"/> METAL				
<input type="checkbox"/> MOD/MAN	<input type="checkbox"/> BRICK				
<input type="checkbox"/>	<input type="checkbox"/> STONE				

ROOFING	ROOF TYPE
<input type="checkbox"/> METAL	<input type="checkbox"/> GABLE
<input type="checkbox"/> SLT/TLE	<input type="checkbox"/> HIP
<input type="checkbox"/> SHINGLES	<input type="checkbox"/> GAMBREL
<input type="checkbox"/> SHAKES	<input type="checkbox"/> MANSARD
<input type="checkbox"/> COMPOSITE	<input type="checkbox"/> FLAT

FLOORS	B	1	2	3	U
CONCRETE	<input type="checkbox"/>	<input type="checkbox"/>	<input type="checkbox"/>	<input type="checkbox"/>	<input type="checkbox"/>
WOOD	<input type="checkbox"/>	<input type="checkbox"/>	<input type="checkbox"/>	<input type="checkbox"/>	<input type="checkbox"/>
TILE/COMPO	<input type="checkbox"/>	<input type="checkbox"/>	<input type="checkbox"/>	<input type="checkbox"/>	<input type="checkbox"/>
CARPET	<input type="checkbox"/>	<input type="checkbox"/>	<input type="checkbox"/>	<input type="checkbox"/>	<input type="checkbox"/>
INT. FINISH	B	1	2	3	U
PLASTER/DW	<input type="checkbox"/>	<input type="checkbox"/>	<input type="checkbox"/>	<input type="checkbox"/>	<input type="checkbox"/>
PANELING	<input type="checkbox"/>	<input type="checkbox"/>	<input type="checkbox"/>	<input type="checkbox"/>	<input type="checkbox"/>
UNFINISHED	<input type="checkbox"/>	<input type="checkbox"/>	<input type="checkbox"/>	<input type="checkbox"/>	<input type="checkbox"/>
ACCOMMODATIONS					
# OF ROOMS					
BEDROOMS					
FIREPLACES					
HEAT & AC	B	1	2	3	U
NO HEAT	<input type="checkbox"/>	<input type="checkbox"/>	<input type="checkbox"/>	<input type="checkbox"/>	<input type="checkbox"/>
CTRL HEAT	<input type="checkbox"/>	<input type="checkbox"/>	<input type="checkbox"/>	<input type="checkbox"/>	<input type="checkbox"/>
HW/STEAM	<input type="checkbox"/>	<input type="checkbox"/>	<input type="checkbox"/>	<input type="checkbox"/>	<input type="checkbox"/>
ELECTRIC	<input type="checkbox"/>	<input type="checkbox"/>	<input type="checkbox"/>	<input type="checkbox"/>	<input type="checkbox"/>
HEAT PUMP	<input type="checkbox"/>	<input type="checkbox"/>	<input type="checkbox"/>	<input type="checkbox"/>	<input type="checkbox"/>
FLR/WALL	<input type="checkbox"/>	<input type="checkbox"/>	<input type="checkbox"/>	<input type="checkbox"/>	<input type="checkbox"/>
STVE/SPCE	<input type="checkbox"/>	<input type="checkbox"/>	<input type="checkbox"/>	<input type="checkbox"/>	<input type="checkbox"/>
GEO THERMAL	<input type="checkbox"/>	<input type="checkbox"/>	<input type="checkbox"/>	<input type="checkbox"/>	<input type="checkbox"/>
OUTSIDE	<input type="checkbox"/>	<input type="checkbox"/>	<input type="checkbox"/>	<input type="checkbox"/>	<input type="checkbox"/>
CTRL A/C	<input type="checkbox"/>	<input type="checkbox"/>	<input type="checkbox"/>	<input type="checkbox"/>	<input type="checkbox"/>
PLUMBING	BASE <input type="checkbox"/>				
X FULL BATH					
X HALF BATH					
X FIXTURES					

SUBTOTAL		0
MULTI-FAMILY #	0	0
BUILDING TYPE	000%	0
BSMT FINISH	0 S.F.	0
FIREPLACE #	0	0
HEATING	0 S.F.	0
AIR COND	0 S.F.	0
PLUMBING #	0	0
GARAGES & CARPORTS		0
EXTRA FEATURES		0
SUBTOTAL		0
GRADE FACTOR		%
UNADJUSTED VALUE		0
FACTOR		%

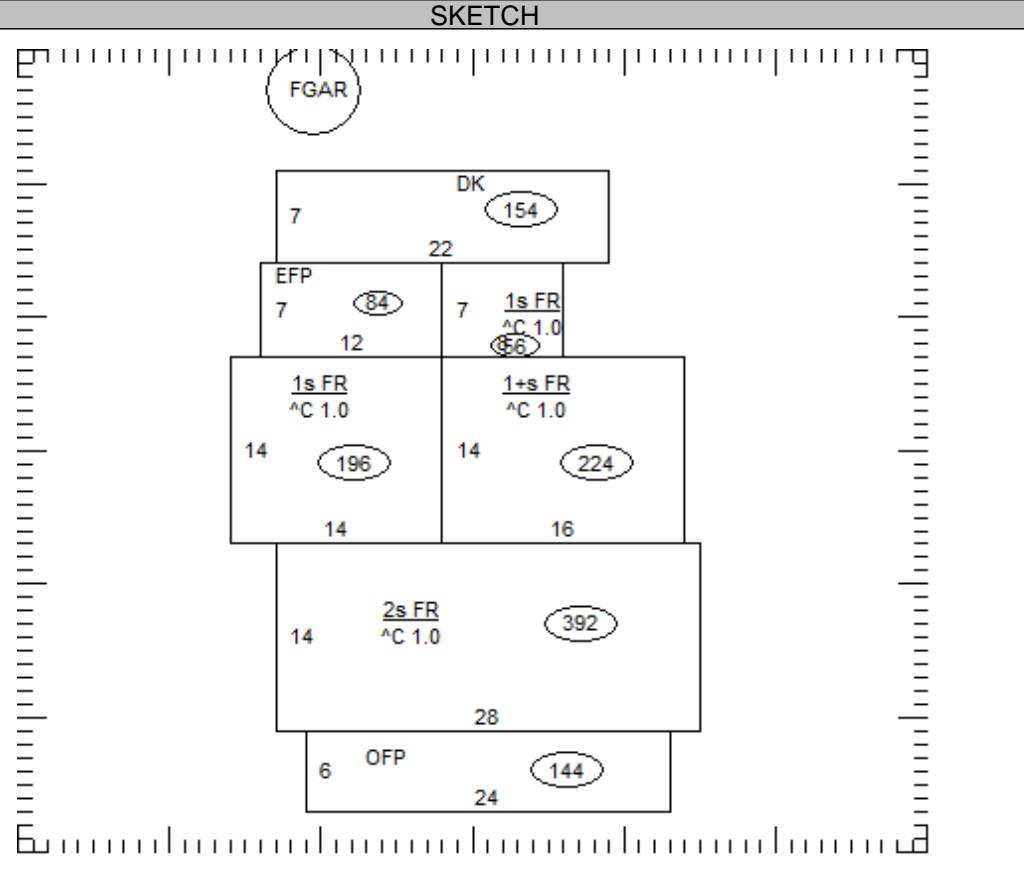

OCCUPANCY	ST.HT	SIZE	AREA	GRADE	PRICE	AGE	REMD	CND	UNADJ VAL	PHYS	PHYS VAL	FUNC	TRUE VAL
DWELLING		SK											
1													
2													
3													
4													
5													
6													
7													
8													
9													
10													
11													

27-085100.0000

TOTAL 0

COMMENTS