

27-080900.0000

LEFELD JASON A

LEFELD JASON A
330 E FAYETTE ST
CELINA, OH 45822

LEGAL INFORMATION

OLD PLAT
LOT NO 156 PT
LOT#: 156

	OWNERSHIP	ADDRESS	CITY	STATE	ZIP	DATE	AMOUNT	DEED:CONV#	JS	VALID
1	LEFELD JASON A	330 E FAYETTE ST	CELINA	OH	45822	11/10/2020	103,000	WDC : 844	<input type="checkbox"/>	<input checked="" type="checkbox"/>
2	DOWNEY MATTHEW D	330 E FAYETTE ST	CELINA	OH	45822	10/04/2013	67,900	WDC : 670	<input type="checkbox"/>	<input checked="" type="checkbox"/>
3	DONOVAN DENNIS R &	330 FAYETTE ST	CELINA	OH	45822	10/28/1996	36,000	: A : 0	<input type="checkbox"/>	<input checked="" type="checkbox"/>

X: TTO LISTER: DATE: 10/07/2011 TIME: 12:00:00 AM LETTER LETTER REC'D GIS CODE

STREET/ROAD	TOPOGRAPHY	PU-UTILITIES-PR	NEIGHBORHOOD	INFLUENCE FACTORS	PROPERTY LOCATION	
<input checked="" type="checkbox"/> PAVED <input type="checkbox"/> GRAVEL <input type="checkbox"/> DIRT <input checked="" type="checkbox"/> SIDEWALKS <input type="checkbox"/> CURBS	<input checked="" type="checkbox"/> LEVEL <input type="checkbox"/> HIGH <input type="checkbox"/> LOW <input type="checkbox"/> ROLLING <input type="checkbox"/> STANDARD	<input type="checkbox"/> WATER <input type="checkbox"/> SEWER <input type="checkbox"/> GAS <input type="checkbox"/> ELECTRIC <input checked="" type="checkbox"/> STANDARD	<input type="checkbox"/> IMPROVING <input checked="" type="checkbox"/> STATIC <input type="checkbox"/> DECLINING <input type="checkbox"/> OLD <input type="checkbox"/> STANDARD	<input type="checkbox"/> A. NO ROAD <input type="checkbox"/> B. TOPGRHY <input type="checkbox"/> C. Ex Front <input type="checkbox"/> D. QUANTITY <input type="checkbox"/> E. SZ/SHAPE	<input type="checkbox"/> F. RESTRICT <input type="checkbox"/> G. WOOD LT <input type="checkbox"/> H. VACANCY <input type="checkbox"/> I. WATER FRONT <input type="checkbox"/> J. OTHER/CDU	330 E FAYETTE ST, CELINA

COMMENT
Tax Incentive Exempt Parcel: 27-080900.000A (TY2022 L=0; B=0; T=0)27-080900.000K (TY2022 L=0; B=48,290; T=48,290)
TY2022:Net Gen=\$541.56, Other Assessment=\$780.26
2004 BASE VALUES:L:\$9310 B:\$24200 T:\$33510
2020 DUPL VALUES:L:\$12,200 B:\$69,600 T:\$81,800
2023 DUPL VALUES:L:\$19500 B:\$90800 T:\$110300
DE16 DESKTOP RVW CHG: ADD PAT
DE21 RMV OWN OCC; DIDN'T RET APP
TAX INCENTIVE: TF505

LAND COMPUTATIONS						
LAND TYPE	SIZE	M	RATE	C	INF	M VALUE C
F:Front	F62 D105	ST380	DP83	ADJ315		19,500 0
					TOTAL	9,310 0

VALUATION SUMMARY * Value Override Item

VALUE YEAR	* 2023	* 2020	* 2017				
REASON FOR CHANGE	RAPP	RAPP	RAPP				
APPRAISED VALUE	LAND 9,310	9,310	9,310				
	IMPR 24,200	24,200	24,200				
	TOTAL 33,510	33,510	33,510				
ASSESSED VALUE	LAND 3,260	3,260	3,260				
	IMPR 8,470	8,470	8,470				
	TOTAL 11,730	11,730	11,730				

OCCUPANCY		EXTERIOR		FLOOR	AREA	CONST	VALUE
<input checked="" type="checkbox"/> SF	<input type="checkbox"/> DU	<input type="checkbox"/> TR	<input type="checkbox"/> WOOD	1	957	FR	154,340
<input type="checkbox"/> CONVERSION			<input type="checkbox"/> STUCCO	.5	256	FR	25,600
BUILDING TYPE		<input checked="" type="checkbox"/> ALM/VYNL					
<input type="checkbox"/> MOBILE HOME			<input type="checkbox"/> CONC BLK				
<input type="checkbox"/> BI/TR LEVEL			<input type="checkbox"/> METAL				
<input type="checkbox"/> MOD/MAN			<input type="checkbox"/> BRICK				
<input type="checkbox"/>			<input type="checkbox"/> STONE				
ROOFING		ROOF TYPE					
<input type="checkbox"/> METAL			<input checked="" type="checkbox"/> GABLE				
<input type="checkbox"/> SLT/TLE			<input type="checkbox"/> HIP				
<input checked="" type="checkbox"/> SHINGLES			<input type="checkbox"/> GAMBREL				
<input type="checkbox"/> SHAKES			<input type="checkbox"/> MANSARD				
<input type="checkbox"/> COMPOSITE			<input type="checkbox"/> FLAT				

FLOORS		B	1	2	3	U	SUBTOTAL	VALUE	
CONCRETE	<input type="checkbox"/>	<input type="checkbox"/>	<input type="checkbox"/>	<input type="checkbox"/>	<input type="checkbox"/>	<input type="checkbox"/>	MULTI-FAMILY #	0	
WOOD	<input type="checkbox"/>	<input type="checkbox"/>	<input type="checkbox"/>	<input type="checkbox"/>	<input type="checkbox"/>	<input type="checkbox"/>	BUILDING TYPE	100%	
TILE/COMPO	<input type="checkbox"/>	<input checked="" type="checkbox"/>	<input type="checkbox"/>	<input type="checkbox"/>	<input type="checkbox"/>	<input type="checkbox"/>	BSMT FINISH	0 S.F.	
CARPET	<input type="checkbox"/>	<input checked="" type="checkbox"/>	<input checked="" type="checkbox"/>	<input type="checkbox"/>	<input type="checkbox"/>	<input type="checkbox"/>	FIREPLACE #	0	
INT. FINISH		B	1	2	3	U	HEATING	0 S.F.	
PLASTER/DW	<input type="checkbox"/>	<input checked="" type="checkbox"/>	<input checked="" type="checkbox"/>	<input type="checkbox"/>	<input type="checkbox"/>	<input type="checkbox"/>	AIR COND	1,213 S.F.	
PANELING	<input type="checkbox"/>	<input type="checkbox"/>	<input type="checkbox"/>	<input type="checkbox"/>	<input type="checkbox"/>	<input type="checkbox"/>	PLUMBING #	3	
UNFINISHED	<input type="checkbox"/>	<input type="checkbox"/>	<input type="checkbox"/>	<input type="checkbox"/>	<input type="checkbox"/>	<input type="checkbox"/>	GARAGES & CARPORTS	0	
ACCOMMODATIONS								EXTRA FEATURES	7,500
# OF ROOMS		5	2				SUBTOTAL	193,070	
BEDROOMS			2				GRADE FACTOR	95 %	
FIREPLACES							UNADJUSTED VALUE	183,420	
HEAT & AC	B	1	2	3	U			FACTOR	100 %

NO HEAT	<input type="checkbox"/>	<input type="checkbox"/>	<input type="checkbox"/>	<input type="checkbox"/>	<input type="checkbox"/>	<input type="checkbox"/>	OCCUPANCY	ST.HT	SIZE	AREA	GRADE	PRICE	AGE	REMD	CND	UNADJ VAL	PHYS	PHYS VAL	FUNC	TRUE VAL
CTRL HEAT	<input type="checkbox"/>	<input checked="" type="checkbox"/>	<input checked="" type="checkbox"/>	<input type="checkbox"/>	<input type="checkbox"/>	<input type="checkbox"/>	DWELLING	1.5	SK	1,213	C-		1941		A	183,420	45	100,880		90,800
HW/STEAM	<input type="checkbox"/>	<input type="checkbox"/>	<input type="checkbox"/>	<input type="checkbox"/>	<input type="checkbox"/>	<input type="checkbox"/>	1 Shed		8x10	80	C		1990		A		57			0
ELECTRIC	<input type="checkbox"/>	<input type="checkbox"/>	<input type="checkbox"/>	<input type="checkbox"/>	<input type="checkbox"/>	<input type="checkbox"/>	2													
HEAT PUMP	<input type="checkbox"/>	<input type="checkbox"/>	<input type="checkbox"/>	<input type="checkbox"/>	<input type="checkbox"/>	<input type="checkbox"/>	3													
FLR/WALL	<input type="checkbox"/>	<input type="checkbox"/>	<input type="checkbox"/>	<input type="checkbox"/>	<input type="checkbox"/>	<input type="checkbox"/>	4													
STVE/SPCE	<input type="checkbox"/>	<input type="checkbox"/>	<input type="checkbox"/>	<input type="checkbox"/>	<input type="checkbox"/>	<input type="checkbox"/>	5													
GEO THERMAL	<input type="checkbox"/>	<input type="checkbox"/>	<input type="checkbox"/>	<input type="checkbox"/>	<input type="checkbox"/>	<input type="checkbox"/>	6													
OUTSIDE	<input type="checkbox"/>	<input type="checkbox"/>	<input type="checkbox"/>	<input type="checkbox"/>	<input type="checkbox"/>	<input type="checkbox"/>	7													
CTRL A/C	<input type="checkbox"/>	<input checked="" type="checkbox"/>	<input checked="" type="checkbox"/>	<input type="checkbox"/>	<input type="checkbox"/>	<input type="checkbox"/>	8													
PLUMBING			BASE		<input checked="" type="checkbox"/>		9													
X FULL BATH		1					10													
X HALF BATH							11													
X FIXTURES																				

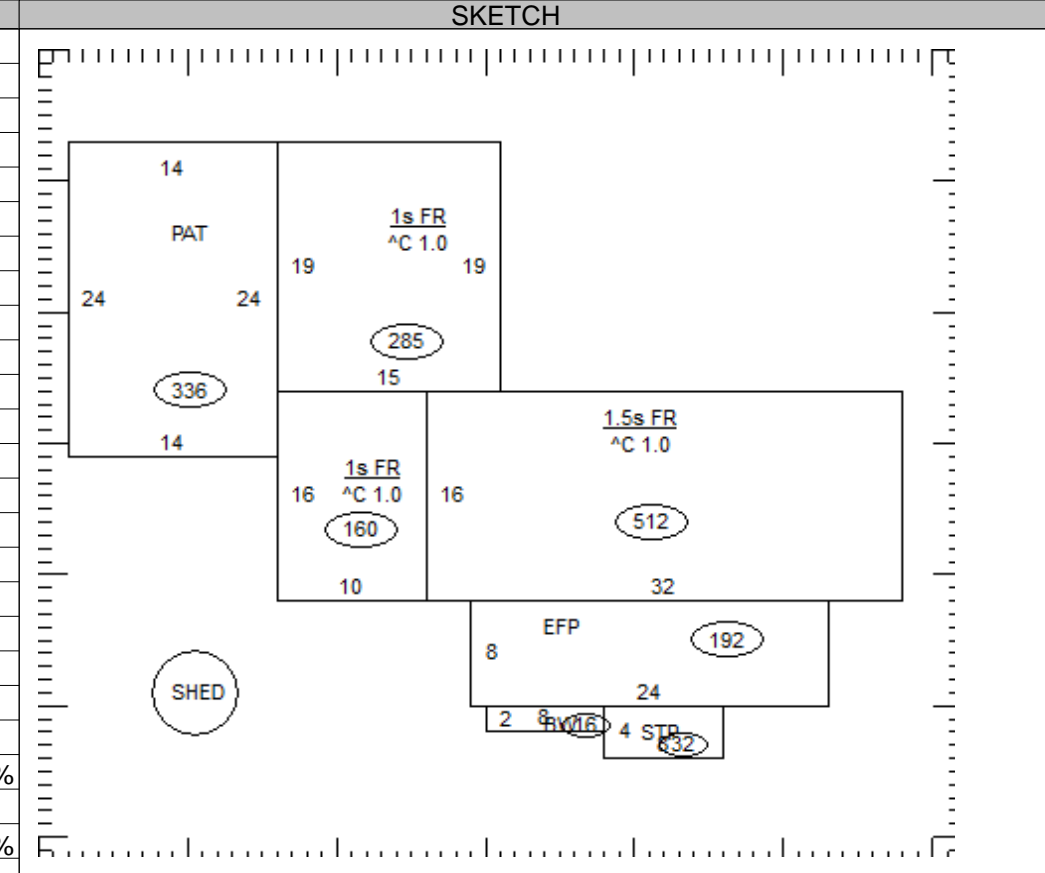

27-080900.0000																		TOTAL	*24,200
----------------	--	--	--	--	--	--	--	--	--	--	--	--	--	--	--	--	--	--------------	---------

COMMENTS

Dwelling has an Economic Factor of 90%