

Property Address: 230 W LOGAN ST

DTE Code: 401



27-065100.0000

JEFFERSON TWP-CELINA CORP
CELINA SD
08-01-429-001

LEGAL INFORMATION

OLD PLAT
LOT 61 PT N SD
LOT#: 61

MARCHAL CONSTRUCTION LLC
MARCHAL CONSTRUCTION LLC
5896 WABASH RD
COLDWATER, OH 45828

| |
|---------------------------|
| Neighborhood CSTR30-30 |
| Map: |
| Block: |
| Card: |
| Bk: Pg: |

COMMENT
Tax Incentive Exempt Parcel: 27-065100.000K (TY2022 L=0; B=29,380; T=29,380)
TY2022:Net Gen=\$2,306.56, Other Assessment=\$553.74
2004 BASE VALUES:L:\$12800 B:\$109540 T:\$122,340
2020 DUPL VALUES:L:\$11370 B:\$140,350 T:\$151,720
2023 DUPL VALUE: L:\$18,920 B:\$156480 T:\$175,400
DE17 TTO/COR DPLX TO TRI, COR 2ND DPLX TO SNGL FAM
DE17 DESKTOP RVW CHGS:ADJ PRICING/ALLOW 2ND DUPLEX TO VALUE
DE17 APPLY TIF

| Sales Data | | | | | | Date |
|------------|---------|------------|---------------|-------------------------------------|------------|----------|
| Date | Amount | Deed:Conv# | Use | Valid | Lister: | 03/29/23 |
| 12/23/2020 | 255,000 | | 2:WDC : 972 | <input checked="" type="checkbox"/> | Pricer: | |
| 02/19/2016 | 0 | | 2:QCE : X : 0 | <input type="checkbox"/> | Reviewer: | |
| 07/01/2015 | 168,000 | | 2:WDC : 427 | <input checked="" type="checkbox"/> | Final: | |
| 05/06/2014 | 175,000 | | 3:WDC : 246 | <input checked="" type="checkbox"/> | Call Back: | |
| 07/11/2007 | 0 | | QCE : X : 0 | <input type="checkbox"/> | Visit: | |

| VALUATION SUMMARY | | | | |
|-------------------|---------|---------|---------|---------|
| VALUE YEAR | * 2023 | * 2020 | * 2017 | 2017 |
| REASON FOR CHANGE | RAPP | RAPP | MISC | MISC |
| ESTIMATED | 12,800 | 12,800 | 12,800 | 11,370 |
| MARKET VALUE | 109,540 | 109,540 | 109,540 | 197,180 |
| | TOTAL | 122,340 | 122,340 | 208,550 |
| ASSESSED | 4,480 | 4,480 | 4,480 | 3,980 |
| VALUE | 38,340 | 38,340 | 38,340 | 69,010 |
| | TOTAL | 42,820 | 42,820 | 72,990 |

| LAND TYPE | SIZE | M | RATE | C | INF | M | VALUE | C |
|-----------|----------|---|-------------------|---|-----|---|--------|---|
| F:Front | F83 D126 | | ST250 DP91 ADJ228 | | | | 18,920 | 0 |
| Totals: | | | | | | | 12,800 | 0 |

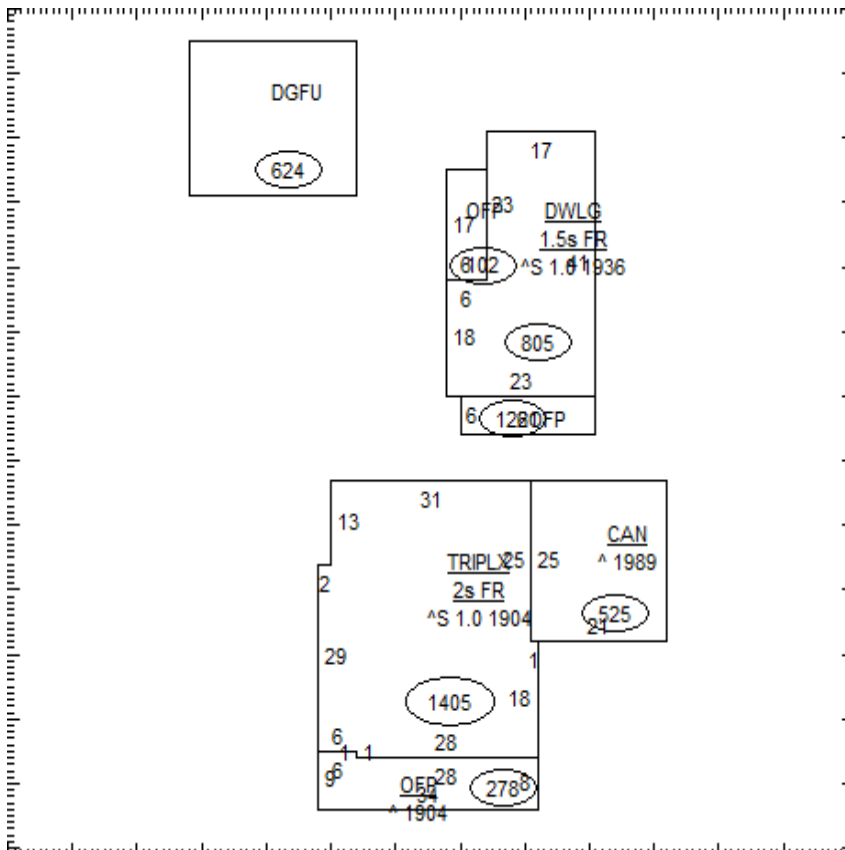

| STREET/ROAD | TOPOGRAPHY | PU-UTILITIES-PR | ZONING |
|---|---|--|--|
| <input checked="" type="checkbox"/> PAVED | <input checked="" type="checkbox"/> LEVEL | <input type="checkbox"/> WATER | <input type="checkbox"/> AG-RES |
| <input type="checkbox"/> GRAVEL | <input type="checkbox"/> HIGH | <input type="checkbox"/> SEWER | <input checked="" type="checkbox"/> COMMERCIAL |
| <input type="checkbox"/> DIRT | <input type="checkbox"/> LOW | <input type="checkbox"/> GAS | <input type="checkbox"/> INDUSTRIAL |
| <input checked="" type="checkbox"/> SIDEWALKS | <input type="checkbox"/> ROLLING | <input type="checkbox"/> ELECTRIC | |
| <input checked="" type="checkbox"/> CURBS | <input type="checkbox"/> STANDARD | <input checked="" type="checkbox"/> STANDARD | |

| INFLUENCE FACTORS | | |
|-------------------|-------------|----------------|
| A. NO ROAD | E. SZ/SHAPE | I. WATER FRONT |
| B. TOPGRHY | F. RESTRICT | J. OTHER/CDU |
| C. Ex Front | G. WOOD LT | |
| D. QUANTITY | H. VACANCY | |

| | | | | | | | | | | | | | | | |
|-----------------------------|--|-----------|--------------------------|--------------------------|--------------------------|--------------------------|--------------------------|--------------------------|--------------------------|--------------------------|--------------------------|--------------------------|--------------------------|--------------------------|--------------------------|
| | | EX WALL | A | ROOFING | A | WINDOW | A | DOORS | A | FOUNDATION | A | FRAMING | A | | |
| CLASS/QUALITY RANK | | STONE | <input type="checkbox"/> | GABLE/HIP | <input type="checkbox"/> | STORE FRT | <input type="checkbox"/> | OVERHEAD | <input type="checkbox"/> | SLAB | <input type="checkbox"/> | PRE ENG | <input type="checkbox"/> | | |
| A) FP STRUCT. STEEL FRAME | | 1. BASIC | BRICK | <input type="checkbox"/> | SHED/FLAT | <input type="checkbox"/> | CASEMENT | <input type="checkbox"/> | | CRAWL | <input type="checkbox"/> | STEEL | <input type="checkbox"/> | | |
| B) R.C. FRAME | | 2. FAIR | CON BLK | <input type="checkbox"/> | CON DECK | <input type="checkbox"/> | DBLH | <input type="checkbox"/> | | PILE/COL | <input type="checkbox"/> | REINF CONC | <input type="checkbox"/> | | |
| C) MASONRY BEARING WALLS | | 3. AVE | WD/MTL | <input type="checkbox"/> | MTL DECK | <input type="checkbox"/> | SLIDE BY | <input type="checkbox"/> | | REINFOR | <input type="checkbox"/> | CB/MASON | <input type="checkbox"/> | | |
| D) WD OR STEEL FR EX. WALLS | | 4. GOOD | ENAM STL | <input type="checkbox"/> | WD DECK | <input type="checkbox"/> | CANOPY | A | | STEEL | <input type="checkbox"/> | FRAME | <input type="checkbox"/> | | |
| S) METAL M) MILL P) POLE | | 5. EXCEL | ALUM/VYL | <input type="checkbox"/> | METAL | <input type="checkbox"/> | LIGHTED | <input type="checkbox"/> | STEEL INS | <input type="checkbox"/> | BRICK | <input type="checkbox"/> | POLE | <input type="checkbox"/> | |
| TOTAL AREA | | PERIMETER | 0 | CON PANEL | <input type="checkbox"/> | ASPH | <input type="checkbox"/> | SOFFITS | <input type="checkbox"/> | WOOD | <input type="checkbox"/> | STONE | <input type="checkbox"/> | TILT UP | <input type="checkbox"/> |
| # STORIES | | STORY HT | PLATE GLS | <input type="checkbox"/> | RUBBER | <input type="checkbox"/> | C S W | <input type="checkbox"/> | MTL | <input type="checkbox"/> | CON BLK | <input type="checkbox"/> | SANDWICH | <input type="checkbox"/> | |
| AGE | | SPRINKLER | STUCCO | <input type="checkbox"/> | BUILT UP | <input type="checkbox"/> | FACADE | A | GLASS | <input type="checkbox"/> | FRAME | <input type="checkbox"/> | STANDARD | <input type="checkbox"/> | |
| | | | INSULATED | <input type="checkbox"/> | INSULATED | <input type="checkbox"/> | | | STANDARD | <input type="checkbox"/> | STANDARD | <input type="checkbox"/> | | | |

| | | | | | | | | | | | | | | | | | | | | |
|-----------------|--------------------------|---------------------|--------------------------|--------------|---|---|---|--------------------------|-------------|--------------------------|--------------------------|--------------------------|--------------------------|--------------------------|--------------|--------------------------|--------------------------|--------------------------|--------------------------|--------------------------|
| H.V.A.C. | | FLOORS | B | 1 | 2 | 3 | U | PARTITIONS | B | 1 | 2 | 3 | U | INTERIOR FINISH | B | 1 | 2 | 3 | U | |
| Electric | <input type="checkbox"/> | Electric Wall | <input type="checkbox"/> | CONCRETE | | | | <input type="checkbox"/> | MASONRY | <input type="checkbox"/> | <input type="checkbox"/> | <input type="checkbox"/> | <input type="checkbox"/> | <input type="checkbox"/> | UNFINISHED | <input type="checkbox"/> | <input type="checkbox"/> | <input type="checkbox"/> | <input type="checkbox"/> | <input type="checkbox"/> |
| Forced Air Unit | <input type="checkbox"/> | Hot Water | <input type="checkbox"/> | WOOD | | | | <input type="checkbox"/> | WD STUD | <input type="checkbox"/> | <input type="checkbox"/> | <input type="checkbox"/> | <input type="checkbox"/> | <input type="checkbox"/> | FINISH OPEN | <input type="checkbox"/> | <input type="checkbox"/> | <input type="checkbox"/> | <input type="checkbox"/> | <input type="checkbox"/> |
| Hot Water, Rad | <input type="checkbox"/> | Space/ Wall Furnace | <input type="checkbox"/> | TILE A Q V T | | | | <input type="checkbox"/> | MTL STUD | <input type="checkbox"/> | <input type="checkbox"/> | <input type="checkbox"/> | <input type="checkbox"/> | <input type="checkbox"/> | FINISH DIV | <input type="checkbox"/> | <input type="checkbox"/> | <input type="checkbox"/> | <input type="checkbox"/> | <input type="checkbox"/> |
| Steam | <input type="checkbox"/> | Warm & Cld Air | <input type="checkbox"/> | CARPET | | | | <input type="checkbox"/> | CEILING | B | 1 | 2 | 3 | U | PANEL | <input type="checkbox"/> | <input type="checkbox"/> | <input type="checkbox"/> | <input type="checkbox"/> | <input type="checkbox"/> |
| Ventilation | <input type="checkbox"/> | Heat Pump | <input type="checkbox"/> | ASPHALT | | | | <input type="checkbox"/> | ACCUT/PANEL | <input type="checkbox"/> | <input type="checkbox"/> | <input type="checkbox"/> | <input type="checkbox"/> | <input type="checkbox"/> | PLASTER / DW | <input type="checkbox"/> | <input type="checkbox"/> | <input type="checkbox"/> | <input type="checkbox"/> | <input type="checkbox"/> |
| Package Unit | <input type="checkbox"/> | Ind TW Heat Pump | <input type="checkbox"/> | GRAVEL | | | | <input type="checkbox"/> | PLASTER/DW | <input type="checkbox"/> | <input type="checkbox"/> | <input type="checkbox"/> | <input type="checkbox"/> | <input type="checkbox"/> | BLOCK | <input type="checkbox"/> | <input type="checkbox"/> | <input type="checkbox"/> | <input type="checkbox"/> | <input type="checkbox"/> |
| Hot & Cld Water | <input type="checkbox"/> | Evaporated Cool | <input type="checkbox"/> | DIRT | | | | <input type="checkbox"/> | SUSP/OPEN | <input type="checkbox"/> | <input type="checkbox"/> | <input type="checkbox"/> | <input type="checkbox"/> | <input type="checkbox"/> | GLAZED TILE | <input type="checkbox"/> | <input type="checkbox"/> | <input type="checkbox"/> | <input type="checkbox"/> | <input type="checkbox"/> |
| Floor Furnace | <input type="checkbox"/> | Co-Ray-Vac | <input type="checkbox"/> | STANDARD | | | | <input type="checkbox"/> | STANDARD | <input type="checkbox"/> | | | | | STANDARD | <input type="checkbox"/> | | | | |

| | | | | | | | | | | | | | | | | | | | | | | | |
|-----------------|--------------------------|----------|--------------------------|----------------|--|--|--|--------------------------|----------------|--|--|--|--------------------------|-------------|--|--|--|--------------------------|--------------|--|--|--|--------------------------|
| Complete HVAC | <input type="checkbox"/> | No Heat | <input type="checkbox"/> | PLUMBING | | | | A | LIGHTING | | | | A | | | | | | | | | | |
| Refrig. Cooling | <input type="checkbox"/> | Standard | <input type="checkbox"/> | NO PLUMBING | | | | <input type="checkbox"/> | EXTRA FIXTURES | | | | <input type="checkbox"/> | FLUORESCENT | | | | <input type="checkbox"/> | METAL HALIDE | | | | <input type="checkbox"/> |
| | | | | 2 FIXTURE BATH | | | | | STANDARD | | | | <input type="checkbox"/> | SODIUM VAP | | | | <input type="checkbox"/> | STANDARD | | | | <input type="checkbox"/> |
| | | | | 3 FIXTURE BATH | | | | | | | | | | MERCURY VAP | | | | <input type="checkbox"/> | | | | | |

| ITEM | CONST | HT | SIZE X SIZE | FL | AREA | UNITS | AGE | REM | CND | GRD | \$/UNIT | UNADJUSTED \$ | PHY | FC | EC | MARKET VALUE |
|--------------------------------------|-------|----|-------------|----|------|-------|------|-----|-----|-----|---------|---------------|-----|----|----|--------------|
| A 499.033:Garage: Detached Frame/Blo | | | 24 X 26 | 1 | 624 | | 1989 | | A | A | 36.00 | 22,460 | 26 | 0 | 0 | 16,620 |
| | | | | | | | | | | | | | | | | |
| | | | | | | | | | | | | | | | | |
| | | | | | | | | | | | | | | | | |
| | | | | | | | | | | | | | | | | |
| | | | | | | | | | | | | | | | | |
| | | | | | | | | | | | | | | | | |
| | | | | | | | | | | | | | | | | |
| | | | | | | | | | | | | | | | | |
| | | | | | | | | | | | | | | | | |

| ITEM | CONST | HT | SIZE X SIZE | FL | AREA | UNITS | AGE | REM | CND | GRD | \$/UNIT | UNADJUSTED \$ | PHY | FC | EC | MARKET VALUE |
|------------------|-------|----|-------------|----|-------|-------|------|-----|-----|-----|-----------|---------------|-----|----|----|--------------|
| A 530.002:TRIPLX | | | | 1 | 1,405 | 3 | 1904 | | A | A | 34,800.00 | 104,400 | 0 | 0 | 0 | 104,400 |
| 2 499.054:OFP | | | | 1 | 278 | | 1904 | | A | A | 10.00 | 2,780 | 80 | 0 | 0 | 560 |
| 3 901.015:CAN | | | 25 X 21 | 1 | 525 | | 1989 | | A | A | 18.00 | 9,450 | 41 | 0 | 0 | 5,580 |
| | | | | | | | | | | | | | | | | |
| | | | | | | | | | | | | | | | | |
| | | | | | | | | | | | | | | | | |
| | | | | | | | | | | | | | | | | |
| | | | | | | | | | | | | | | | | |
| | | | | | | | | | | | | | | | | |
| | | | | | | | | | | | | | | | | |

| | | | | | | | | | | | | | | | | | | |
|---------------|--|--|--|--|--|--|--|--|--|--|--|--|--|--|------------|--|----------|--|
| AMENITY TOTAL | | | | | | | | | | | | | | | 0 | | | |
| | | | | | | | | | | | | | | | TOTAL IMPR | | *109,540 | |

| | | | | | | | | | | | | | | | | |
|----------|--|--|--|--|--|--|--|--|--|--|--|--|--|--|--|--|
| COMMENTS | | | | | | | | | | | | | | | | |
| | | | | | | | | | | | | | | | | |



27-065100.0000

JEFFERSON TWP-CELINA CORP
 CELINA SD
 08-01-429-001

LEGAL INFORMATION

OLD PLAT
 LOT 61 PT N SD
 LOT#: 61

MARCHAL CONSTRUCTION LLC
 MARCHAL CONSTRUCTION LLC
 5896 WABASH RD
 COLDWATER, OH 45828

| |
|---------------------------|
| Neighborhood CSTR30-30 |
| Map: Block: Card: |
| Bk: Pg: |

COMMENT
 DE23 CHG ATT GAR TO CPY; DESKTOP RVW
 TAX INCENTIVE: TF505

| Sales Data | | | | | | | Date |
|------------|---------|------------|-------------|-------|-------------------------------------|------------|----------|
| Date | Amount | Deed:Conv# | Use | Valid | Lister: | | 03/29/23 |
| 05/06/2014 | 175,000 | | 3:WDC : 246 | 401 | <input checked="" type="checkbox"/> | Pricer: | |
| 07/11/2007 | 0 | | QCE : X : 0 | 447 | <input type="checkbox"/> | Reviewer: | |
| 09/09/1999 | 120,000 | | : A : 0 | 447 | <input checked="" type="checkbox"/> | Final: | |
| | | | | | <input type="checkbox"/> | Call Back: | |
| | | | | | <input type="checkbox"/> | Visit: | |

| VALUATION SUMMARY | | | | |
|------------------------|-----------------|--|--|--|
| VALUE YEAR | | | | |
| REASON FOR CHANGE | | | | |
| ESTIMATED MARKET VALUE | LAND IMPR TOTAL | | | |
| ASSESSED VALUE | LAND IMPR TOTAL | | | |

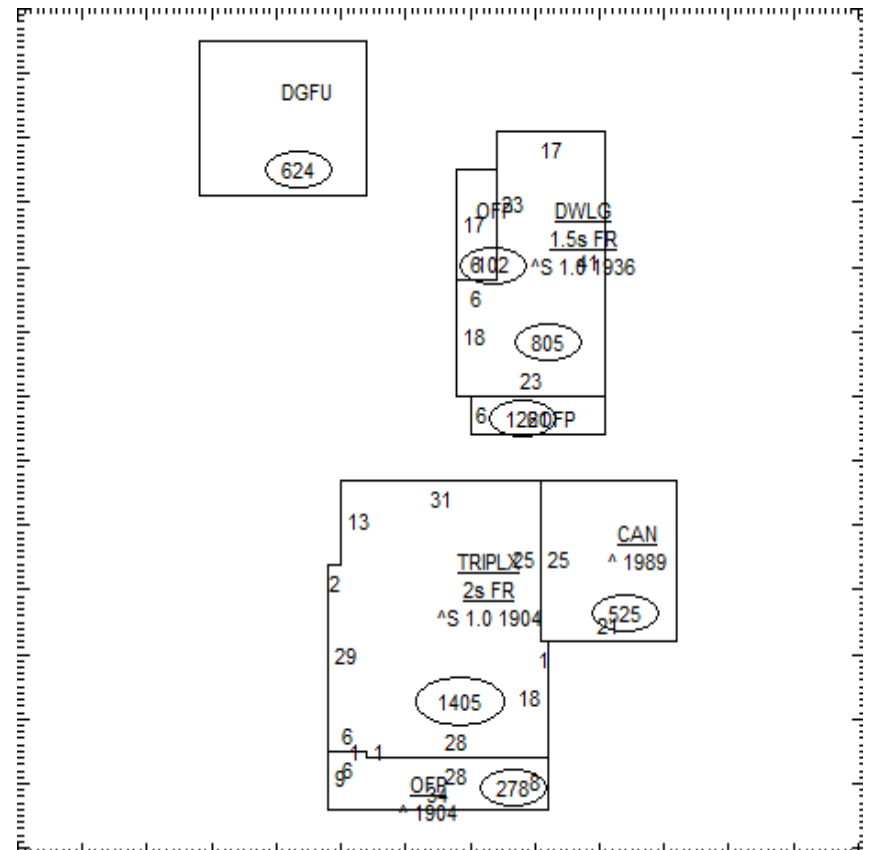

| STREET/ROAD | TOPOGRAPHY | PU-UTILITIES-PR | ZONING |
|---|---|--|--|
| <input checked="" type="checkbox"/> PAVED | <input checked="" type="checkbox"/> LEVEL | <input type="checkbox"/> WATER | <input type="checkbox"/> AG-RES |
| <input type="checkbox"/> GRAVEL | <input type="checkbox"/> HIGH | <input type="checkbox"/> SEWER | <input checked="" type="checkbox"/> COMMERCIAL |
| <input type="checkbox"/> DIRT | <input type="checkbox"/> LOW | <input type="checkbox"/> GAS | <input type="checkbox"/> INDUSTRIAL |
| <input checked="" type="checkbox"/> SIDEWALKS | <input type="checkbox"/> ROLLING | <input type="checkbox"/> ELECTRIC | |
| <input checked="" type="checkbox"/> CURBS | <input type="checkbox"/> STANDARD | <input checked="" type="checkbox"/> STANDARD | |

| INFLUENCE FACTORS | | |
|-------------------|-------------|----------------|
| A. NO ROAD | E. SZ/SHAPE | I. WATER FRONT |
| B. TOPGRHY | F. RESTRICT | J. OTHER/CDU |
| C. Ex Front | G. WOOD LT | |
| D. QUANTITY | H. VACANCY | |

| LAND TYPE | SIZE | M | RATE | C | INF | M | VALUE | C |
|-----------|------|---|------|---|-----|--------|--------|---|
| | | | | | | | | |
| | | | | | | | | |
| | | | | | | | | |
| Totals: | | | | | | 12,800 | | 0 |
| | | | | | | | 12,800 | |

| | | EX WALL | B | ROOFING | B | WINDOW | B | DOORS | B | FOUNDATION | B | FRAMING | B | |
|-----------------------------|------------------|-----------|--------------------------|--------------------------|--------------------------|--------------------------|--------------------------|--------------------------|--------------------------|--------------------------|--------------------------|--------------------------|--------------------------|--------------------------|
| | | STONE | <input type="checkbox"/> | GABLE/HIP | <input type="checkbox"/> | STORE FRT | <input type="checkbox"/> | OVERHEAD | <input type="checkbox"/> | SLAB | <input type="checkbox"/> | PRE ENG | <input type="checkbox"/> | |
| CLASS/QUALITY RANK | | BRICK | <input type="checkbox"/> | SHED/FLAT | <input type="checkbox"/> | CASEMENT | <input type="checkbox"/> | | | CRAWL | <input type="checkbox"/> | STEEL | <input type="checkbox"/> | |
| A) FP STRUCT. STEEL FRAME | 1. BASIC | CON BLK | <input type="checkbox"/> | CON DECK | <input type="checkbox"/> | DBLH | <input type="checkbox"/> | | | PILE/COL | <input type="checkbox"/> | REINF CONC | <input type="checkbox"/> | |
| B) R.C. FRAME | 2. FAIR | WD/MTL | <input type="checkbox"/> | MTL DECK | <input type="checkbox"/> | SLIDE BY | <input type="checkbox"/> | | | REINFOR | <input type="checkbox"/> | CB/MASON | <input type="checkbox"/> | |
| C) MASONRY BEARING WALLS | 3. AVE | ENAM STL | <input type="checkbox"/> | WD DECK | <input type="checkbox"/> | CANOPY | B | | | STEEL | <input type="checkbox"/> | FRAME | <input type="checkbox"/> | |
| D) WD OR STEEL FR EX. WALLS | 4. GOOD | ALUM/VYL | <input type="checkbox"/> | METAL | <input type="checkbox"/> | LIGHTED | <input type="checkbox"/> | STEEL INS | <input type="checkbox"/> | BRICK | <input type="checkbox"/> | POLE | <input type="checkbox"/> | |
| S) METAL M) MILL P) POLE | 5. EXCEL | CON PANEL | <input type="checkbox"/> | ASPH | <input type="checkbox"/> | SOFFITS | <input type="checkbox"/> | WOOD | <input type="checkbox"/> | STONE | <input type="checkbox"/> | TILT UP | <input type="checkbox"/> | |
| TOTAL AREA | PERIMETER | 0 | PLATE GLS | <input type="checkbox"/> | RUBBER | <input type="checkbox"/> | C S W | <input type="checkbox"/> | MTL | <input type="checkbox"/> | CON BLK | <input type="checkbox"/> | SANDWICH | <input type="checkbox"/> |
| # STORIES | STORY HT | | STUCCO | <input type="checkbox"/> | BUILT UP | <input type="checkbox"/> | FACADE | B | GLASS | <input type="checkbox"/> | FRAME | <input type="checkbox"/> | STANDARD | <input type="checkbox"/> |
| AGE | SPRINKLER | | INSULATED | <input type="checkbox"/> | INSULATED | <input type="checkbox"/> | | | STANDARD | <input type="checkbox"/> | STANDARD | <input type="checkbox"/> | | |

| H.V.A.C. | | FLOORS | B | 1 | 2 | 3 | U | PARTITIONS | B | 1 | 2 | 3 | U | INTERIOR FINISH | B | 1 | 2 | 3 | U |
|-----------------|--|---------------------------------------|--------------------------|--------------------------|--------------------------|--------------------------|--------------------------|-------------|--------------------------|--------------------------|--------------------------|--------------------------|--------------------------|-----------------|--------------------------|--------------------------|--------------------------|--------------------------|--------------------------|
| Electric | <input type="checkbox"/> Electric Wall | <input type="checkbox"/> CONCRETE | <input type="checkbox"/> | <input type="checkbox"/> | <input type="checkbox"/> | <input type="checkbox"/> | <input type="checkbox"/> | MASONRY | <input type="checkbox"/> | <input type="checkbox"/> | <input type="checkbox"/> | <input type="checkbox"/> | <input type="checkbox"/> | UNFINISHED | <input type="checkbox"/> | <input type="checkbox"/> | <input type="checkbox"/> | <input type="checkbox"/> | <input type="checkbox"/> |
| Forced Air Unit | <input type="checkbox"/> Hot Water | <input type="checkbox"/> WOOD | <input type="checkbox"/> | <input type="checkbox"/> | <input type="checkbox"/> | <input type="checkbox"/> | <input type="checkbox"/> | WD STUD | <input type="checkbox"/> | <input type="checkbox"/> | <input type="checkbox"/> | <input type="checkbox"/> | <input type="checkbox"/> | FINISH OPEN | <input type="checkbox"/> | <input type="checkbox"/> | <input type="checkbox"/> | <input type="checkbox"/> | <input type="checkbox"/> |
| Hot Water, Rad | <input type="checkbox"/> Space/ Wall Furnace | <input type="checkbox"/> TILE A Q V T | <input type="checkbox"/> | <input type="checkbox"/> | <input type="checkbox"/> | <input type="checkbox"/> | <input type="checkbox"/> | MTL STUD | <input type="checkbox"/> | <input type="checkbox"/> | <input type="checkbox"/> | <input type="checkbox"/> | <input type="checkbox"/> | FINISH DIV | <input type="checkbox"/> | <input type="checkbox"/> | <input type="checkbox"/> | <input type="checkbox"/> | <input type="checkbox"/> |
| Steam | <input type="checkbox"/> Warm & Cld Air | <input type="checkbox"/> CARPET | <input type="checkbox"/> | <input type="checkbox"/> | <input type="checkbox"/> | <input type="checkbox"/> | <input type="checkbox"/> | CEILINGS | B | 1 | 2 | 3 | U | PANEL | <input type="checkbox"/> | <input type="checkbox"/> | <input type="checkbox"/> | <input type="checkbox"/> | <input type="checkbox"/> |
| Ventilation | <input type="checkbox"/> Heat Pump | <input type="checkbox"/> ASPHALT | <input type="checkbox"/> | <input type="checkbox"/> | <input type="checkbox"/> | <input type="checkbox"/> | <input type="checkbox"/> | ACCUT/PANEL | <input type="checkbox"/> | <input type="checkbox"/> | <input type="checkbox"/> | <input type="checkbox"/> | <input type="checkbox"/> | PLASTER / DW | <input type="checkbox"/> | <input type="checkbox"/> | <input type="checkbox"/> | <input type="checkbox"/> | <input type="checkbox"/> |
| Package Unit | <input type="checkbox"/> Ind TW Heat Pump | <input type="checkbox"/> GRAVEL | <input type="checkbox"/> | <input type="checkbox"/> | <input type="checkbox"/> | <input type="checkbox"/> | <input type="checkbox"/> | PLASTER/DW | <input type="checkbox"/> | <input type="checkbox"/> | <input type="checkbox"/> | <input type="checkbox"/> | <input type="checkbox"/> | BLOCK | <input type="checkbox"/> | <input type="checkbox"/> | <input type="checkbox"/> | <input type="checkbox"/> | <input type="checkbox"/> |
| Hot & Cld Water | <input type="checkbox"/> Evaporated Cool | <input type="checkbox"/> DIRT | <input type="checkbox"/> | <input type="checkbox"/> | <input type="checkbox"/> | <input type="checkbox"/> | <input type="checkbox"/> | SUSP/OPEN | <input type="checkbox"/> | <input type="checkbox"/> | <input type="checkbox"/> | <input type="checkbox"/> | <input type="checkbox"/> | GLAZED TILE | <input type="checkbox"/> | <input type="checkbox"/> | <input type="checkbox"/> | <input type="checkbox"/> | <input type="checkbox"/> |
| Floor Furnace | <input type="checkbox"/> Co-Ray-Vac | <input type="checkbox"/> STANDARD | <input type="checkbox"/> | | | | | STANDARD | <input type="checkbox"/> | | | | | STANDARD | <input type="checkbox"/> | | | | |

| Complete HVAC | | PLUMBING | | | | | LIGHTING | | | | | | | |
|--------------------------|----------|---|--|--|--|--|--------------------------------------|--|--|--|--|--------------------------|--------------|--------------------------|
| <input type="checkbox"/> | No Heat | <input type="checkbox"/> NO PLUMBING | | | | | <input type="checkbox"/> FLUORESCENT | | | | | <input type="checkbox"/> | METAL HALIDE | <input type="checkbox"/> |
| <input type="checkbox"/> | Standard | <input type="checkbox"/> 2 FIXTURE BATH | | | | | <input type="checkbox"/> STANDARD | | | | | <input type="checkbox"/> | STANDARD | <input type="checkbox"/> |
| YARD ITEMS | | <input type="checkbox"/> 3 FIXTURE BATH | | | | | <input type="checkbox"/> MERCURY VAP | | | | | <input type="checkbox"/> | | <input type="checkbox"/> |

| ITEM | CONST | HT | SIZE X SIZE | FL | AREA | UNITS | AGE | REM | CND | GRD | \$/UNIT | UNADJUSTED \$ | PHY | FC | EC | MARKET VALUE |
|----------------|-------|----|-------------|----|------|-------|------|-----|-----|-----|---------|---------------|-----|----|----|--------------|
| B 510.110:DWLG | | | | 1 | 805 | | 1936 | | A | A | 86.00 | 69,230 | 59 | 0 | 0 | 28,380 |
| 1 499.054:OFF | | | 17 X 6 | 1 | 102 | | 1936 | | A | A | 10.00 | 1,020 | 59 | 0 | 0 | 420 |
| 2 499.054:OFF | | | 6 X 21 | 1 | 126 | | 1936 | | A | A | 10.00 | 1,260 | 59 | 0 | 0 | 520 |
| | | | | | | | | | | | | | | | | |
| | | | | | | | | | | | | | | | | |
| | | | | | | | | | | | | | | | | |
| | | | | | | | | | | | | | | | | |
| | | | | | | | | | | | | | | | | |
| | | | | | | | | | | | | | | | | |
| | | | | | | | | | | | | | | | | |
| | | | | | | | | | | | | | | | | |
| | | | | | | | | | | | | | | | | |
| | | | | | | | | | | | | | | | | |
| | | | | | | | | | | | | | | | | |

| | | | | | | | | | | | | | | | | |
|---------------|--|--|--|--|--|--|--|--|--|--|--|--|--|--|------------|----------|
| AMENITY TOTAL | | | | | | | | | | | | | | | | 0 |
| | | | | | | | | | | | | | | | TOTAL IMPR | *109,540 |

COMMENTS