

Property Class: 510

Neighborhood
27502740-04 -

Map: 05A

Block:

Card: 84

Bk: Pg:

JEFFERSON TWP-CELINA CORP / CELINA SD

06-32-205-012

27-026951.2700

STELZER DANIEL J & LORRAINE M TRUSTEES

STELZER DANIEL J & LORRAINE M TRUSTEES

2022 EAGLEBROOKE PKWY

CELINA, OH 45822

LEGAL INFORMATION

EAGLEBROOKE ESTATES

SECTION 1

LOT#: 26

	OWNERSHIP	ADDRESS	CITY	STATE	ZIP	DATE	AMOUNT	DEED:CONV#	JS	VALID
1	STELZER DANIEL J &	2022 EAGLEBROOKE PKWY	CELINA	OH	45822	09/28/2020	419,000	WDC : 701	<input type="checkbox"/>	<input checked="" type="checkbox"/>
2	WALLEY CHRISTOPHER B &	2020 EAGLEBROOKE PKWY	CELINA	OH	45822	09/10/2015	376,000	WDC : 610	<input type="checkbox"/>	<input checked="" type="checkbox"/>
3	ROSENGARTEN TIMOTHY J &	2022 EAGLEBROOKE PKWY	CELINA	OH	45822	07/31/2012	355,300	WDC : A : 432	<input type="checkbox"/>	<input checked="" type="checkbox"/>

X: TTO LISTER: DF DATE: 03/16/2005 TIME: 12:00:00 AM LETTER LETTER REC'D GIS CODE

STREET/ROAD		TOPOGRAPHY	PU-UTILITIES-PR		NEIGHBORHOOD		INFLUENCE FACTORS				PROPERTY LOCATION	
<input checked="" type="checkbox"/> PAVED	<input checked="" type="checkbox"/> LEVEL	<input type="checkbox"/> WATER	<input type="checkbox"/> IMPROVING	<input type="checkbox"/> A. NO ROAD	<input type="checkbox"/> F. RESTRICT	2022 EAGLEBROOKE PKWY, CELINA						
<input type="checkbox"/> GRAVEL	<input type="checkbox"/> HIGH	<input type="checkbox"/> SEWER	<input type="checkbox"/> STATIC	<input type="checkbox"/> B. TOPGRHY	<input type="checkbox"/> G. WOOD LT	COMMENT						
<input type="checkbox"/> DIRT	<input type="checkbox"/> LOW	<input type="checkbox"/> GAS	<input type="checkbox"/> DECLINING	<input type="checkbox"/> C. Ex Front	<input type="checkbox"/> H. VACANCY	TY2022:Net Gen=\$5,213.32, Other						
<input type="checkbox"/> SIDEWALKS	<input type="checkbox"/> ROLLING	<input type="checkbox"/> ELECTRIC	<input type="checkbox"/> OLD	<input type="checkbox"/> D. QUANTITY	<input type="checkbox"/> I. WATER FRONT	Assessment=\$0.00						
<input type="checkbox"/> CURBS	<input type="checkbox"/> STANDARD	<input checked="" type="checkbox"/> STANDARD	<input type="checkbox"/> STANDARD	<input type="checkbox"/> E. SZ/SHAPE	<input type="checkbox"/> J. OTHER/CDU	DE15 ADD FN BSMNT PER DATA MAILER						
LAND COMPUTATIONS												
LAND TYPE		SIZE		M RATE C		INF		M VALUE		C		
F:Front		F120 D174		ST505 DP107 ADJ540				64,800		0		
TOTAL								64,800		0		

VALUATION SUMMARY								
VALUE YEAR	2023	2020	2020	2017				
REASON FOR CHANGE	RAPP	RAPP	MISC	RAPP				
APPRAISED VALUE	<u>LAND</u>	64,800	56,500	50,000	50,000			
	<u>IMPR</u>	324,500	273,300	250,800	247,500			
	<u>TOTAL</u>	389,300	329,800	300,800	297,500			
ASSESSED VALUE	<u>LAND</u>	22,680	19,780	17,500	17,500			
	<u>IMPR</u>	113,580	95,660	87,780	86,630			
	<u>TOTAL</u>	136,260	115,440	105,280	104,130			

OCCUPANCY		EXTERIOR	
<input checked="" type="checkbox"/> SF	<input type="checkbox"/> DU	<input type="checkbox"/> TR	<input type="checkbox"/> WOOD
<input type="checkbox"/> CONVERSION		<input type="checkbox"/> STUCCO	
BUILDING TYPE		<input type="checkbox"/> ALM/VYNL	
<input type="checkbox"/> MOBILE HOME		<input type="checkbox"/> CONC BLK	
<input type="checkbox"/> BI/TR LEVEL		<input type="checkbox"/> METAL	
<input type="checkbox"/> MOD/MAN		<input checked="" type="checkbox"/> BRICK	
<input type="checkbox"/>		<input type="checkbox"/> STONE	

ROOFING		ROOF TYPE	
<input type="checkbox"/> METAL		<input type="checkbox"/> GABLE	
<input type="checkbox"/> SLT/TLE		<input checked="" type="checkbox"/> HIP	
<input checked="" type="checkbox"/> SHINGLES		<input type="checkbox"/> GAMBREL	
<input type="checkbox"/> SHAKES		<input type="checkbox"/> MANSARD	
<input type="checkbox"/> COMPOSITE		<input type="checkbox"/> FLAT	

FLOORS		B	1	2	3	U
CONCRETE	<input checked="" type="checkbox"/>	<input type="checkbox"/>	<input type="checkbox"/>	<input type="checkbox"/>	<input type="checkbox"/>	<input type="checkbox"/>
WOOD	<input type="checkbox"/>	<input checked="" type="checkbox"/>	<input type="checkbox"/>	<input type="checkbox"/>	<input type="checkbox"/>	<input type="checkbox"/>
TILE/COMPO	<input type="checkbox"/>	<input checked="" type="checkbox"/>	<input type="checkbox"/>	<input type="checkbox"/>	<input type="checkbox"/>	<input type="checkbox"/>
CARPET	<input checked="" type="checkbox"/>	<input checked="" type="checkbox"/>	<input type="checkbox"/>	<input type="checkbox"/>	<input type="checkbox"/>	<input type="checkbox"/>

INT. FINISH		B	1	2	3	U
PLASTER/DW	<input checked="" type="checkbox"/>	<input checked="" type="checkbox"/>	<input type="checkbox"/>	<input type="checkbox"/>	<input type="checkbox"/>	<input type="checkbox"/>
PANELING	<input type="checkbox"/>	<input type="checkbox"/>	<input type="checkbox"/>	<input type="checkbox"/>	<input type="checkbox"/>	<input type="checkbox"/>
UNFINISHED	<input checked="" type="checkbox"/>	<input type="checkbox"/>	<input type="checkbox"/>	<input type="checkbox"/>	<input type="checkbox"/>	<input type="checkbox"/>

ACCOMMODATIONS	
# OF ROOMS	3 6
BEDROOMS	1 3
FIREPLACES	1
HEAT & AC	B 1 2 3 U

NO HEAT	<input type="checkbox"/>	<input type="checkbox"/>	<input type="checkbox"/>	<input type="checkbox"/>	<input type="checkbox"/>
CTRL HEAT	<input checked="" type="checkbox"/>	<input checked="" type="checkbox"/>	<input type="checkbox"/>	<input type="checkbox"/>	<input type="checkbox"/>
HW/STEAM	<input type="checkbox"/>	<input type="checkbox"/>	<input type="checkbox"/>	<input type="checkbox"/>	<input type="checkbox"/>
ELECTRIC	<input type="checkbox"/>	<input type="checkbox"/>	<input type="checkbox"/>	<input type="checkbox"/>	<input type="checkbox"/>
HEAT PUMP	<input type="checkbox"/>	<input type="checkbox"/>	<input type="checkbox"/>	<input type="checkbox"/>	<input type="checkbox"/>
FLR/WALL	<input type="checkbox"/>	<input type="checkbox"/>	<input type="checkbox"/>	<input type="checkbox"/>	<input type="checkbox"/>
STVE/SPCE	<input type="checkbox"/>	<input type="checkbox"/>	<input type="checkbox"/>	<input type="checkbox"/>	<input type="checkbox"/>
GEO THERMAL	<input type="checkbox"/>	<input type="checkbox"/>	<input type="checkbox"/>	<input type="checkbox"/>	<input type="checkbox"/>
OUTSIDE	<input type="checkbox"/>	<input type="checkbox"/>	<input type="checkbox"/>	<input type="checkbox"/>	<input type="checkbox"/>
CTRL A/C	<input checked="" type="checkbox"/>	<input checked="" type="checkbox"/>	<input type="checkbox"/>	<input type="checkbox"/>	<input type="checkbox"/>

PLUMBING	BASE		<input checked="" type="checkbox"/>
X FULL BATH	1	1	
X HALF BATH		1	
X FIXTURES			

FLOOR	AREA	CONST	VALUE
1	2148	BRK	263,370
BSMT	2148		30,720
SUBTOTAL			294,090
MULTI-FAMILY #	0		0
BUILDING TYPE	100%		0
BSMT FINISH	1,611 S.F.		23,040
FIREPLACE #	1		4,400
HEATING	0 S.F.		0
AIR COND	3,759 S.F.		6,200
PLUMBING #	8		9,680
GARAGES & CARPORTS			22,800
EXTRA FEATURES			10,700
SUBTOTAL			370,910
GRADE FACTOR			120 %
UNADJUSTED VALUE			445,090
FACTOR			100 %

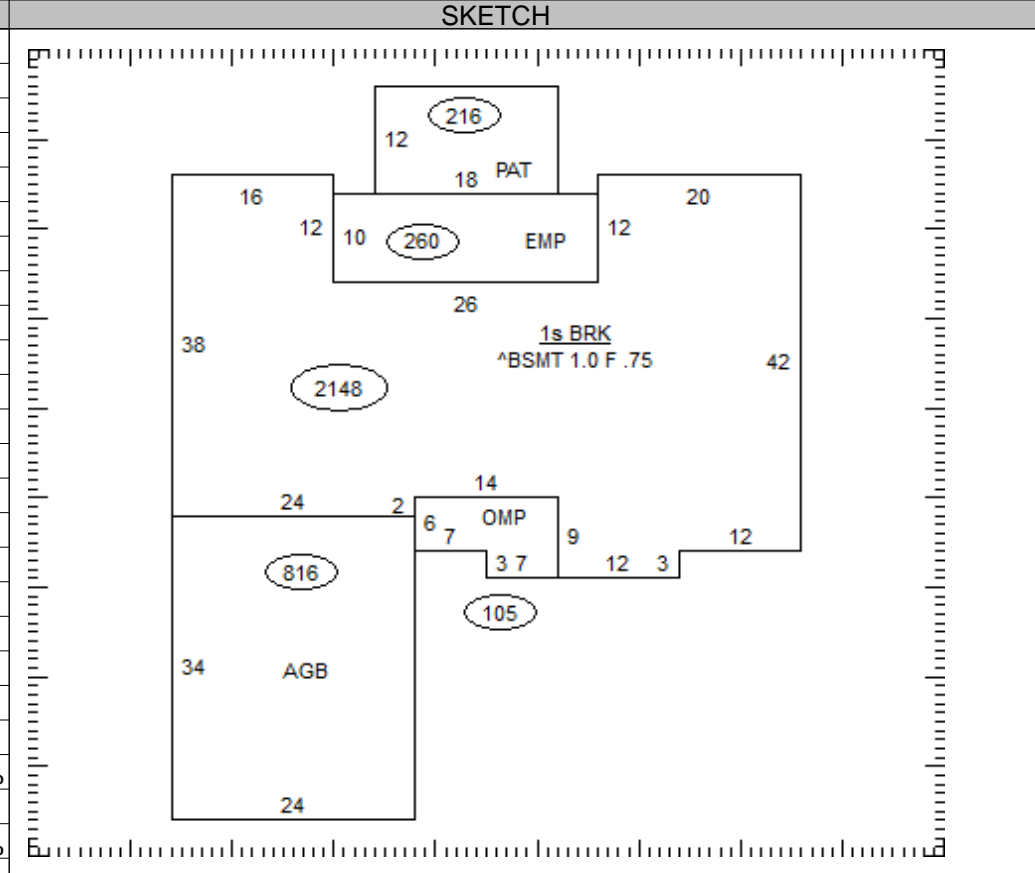

OCCUPANCY	ST.HT	SIZE	AREA	GRADE	PRICE	AGE	REMD	CND	UNADJ VAL	PHYS	PHYS VAL	FUNC	TRUE VAL
DWELLING	1	SK	2,148	B		1998		A	445,090	19	360,520		324,500
1													
2													
3													
4													
5													
6													
7													
8													
9													
10													
11													

27-026951.2700

TOTAL 324,500

COMMENTS

Dwelling has an Economic Factor of 90%

JEFFERSON TWP-CELINA CORP / CELINA SD

06-32-205-012

Property Class: 510

Neighborhood

27502740-04 -

Map: 05A

Block:

Card: 84

Bk: Pg:

27-026951.2700

STELZER DANIEL J & LORRAINE M TRUSTEES

STELZER DANIEL J & LORRAINE M TRUSTEES

2022 EAGLEBROOKE PKWY

CELINA, OH 45822

LEGAL INFORMATION

EAGLEBROOKE ESTATES

SECTION 1

LOT#: 26

	OWNERSHIP	ADDRESS	CITY	STATE	ZIP	DATE	AMOUNT	DEED:CONV#	JS	VALID
1	SMITH DENNIS W & TERESA L	2022 EAGLEBROOKE PKWY	CELINA	OH	45822-9397	06/19/1998	37,000	: A : 0	<input type="checkbox"/>	<input checked="" type="checkbox"/>
2							0	0	<input type="checkbox"/>	<input type="checkbox"/>
3							0	0	<input type="checkbox"/>	<input type="checkbox"/>

X: TTO LISTER: DF DATE: 03/16/2005 TIME: 12:00:00 AM LETTER LETTER REC'D GIS CODE

STREET/ROAD	TOPOGRAPHY	PU-UTILITIES-PR	NEIGHBORHOOD	INFLUENCE FACTORS				PROPERTY LOCATION
<input checked="" type="checkbox"/> PAVED	<input checked="" type="checkbox"/> LEVEL	<input type="checkbox"/> WATER	<input type="checkbox"/> IMPROVING	<input type="checkbox"/> A. NO ROAD	<input type="checkbox"/> F. RESTRICT	2022 EAGLEBROOKE PKWY, CELINA		
<input type="checkbox"/> GRAVEL	<input type="checkbox"/> HIGH	<input type="checkbox"/> SEWER	<input type="checkbox"/> STATIC	<input type="checkbox"/> B. TOPGRHY	<input type="checkbox"/> G. WOOD LT	COMMENT		
<input type="checkbox"/> DIRT	<input type="checkbox"/> LOW	<input type="checkbox"/> GAS	<input type="checkbox"/> DECLINING	<input type="checkbox"/> C. Ex Front	<input type="checkbox"/> H. VACANCY			
<input type="checkbox"/> SIDEWALKS	<input type="checkbox"/> ROLLING	<input type="checkbox"/> ELECTRIC	<input type="checkbox"/> OLD	<input type="checkbox"/> D. QUANTITY	<input type="checkbox"/> I. WATER FRONT			
<input type="checkbox"/> CURBS	<input type="checkbox"/> STANDARD	<input checked="" type="checkbox"/> STANDARD	<input type="checkbox"/> STANDARD	<input type="checkbox"/> E. SZ/SHAPE	<input type="checkbox"/> J. OTHER/CDU			

LAND COMPUTATIONS

LAND TYPE	SIZE	M	RATE	C	INF	M	VALUE	C
TOTAL							64,800	0

VALUATION SUMMARY

VALUE YEAR							
REASON FOR CHANGE							
APPRaised	<u>LAND</u>						
VALUE	<u>IMPR</u>						
	<u>TOTAL</u>						
ASSESSED	<u>LAND</u>						
VALUE	<u>IMPR</u>						
	<u>TOTAL</u>						

OCCUPANCY	EXTERIOR	FLOOR	AREA	CONST	VALUE
<input type="checkbox"/> SF <input type="checkbox"/> DU <input type="checkbox"/> TR	<input type="checkbox"/> WOOD				
<input type="checkbox"/> CONVERSION	<input type="checkbox"/> STUCCO				
BUILDING TYPE	<input type="checkbox"/> ALM/VYNL				
<input type="checkbox"/> MOBILE HOME	<input type="checkbox"/> CONC BLK				
<input type="checkbox"/> BI/TR LEVEL	<input type="checkbox"/> METAL				
<input type="checkbox"/> MOD/MAN	<input type="checkbox"/> BRICK				
<input type="checkbox"/> _____	<input type="checkbox"/> STONE				
ROOFING	ROOF TYPE				
<input type="checkbox"/> METAL	<input type="checkbox"/> GABLE				
<input type="checkbox"/> SLT/TLE	<input type="checkbox"/> HIP				
<input type="checkbox"/> SHINGLES	<input type="checkbox"/> GAMBREL				
<input type="checkbox"/> SHAKES	<input type="checkbox"/> MANSARD				
<input type="checkbox"/> COMPOSITE	<input type="checkbox"/> FLAT				

SUBTOTAL					0
MULTI-FAMILY #	0				0
BUILDING TYPE	000%				0
BSMT FINISH	0 S.F.				0
FIREPLACE #	0				0
HEATING	0 S.F.				0
AIR COND	0 S.F.				0
PLUMBING #	0				0
GARAGES & CARPORTS					0
EXTRA FEATURES					0
SUBTOTAL					0
GRADE FACTOR					%
UNADJUSTED VALUE					0
FACTOR					%

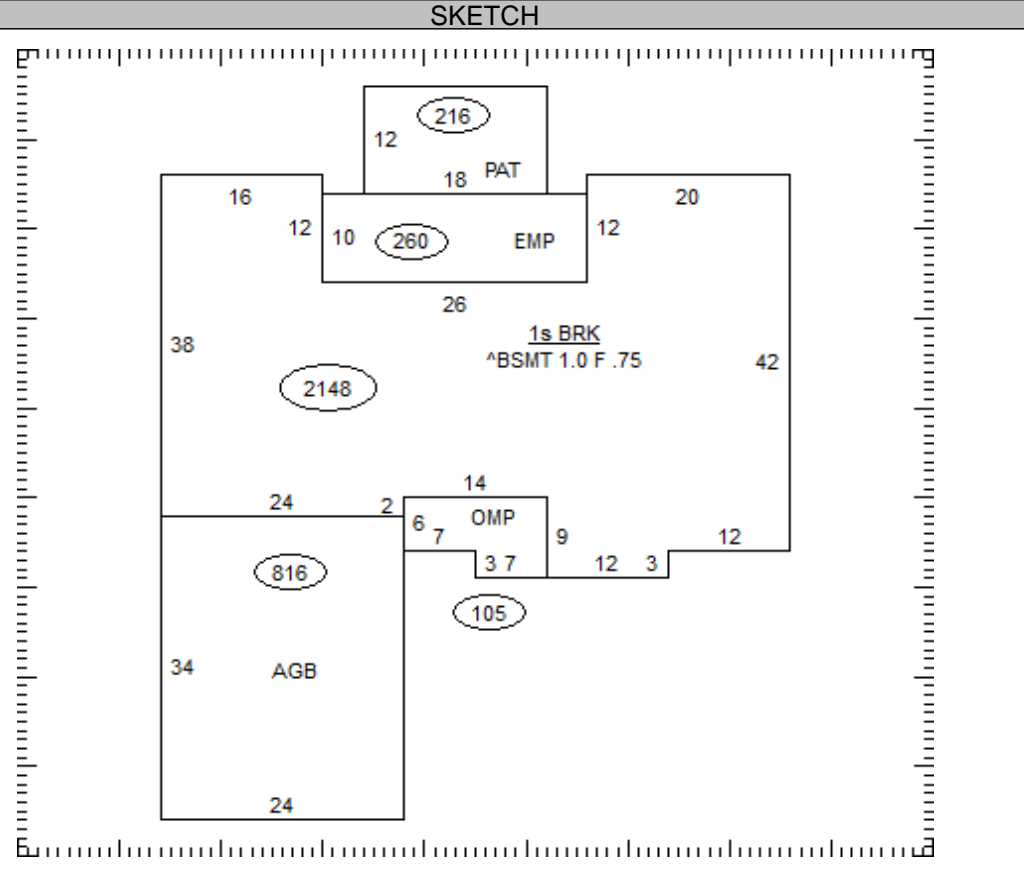

OCCUPANCY	ST.HT	SIZE	AREA	GRADE	PRICE	AGE	REMD	CND	UNADJ VAL	PHYS	PHYS VAL	FUNC	TRUE VAL
DWELLING		SK											
1													
2													
3													
4													
5													
6													
7													
8													
9													
10													
11													

27-026951.2700

TOTAL 0

COMMENTS