

Property Address: 2000 LEGACY LN

DTE Code: 400



\*27-026900.0700\*

JEFFERSON TWP-CELINA CORP  
CELINA SD  
06-32-426-005

**LEGAL INFORMATION**

N 1/2 SE Acres:5.3630

RTS: 003-05-32  
**CELINA APARTMENT GROUP LLC**  
CELINA APARTMENT GROUP LLC  
6781 HELLWARTH RD  
CELINA, OH 45822

Neighborhood CSTR70-70
Map:
Block:
Bk: Pg:

**COMMENT**  
Tax Incentive Exempt Parcel: 27-026900.070K (TY2022 L=188,550; B=0; T=188,550)  
TY2022:Net Gen=\$253.18, Other Assessment=\$3,554.64  
NC24 APARTMENT BUILDINGS/SEE PRINTS/sketch only for tax estimate, please review  
DE22 AC COR PER MAPPING  
2004 BASE VALUES: L:\$13,430 B:\$0 T:\$13,430  
2022 DUPL VALUES: L:\$201,980 B:\$0 T:\$201,980  
2023 DUPL VALUES: L: \$128,710 B:\$0 T:\$128,710

Sales Data							Date
Date	Amount	Deed:Conv#	Use	Valid	Lister:	TR	03/21/22
11/01/2022	0		QCE : X : 0	400	<input type="checkbox"/>	Pricer:	
12/18/2019	461,500		WDC : 867	400	<input checked="" type="checkbox"/>	Reviewer:	
02/09/2004	0		QCE : X : 0	400	<input type="checkbox"/>	Final:	
07/26/2000	595,700		: A-M : 0	400	<input type="checkbox"/>	Call Back:	
					<input type="checkbox"/>	Visit:	

VALUATION SUMMARY				
VALUE YEAR		* 2023	* 2023	* 2023
REASON FOR CHANGE		RAPP	MISC	MISC
ESTIMATED MARKET VALUE	LAND IMPR TOTAL	13,430	13,430	13,430
ASSESSED VALUE	LAND IMPR TOTAL	4,700	4,700	4,700

LAND TYPE	SIZE	M	RATE	C	INF	M	VALUE	C
1:Primary	A:5.363		80,000				128,710	0
Totals:	Total Acres 5.3630						13,430	0

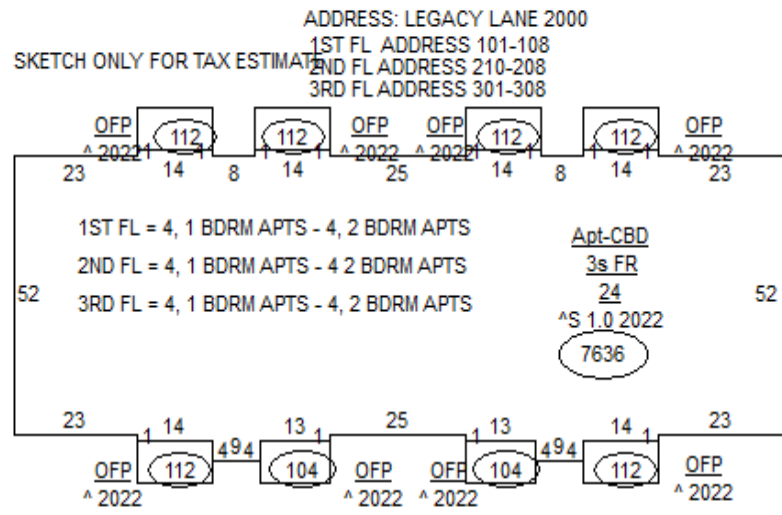

STREET/ROAD	TOPOGRAPHY	PU-UTILITIES-PR	ZONING
<input type="checkbox"/> PAVED	<input type="checkbox"/> LEVEL	<input type="checkbox"/> WATER	<input type="checkbox"/> AG-RES
<input type="checkbox"/> GRAVEL	<input type="checkbox"/> HIGH	<input type="checkbox"/> SEWER	<input checked="" type="checkbox"/> COMMERCIAL
<input type="checkbox"/> DIRT	<input type="checkbox"/> LOW	<input type="checkbox"/> GAS	<input type="checkbox"/> INDUSTRIAL
<input type="checkbox"/> SIDEWALKS	<input type="checkbox"/> ROLLING	<input type="checkbox"/> ELECTRIC	
<input type="checkbox"/> CURBS	<input type="checkbox"/> STANDARD	<input checked="" type="checkbox"/> STANDARD	

INFLUENCE FACTORS		
A. NO ROAD	E. SZ/SHAPE	I. WATER FRONT
B. TOPGRHY	F. RESTRICT	J. OTHER/CDU
C. Ex Front	G. WOOD LT	
D. QUANTITY	H. VACANCY	



Property Address: 2000 LEGACY LN

DTE Code: 400



\*27-026900.0700\*

JEFFERSON TWP-CELINA CORP  
CELINA SD  
06-32-426-005

**LEGAL INFORMATION**

N 1/2 SE Acres:5.3630

RTS: 003-05-32  
**CELINA APARTMENT GROUP LLC**  
CELINA APARTMENT GROUP LLC  
6781 HELLWARTH RD  
CELINA, OH 45822

Neighborhood CSTR70-70
Map:
Block:
Bk: Pg:

COMMENT  
TAX INCENTIVE: TF503

ADDRESS: LEGACY LANE 2000  
1ST FL ADDRESS 101-108  
2ND FL ADDRESS 210-208  
3RD FL ADDRESS 301-308  
SKETCH ONLY FOR TAX ESTIMATE

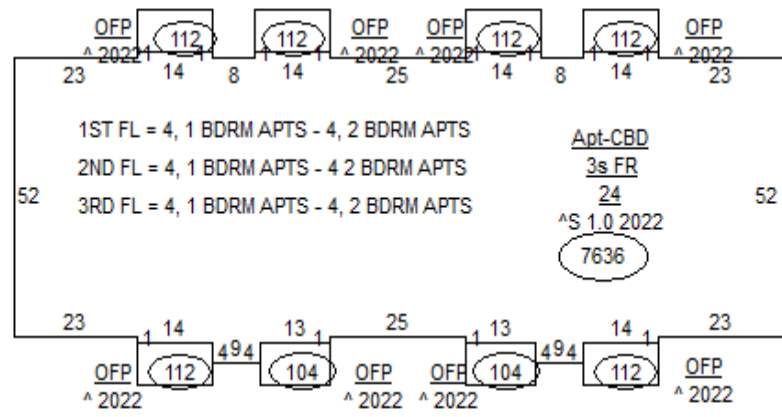

Sales Data							Date
Date	Amount	Deed:Conv#	Use	Valid	Lister: TR		03/21/22
07/26/2000	595,700		: A-M : 0 400	<input type="checkbox"/>	Pricer:		
				<input type="checkbox"/>	Reviewer:		
				<input type="checkbox"/>	Final:		
				<input type="checkbox"/>	Call Back:		
				<input type="checkbox"/>	Visit:		

VALUATION SUMMARY				
VALUE YEAR		* 2022	* 2020	* 2017
REASON FOR CHANGE		MISC	RAPP	RAPP
ESTIMATED MARKET VALUE	LAND	13,430	13,430	13,430
	IMPR	0	0	0
	TOTAL	13,430	13,430	13,430
ASSESSED VALUE	LAND	4,700	4,700	4,700
	IMPR	0	0	0
	TOTAL	4,700	4,700	4,700

STREET/ROAD	TOPOGRAPHY	PU-UTILITIES-PR	ZONING
<input type="checkbox"/> PAVED	<input type="checkbox"/> LEVEL	<input type="checkbox"/> WATER	<input type="checkbox"/> AG-RES
<input type="checkbox"/> GRAVEL	<input type="checkbox"/> HIGH	<input type="checkbox"/> SEWER	<input checked="" type="checkbox"/> COMMERCIAL
<input type="checkbox"/> DIRT	<input type="checkbox"/> LOW	<input type="checkbox"/> GAS	<input type="checkbox"/> INDUSTRIAL
<input type="checkbox"/> SIDEWALKS	<input type="checkbox"/> ROLLING	<input type="checkbox"/> ELECTRIC	
<input type="checkbox"/> CURBS	<input type="checkbox"/> STANDARD	<input checked="" type="checkbox"/> STANDARD	

INFLUENCE FACTORS		
A. NO ROAD	E. SZ/SHAPE	I. WATER FRONT
B. TOPGRHY	F. RESTRICT	J. OTHER/CDU
C. Ex Front	G. WOOD LT	
D. QUANTITY	H. VACANCY	

LAND TYPE	SIZE	M	RATE	C	INF	M	VALUE	C
Totals:	Total Acres 5.3630					13,430	0	13,430

