

Property Address: 715 S SUGAR ST, CELINA

DTE Code: 455



27-010100.0000

JEFFERSON TWP-CELINA CORP
CELINA SD
08-01-476-001

LEGAL INFORMATION

SE SE Acres:4.7750

RTS: 002-06-01
NOW INVESTMENTS LLC
NOW INVESTMENTS LLC
8744 NOW RD
CELINA, OH 45822

| | |
|------------------------|-----|
| Neighborhood CLAK27 | |
| Map: | |
| Block: | |
| Card: | |
| Bk: | Pg: |

COMMENT
Tax Incentive Exempt Parcel: 27-010100.000K (TY2022 L=0; B=222,880; T=222,880)
TY2022:Net Gen=\$8,337.96, Other Assessment=\$4,202.10
2004 BASE VALUES: L:95,600 / B:346,660 / T:442,260
2020 DUPL VALUES: L:227,770 B:437,370 T:\$665,514
2023 DUPL VALUES:L:\$249,260 B:\$702980 T:\$952240
CASE LEASING McGUIRE TOWING
CRUISING AMERICA RV SERVICE CO//BLDGS NOT FULLY OCC 30% FNC
DE17 TTO: COR TIF CALC/ADJ FNC; ONLY 40 X 64 GAR VACANT

| Sales Data | | | | | | | Date |
|------------|---------|------------|-----------|-------|--------------------------|------------|----------|
| Date | Amount | Deed:Conv# | Use | Valid | Lister: | DL | 04/07/17 |
| 10/09/2020 | 690,000 | | WDC : 746 | 455 | ■ | Pricer: | |
| 07/15/2003 | 400,000 | | : A : 0 | 455 | ■ | Reviewer: | |
| | | | | | <input type="checkbox"/> | Final: | |
| | | | | | <input type="checkbox"/> | Call Back: | |
| | | | | | <input type="checkbox"/> | Visit: | |

| VALUATION SUMMARY | | | |
|-------------------|---------|---------|---------|
| VALUE YEAR | * 2023 | * 2020 | * 2017 |
| REASON FOR CHANGE | RAPP | RAPP | RAPP |
| ESTIMATED | 95,600 | 95,600 | 95,600 |
| MARKET VALUE | 346,660 | 346,660 | 346,660 |
| | TOTAL | 442,260 | 442,260 |
| ASSESSED | 33,460 | 33,460 | 33,460 |
| VALUE | 121,330 | 121,330 | 121,330 |
| | TOTAL | 154,790 | 154,790 |

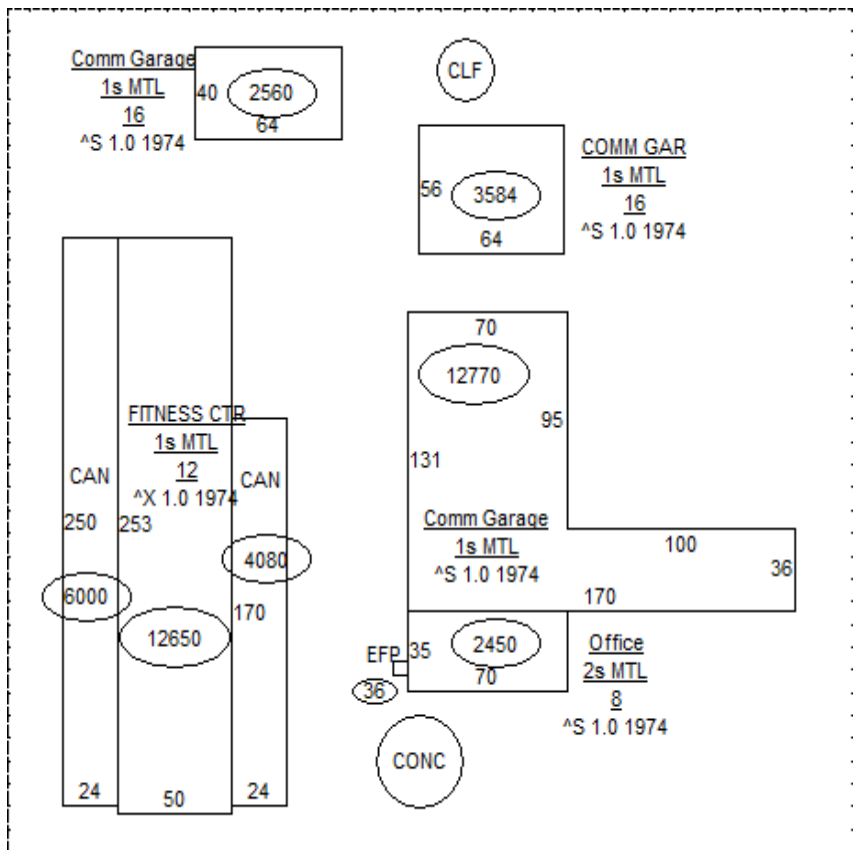

| STREET/ROAD | TOPOGRAPHY | PU-UTILITIES-PR | ZONING |
|---|---|--|--|
| <input checked="" type="checkbox"/> PAVED | <input checked="" type="checkbox"/> LEVEL | <input type="checkbox"/> WATER | <input type="checkbox"/> AG-RES |
| <input type="checkbox"/> GRAVEL | <input type="checkbox"/> HIGH | <input type="checkbox"/> SEWER | <input checked="" type="checkbox"/> COMMERCIAL |
| <input type="checkbox"/> DIRT | <input type="checkbox"/> LOW | <input type="checkbox"/> GAS | <input type="checkbox"/> INDUSTRIAL |
| <input type="checkbox"/> SIDEWALKS | <input type="checkbox"/> ROLLING | <input type="checkbox"/> ELECTRIC | |
| <input type="checkbox"/> CURBS | <input type="checkbox"/> STANDARD | <input checked="" type="checkbox"/> STANDARD | |

| INFLUENCE FACTORS | | |
|-------------------|-------------|----------------|
| A. NO ROAD | E. SZ/SHAPE | I. WATER FRONT |
| B. TOPGRHY | F. RESTRICT | J. OTHER/CDU |
| C. Ex Front | G. WOOD LT | |
| D. QUANTITY | H. VACANCY | |

| LAND TYPE | SIZE | M | RATE | C | INF | M | VALUE | C |
|-----------|--------------------|---------|------|---|-------|---------|-------|---|
| 1:Primary | A:4.775 | 100,000 | | | J:0.1 | 249,260 | | 0 |
| Totals: | Total Acres 4.7750 | | | | | 95,600 | | 0 |

| | | | | | | | | | | | | | | |
|-----------------------------|------------------|-----------|-------------------------------------|-------------------------------------|-------------------------------------|-------------------------------------|-------------------------------------|--------------------------|-------------------------------------|--------------------------|-------------------------------------|--------------------------|-------------------------------------|--------------------------|
| | | EX WALL | A | ROOFING | A | WINDOW | A | DOORS | A | FOUNDATION | A | FRAMING | A | |
| | | STONE | <input type="checkbox"/> | GABLE/HIP | <input checked="" type="checkbox"/> | STORE FRT | <input type="checkbox"/> | OVERHEAD | <input type="checkbox"/> | SLAB | <input checked="" type="checkbox"/> | PRE ENG | <input checked="" type="checkbox"/> | |
| CLASS/QUALITY RANK | | BRICK | <input type="checkbox"/> | SHED/FLAT | <input type="checkbox"/> | CASEMENT | <input checked="" type="checkbox"/> | | | CRAWL | <input type="checkbox"/> | STEEL | <input checked="" type="checkbox"/> | |
| A) FP STRUCT. STEEL FRAME | 1. BASIC | CON BLK | <input type="checkbox"/> | CON DECK | <input type="checkbox"/> | DBLH | <input type="checkbox"/> | | | PILE/COL | <input type="checkbox"/> | REINF CONC | <input type="checkbox"/> | |
| B) R.C. FRAME | 2. FAIR | WD/MTL | <input type="checkbox"/> | MTL DECK | <input type="checkbox"/> | SLIDE BY | <input type="checkbox"/> | | | REINFOR | <input type="checkbox"/> | CB/MASON | <input type="checkbox"/> | |
| C) MASONRY BEARING WALLS | 3. AVE | ENAM STL | <input checked="" type="checkbox"/> | WD DECK | <input type="checkbox"/> | CANOPY | A | | | STEEL | <input type="checkbox"/> | FRAME | <input type="checkbox"/> | |
| D) WD OR STEEL FR EX. WALLS | 4. GOOD | ALUM/VYL | <input type="checkbox"/> | METAL | <input checked="" type="checkbox"/> | LIGHTED | <input type="checkbox"/> | STEEL INS | <input checked="" type="checkbox"/> | BRICK | <input type="checkbox"/> | POLE | <input type="checkbox"/> | |
| S) METAL M) MILL P) POLE | 5. EXCEL | CON PANEL | <input type="checkbox"/> | ASPH | <input type="checkbox"/> | SOFFITS | <input type="checkbox"/> | WOOD | <input type="checkbox"/> | STONE | <input type="checkbox"/> | TILT UP | <input type="checkbox"/> | |
| TOTAL AREA | PERIMETER | 0 | PLATE GLS | <input type="checkbox"/> | RUBBER | <input type="checkbox"/> | C S W | <input type="checkbox"/> | MTL | <input type="checkbox"/> | CON BLK | <input type="checkbox"/> | SANDWICH | <input type="checkbox"/> |
| # STORIES | STORY HT | 16 | STUCCO | <input type="checkbox"/> | BUILT UP | <input type="checkbox"/> | FACADE | A | GLASS | <input type="checkbox"/> | FRAME | <input type="checkbox"/> | STANDARD | <input type="checkbox"/> |
| AGE | SPRINKLER | | INSULATED | <input checked="" type="checkbox"/> | INSULATED | <input checked="" type="checkbox"/> | | | STANDARD | <input type="checkbox"/> | STANDARD | <input type="checkbox"/> | | |

| | | | | | | | | | | | | | | | | | | | | | |
|-----------------|---|--------------------------|--------------|--------------------------|-------------------------------------|--------------------------|--------------------------|--------------------------|--------------------------|--------------------------|-----------------|--------------------------|-------------------------------------|--------------------------|--------------------------|--------------|--------------------------|-------------------------------------|--------------------------|--------------------------|--------------------------|
| H.V.A.C. | | FLOORS | | | | | PARTITIONS | | | | | INTERIOR FINISH | | | | | | | | | |
| Electric | <input type="checkbox"/> Electric Wall | <input type="checkbox"/> | CONCRETE | <input type="checkbox"/> | <input checked="" type="checkbox"/> | <input type="checkbox"/> | <input type="checkbox"/> | <input type="checkbox"/> | <input type="checkbox"/> | <input type="checkbox"/> | MASONRY | <input type="checkbox"/> | <input checked="" type="checkbox"/> | <input type="checkbox"/> | <input type="checkbox"/> | UNFINISHED | <input type="checkbox"/> | <input checked="" type="checkbox"/> | <input type="checkbox"/> | <input type="checkbox"/> | <input type="checkbox"/> |
| Forced Air Unit | <input checked="" type="checkbox"/> Hot Water | <input type="checkbox"/> | WOOD | <input type="checkbox"/> | <input type="checkbox"/> | <input type="checkbox"/> | <input type="checkbox"/> | <input type="checkbox"/> | <input type="checkbox"/> | <input type="checkbox"/> | WD STUD | <input type="checkbox"/> | <input checked="" type="checkbox"/> | <input type="checkbox"/> | <input type="checkbox"/> | FINISH OPEN | <input type="checkbox"/> | <input type="checkbox"/> | <input type="checkbox"/> | <input type="checkbox"/> | <input type="checkbox"/> |
| Hot Water, Rad | <input type="checkbox"/> Space/ Wall Furnace | <input type="checkbox"/> | TILE A Q V T | <input type="checkbox"/> | <input type="checkbox"/> | <input type="checkbox"/> | <input type="checkbox"/> | <input type="checkbox"/> | <input type="checkbox"/> | <input type="checkbox"/> | MTL STUD | <input type="checkbox"/> | <input type="checkbox"/> | <input type="checkbox"/> | <input type="checkbox"/> | FINISH DIV | <input type="checkbox"/> | <input type="checkbox"/> | <input type="checkbox"/> | <input type="checkbox"/> | <input type="checkbox"/> |
| Steam | <input type="checkbox"/> Warm & Cld Air | <input type="checkbox"/> | CARPET | <input type="checkbox"/> | <input type="checkbox"/> | <input type="checkbox"/> | <input type="checkbox"/> | <input type="checkbox"/> | <input type="checkbox"/> | <input type="checkbox"/> | CEILINGS | B | 1 | 2 | 3 | U | PANEL | <input type="checkbox"/> | <input type="checkbox"/> | <input type="checkbox"/> | <input type="checkbox"/> |
| Ventilation | <input type="checkbox"/> Heat Pump | <input type="checkbox"/> | ASPHALT | <input type="checkbox"/> | <input type="checkbox"/> | <input type="checkbox"/> | <input type="checkbox"/> | <input type="checkbox"/> | <input type="checkbox"/> | <input type="checkbox"/> | ACCUT/PANEL | <input type="checkbox"/> | <input type="checkbox"/> | <input type="checkbox"/> | <input type="checkbox"/> | PLASTER / DW | <input type="checkbox"/> | <input type="checkbox"/> | <input type="checkbox"/> | <input type="checkbox"/> | |
| Package Unit | <input type="checkbox"/> Ind TW Heat Pump | <input type="checkbox"/> | GRAVEL | <input type="checkbox"/> | <input type="checkbox"/> | <input type="checkbox"/> | <input type="checkbox"/> | <input type="checkbox"/> | <input type="checkbox"/> | <input type="checkbox"/> | PLASTER/DW | <input type="checkbox"/> | <input type="checkbox"/> | <input type="checkbox"/> | <input type="checkbox"/> | BLOCK | <input type="checkbox"/> | <input type="checkbox"/> | <input type="checkbox"/> | <input type="checkbox"/> | |
| Hot & Cld Water | <input type="checkbox"/> Evaporated Cool | <input type="checkbox"/> | DIRT | <input type="checkbox"/> | <input type="checkbox"/> | <input type="checkbox"/> | <input type="checkbox"/> | <input type="checkbox"/> | <input type="checkbox"/> | <input type="checkbox"/> | SUSP/OPEN | <input type="checkbox"/> | <input type="checkbox"/> | <input type="checkbox"/> | <input type="checkbox"/> | GLAZED TILE | <input type="checkbox"/> | <input type="checkbox"/> | <input type="checkbox"/> | <input type="checkbox"/> | |
| Floor Furnace | <input type="checkbox"/> Co-Ray-Vac | <input type="checkbox"/> | STANDARD | <input type="checkbox"/> | | | | | | | STANDARD | <input type="checkbox"/> | | | | STANDARD | <input type="checkbox"/> | | | | |

| | | | | | | | | | | | | | | | | | | | | | | | | | | |
|-------------------|-----------------------------------|--------------------------|-----------------|--|--|--|--|--------------------------|----------------|--|--|--|----------|--------------------------|-------------|--|--|--|--|--------------------------|--------------|--|--|--|--|-------------------------------------|
| Complete HVAC | <input type="checkbox"/> No Heat | <input type="checkbox"/> | PLUMBING | | | | | A LIGHTING | | | | | A | | | | | | | | | | | | | |
| Refrig. Cooling | <input type="checkbox"/> Standard | <input type="checkbox"/> | NO PLUMBING | | | | | <input type="checkbox"/> | EXTRA FIXTURES | | | | | 4 | FLUORESCENT | | | | | <input type="checkbox"/> | METAL HALIDE | | | | | <input type="checkbox"/> |
| | | | 2 FIXTURE BATH | | | | | 2 | STANDARD | | | | | <input type="checkbox"/> | SODIUM VAP | | | | | <input type="checkbox"/> | STANDARD | | | | | <input checked="" type="checkbox"/> |
| YARD ITEMS | | | 3 FIXTURE BATH | | | | | | | | | | | | MERCURY VAP | | | | | <input type="checkbox"/> | | | | | | |

| ITEM | CONST | HT | SIZE X SIZE | FL | AREA | UNITS | AGE | REM | CND | GRD | \$/UNIT | UNADJUSTED \$ | PHY | FC | EC | MARKET VALUE |
|--------------------------------------|-------|----|-------------|----|--------|-------|-----|-----|-----|-----|---------|---------------|-----|----|----|--------------|
| A 901.002:Paving: Concrete | | | | 1 | 75,000 | | | | N | N | .00 | 0 | 0 | 0 | 0 | 0 |
| B 901.030:Fence: Chainlink Mtl or Vi | | | | 1 | 1,300 | 1300 | | | N | N | .00 | 0 | 0 | 0 | 0 | 0 |
| C 499.054:Porch: Open Frame | | | 6 X 6 | 1 | 36 | | | | A | N | .00 | 0 | 0 | 0 | 0 | 0 |

| ITEM | CONST | HT | SIZE X SIZE | FL | AREA | UNITS | AGE | REM | CND | GRD | \$/UNIT | UNADJUSTED \$ | PHY | FC | EC | MARKET VALUE |
|------------------|-------|----|-------------|----|--------|-------|------|-------|-----|-----|---------|---------------|-----|---------|---------|--------------|
| A 455.000:Garage | S | 16 | | 1 | 12,770 | | 1974 | 1979A | A | F | 32.00 | 408,640 | 33 | 0 | 0 | 273,790 |
| 2 447.000:OFFICE | S | 8 | 35 X 70 | 2 | 2,450 | | 1974 | | A | F | 45.00 | 220,500 | 42 | 50(OTH) | 50(OTH) | 31,980 |

| | | | | | | | | | | | | | | | | |
|----------------------|--|--|--|--|--|--|--|--|--|--|--|--|--|--|-------------------|-----------------|
| AMENITY TOTAL | | | | | | | | | | | | | | | 0 | |
| | | | | | | | | | | | | | | | TOTAL IMPR | *346,660 |

COMMENTS

1/31/2018 TTO: ONLY 40 X 64 COM GAR VACANT. ALL OTHERS ARE BEING USED FOR COMMERCIAL. SMALL AREA IN REAR OF 50 X 253 USED FOR PERSONAL (OWNERS CAMPER, ETC)

Property Address: 715 S SUGAR ST, CELINA

DTE Code: 455



27-010100.0000

JEFFERSON TWP-CELINA CORP
CELINA SD
08-01-476-001

LEGAL INFORMATION

SE SE Acres: 4.7750

RTS: 002-06-01
NOW INVESTMENTS LLC
NOW INVESTMENTS LLC
8744 NOW RD
CELINA, OH 45822

| |
|------------------------|
| Neighborhood CLAK27 |
| Map: Block: |
| Bk: Pg: |

COMMENT
TAX INCENTIVE: TF505

| Sales Data | | | | | | | Date |
|------------|---------|------------|-----------|-------|--------------------------|------------|----------|
| Date | Amount | Deed:Conv# | Use | Valid | Lister: | DL | 04/07/17 |
| 10/09/2020 | 690,000 | | WDC : 746 | 455 | ■ | Pricer: | |
| 07/15/2003 | 400,000 | | : A : 0 | 455 | ■ | Reviewer: | |
| | | | | | <input type="checkbox"/> | Final: | |
| | | | | | <input type="checkbox"/> | Call Back: | |
| | | | | | <input type="checkbox"/> | Visit: | |

| VALUATION SUMMARY | | | | |
|------------------------|-----------------|--|--|--|
| VALUE YEAR | | | | |
| REASON FOR CHANGE | | | | |
| ESTIMATED MARKET VALUE | LAND IMPR TOTAL | | | |
| ASSESSED VALUE | LAND IMPR TOTAL | | | |

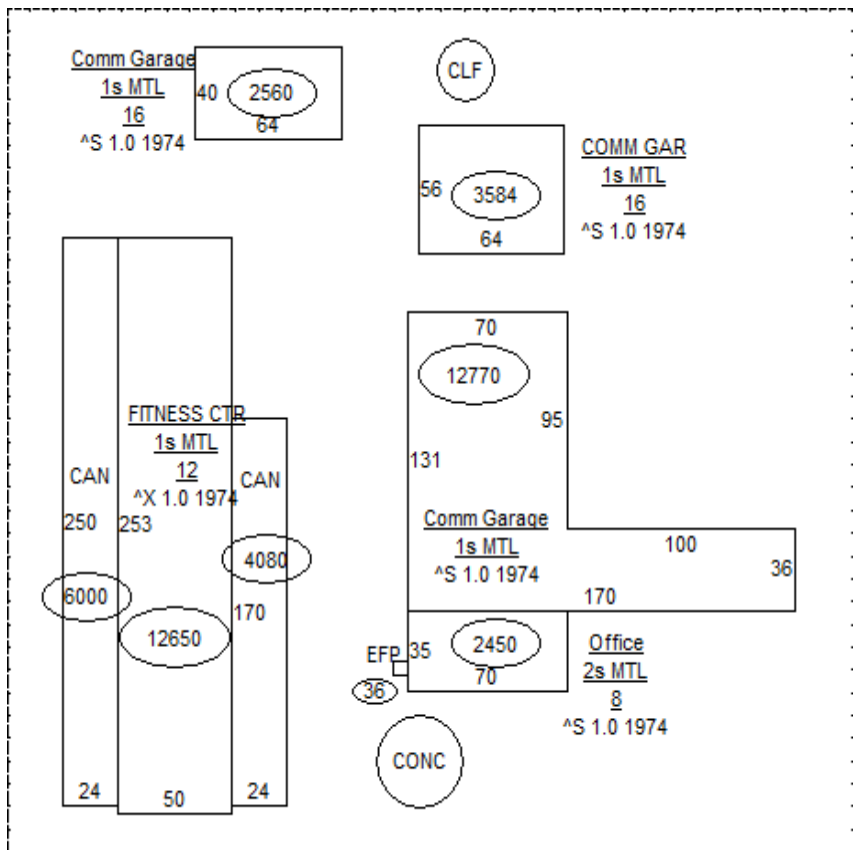

| STREET/ROAD | TOPOGRAPHY | PU-UTILITIES-PR | ZONING |
|---|---|--|--|
| <input checked="" type="checkbox"/> PAVED | <input checked="" type="checkbox"/> LEVEL | <input type="checkbox"/> WATER | <input type="checkbox"/> AG-RES |
| <input type="checkbox"/> GRAVEL | <input type="checkbox"/> HIGH | <input type="checkbox"/> SEWER | <input checked="" type="checkbox"/> COMMERCIAL |
| <input type="checkbox"/> DIRT | <input type="checkbox"/> LOW | <input type="checkbox"/> GAS | <input type="checkbox"/> INDUSTRIAL |
| <input type="checkbox"/> SIDEWALKS | <input type="checkbox"/> ROLLING | <input type="checkbox"/> ELECTRIC | |
| <input type="checkbox"/> CURBS | <input type="checkbox"/> STANDARD | <input checked="" type="checkbox"/> STANDARD | |

| INFLUENCE FACTORS | | |
|-------------------|-------------|----------------|
| A. NO ROAD | E. SZ/SHAPE | I. WATER FRONT |
| B. TOPGRHY | F. RESTRICT | J. OTHER/CDU |
| C. Ex Front | G. WOOD LT | |
| D. QUANTITY | H. VACANCY | |

| LAND TYPE | SIZE | M | RATE | C | INF | M | VALUE | C |
|-----------|--------------------|---|------|---|-----|--------|-------|--------|
| | | | | | | | | |
| | | | | | | | | |
| | | | | | | | | |
| Totals: | Total Acres 4.7750 | | | | | 95,600 | 0 | 95,600 |

Property Address: 715 S SUGAR ST, CELINA

DTE Code: 455



27-010100.0000

JEFFERSON TWP-CELINA CORP
 CELINA SD
 08-01-476-001

LEGAL INFORMATION

SE SE Acres: 4.7750

RTS: 002-06-01
NOW INVESTMENTS LLC
 NOW INVESTMENTS LLC
 8744 NOW RD
 CELINA, OH 45822

| |
|------------------------|
| Neighborhood CLAK27 |
| Map: Block: |
| Bk: Pg: |

COMMENT

| Sales Data | | | | | | | Date |
|------------|---------|------------|-----------|-------|--------------------------|------------|----------|
| Date | Amount | Deed:Conv# | Use | Valid | Lister: | DL | 04/07/17 |
| 10/09/2020 | 690,000 | | WDC : 746 | 455 | ■ | Pricer: | |
| 07/15/2003 | 400,000 | | : A : 0 | 455 | ■ | Reviewer: | |
| | | | | | <input type="checkbox"/> | Final: | |
| | | | | | <input type="checkbox"/> | Call Back: | |
| | | | | | <input type="checkbox"/> | Visit: | |

| VALUATION SUMMARY | | | | |
|------------------------|-----------------|--|--|--|
| VALUE YEAR | | | | |
| REASON FOR CHANGE | | | | |
| ESTIMATED MARKET VALUE | LAND IMPR TOTAL | | | |
| ASSESSED VALUE | LAND IMPR TOTAL | | | |

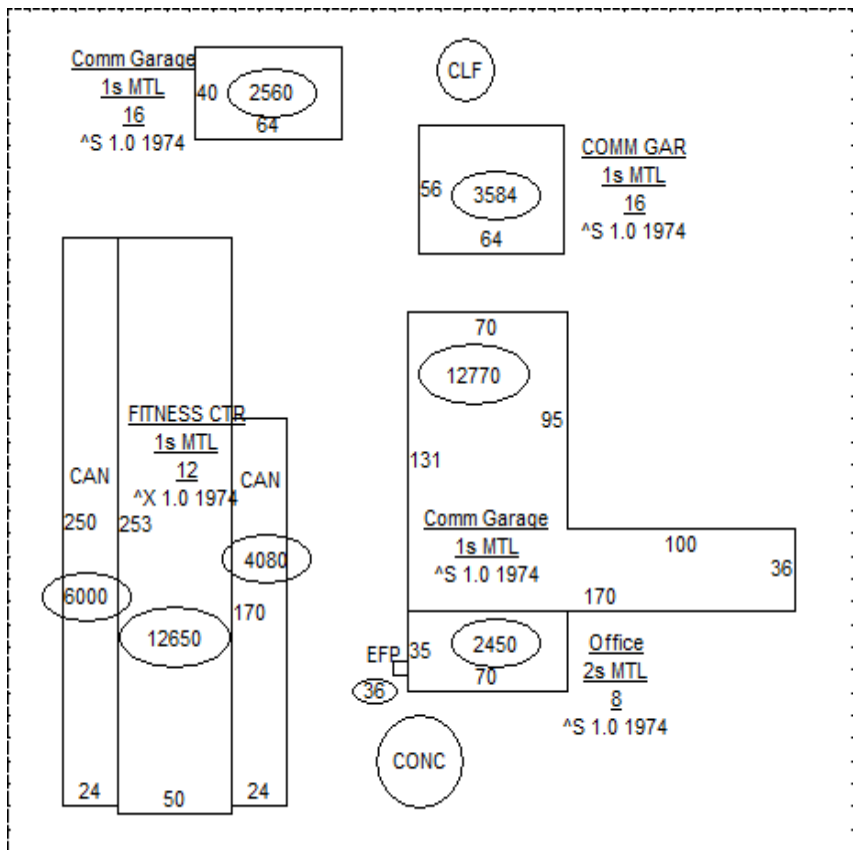

| STREET/ROAD | TOPOGRAPHY | PU-UTILITIES-PR | ZONING |
|---|---|--|--|
| <input checked="" type="checkbox"/> PAVED | <input checked="" type="checkbox"/> LEVEL | <input type="checkbox"/> WATER | <input type="checkbox"/> AG-RES |
| <input type="checkbox"/> GRAVEL | <input type="checkbox"/> HIGH | <input type="checkbox"/> SEWER | <input checked="" type="checkbox"/> COMMERCIAL |
| <input type="checkbox"/> DIRT | <input type="checkbox"/> LOW | <input type="checkbox"/> GAS | <input type="checkbox"/> INDUSTRIAL |
| <input type="checkbox"/> SIDEWALKS | <input type="checkbox"/> ROLLING | <input type="checkbox"/> ELECTRIC | |
| <input type="checkbox"/> CURBS | <input type="checkbox"/> STANDARD | <input checked="" type="checkbox"/> STANDARD | |

| INFLUENCE FACTORS | | |
|-------------------|-------------|----------------|
| A. NO ROAD | E. SZ/SHAPE | I. WATER FRONT |
| B. TOPGRHY | F. RESTRICT | J. OTHER/CDU |
| C. Ex Front | G. WOOD LT | |
| D. QUANTITY | H. VACANCY | |

| LAND TYPE | SIZE | M | RATE | C | INF | M | VALUE | C |
|-----------|--------------------|---|------|---|-----|--------|-------|--------|
| | | | | | | | | |
| | | | | | | | | |
| | | | | | | | | |
| Totals: | Total Acres 4.7750 | | | | | 95,600 | 0 | 95,600 |

Property Address: 715 S SUGAR ST, CELINA

DTE Code: 455



27-010100.0000

JEFFERSON TWP-CELINA CORP
 CELINA SD
 08-01-476-001

LEGAL INFORMATION

SE SE Acres: 4.7750

RTS: 002-06-01

NOW INVESTMENTS LLC
 NOW INVESTMENTS LLC
 8744 NOW RD
 CELINA, OH 45822

COMMENT

| |
|------------------------|
| Neighborhood CLAK27 |
| Map: Block: |
| Bk: Pg: |

| Sales Data | | | | | | | Date |
|------------|---------|------------|-----------|-------|--------------------------|------------|----------|
| Date | Amount | Deed:Conv# | Use | Valid | Lister: | DL | 04/07/17 |
| 10/09/2020 | 690,000 | | WDC : 746 | 455 | ■ | Pricer: | |
| 07/15/2003 | 400,000 | | : A : 0 | 455 | ■ | Reviewer: | |
| | | | | | <input type="checkbox"/> | Final: | |
| | | | | | <input type="checkbox"/> | Call Back: | |
| | | | | | <input type="checkbox"/> | Visit: | |

| VALUATION SUMMARY | | | | |
|------------------------|-----------------|--|--|--|
| VALUE YEAR | | | | |
| REASON FOR CHANGE | | | | |
| ESTIMATED MARKET VALUE | LAND IMPR TOTAL | | | |
| ASSESSED VALUE | LAND IMPR TOTAL | | | |

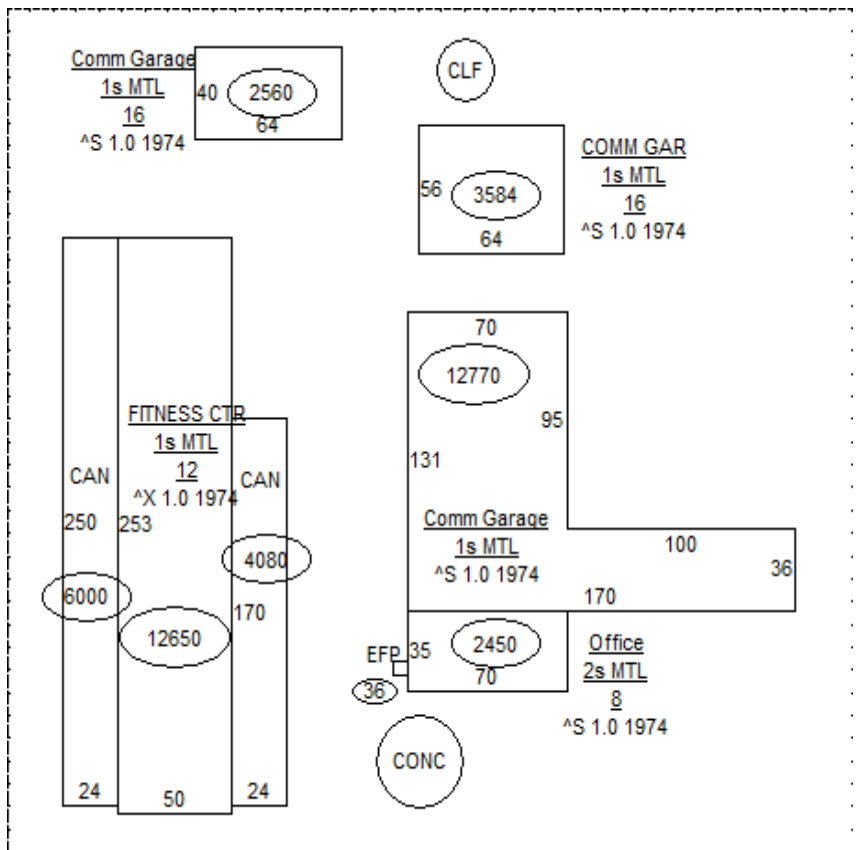

| STREET/ROAD | TOPOGRAPHY | PU-UTILITIES-PR | ZONING |
|---|---|--|--|
| <input checked="" type="checkbox"/> PAVED | <input checked="" type="checkbox"/> LEVEL | <input type="checkbox"/> WATER | <input type="checkbox"/> AG-RES |
| <input type="checkbox"/> GRAVEL | <input type="checkbox"/> HIGH | <input type="checkbox"/> SEWER | <input checked="" type="checkbox"/> COMMERCIAL |
| <input type="checkbox"/> DIRT | <input type="checkbox"/> LOW | <input type="checkbox"/> GAS | <input type="checkbox"/> INDUSTRIAL |
| <input type="checkbox"/> SIDEWALKS | <input type="checkbox"/> ROLLING | <input type="checkbox"/> ELECTRIC | |
| <input type="checkbox"/> CURBS | <input type="checkbox"/> STANDARD | <input checked="" type="checkbox"/> STANDARD | |

| INFLUENCE FACTORS | | |
|-------------------|-------------|----------------|
| A. NO ROAD | E. SZ/SHAPE | I. WATER FRONT |
| B. TOPGRHY | F. RESTRICT | J. OTHER/CDU |
| C. Ex Front | G. WOOD LT | |
| D. QUANTITY | H. VACANCY | |

| LAND TYPE | SIZE | M | RATE | C | INF | M | VALUE | C |
|-----------|--------------------|---|------|---|-----|--------|-------|--------|
| | | | | | | | | |
| | | | | | | | | |
| | | | | | | | | |
| Totals: | Total Acres 4.7750 | | | | | 95,600 | 0 | 95,600 |

