



27-007050.0000

JEFFERSON TWP-CELINA CORP
 CELINA SD
 08-01-301-002

LEGAL INFORMATION

NW SW

Acres:2.0000

RTS: 002-06-01
RTJ FARMS LLC
 RTJ FARMS LLC
 204 SCENIC RIDGE
 ONTARIO, OH 44903

Neighborhood CSTR20
Map:
Block:
Card:
Bk: Pg:

COMMENT
 TY2022:Net Gen=\$3,645.14, Other Assessment=\$0.00
 DE17 DESKTOP RVW CHGS: ADJ PRICING
 Address to be changes to 500 Meyer Rd. When property conveys to a new owner.

Sales Data							Date
Date	Amount	Deed:Conv#	Use	Valid	Lister:	DL	04/07/17
03/02/2023	220,000		WDC : 104	480	■	Pricer:	
02/22/1994	220,000		: A : 0	480	■	Reviewer:	
					<input type="checkbox"/>	Final:	
					<input type="checkbox"/>	Call Back:	
					<input type="checkbox"/>	Visit:	

VALUATION SUMMARY				
VALUE YEAR	2023	2020	2017	2017
REASON FOR CHANGE	RAPP	RAPP	RAPP	MISC
ESTIMATED	36,400	27,140	27,140	26,680
MARKET VALUE	IMPR	275,640	166,200	172,050
	TOTAL	312,040	193,340	199,190
ASSESSED	LAND	12,740	9,500	9,500
VALUE	IMPR	96,470	58,170	60,220
	TOTAL	109,210	67,670	69,720
				70,490

LAND TYPE	SIZE	M	RATE	C	INF	M	VALUE	C
1:Primary	A:2		28,000				36,400	0
Totals:	Total Acres 2.0000						36,400	0

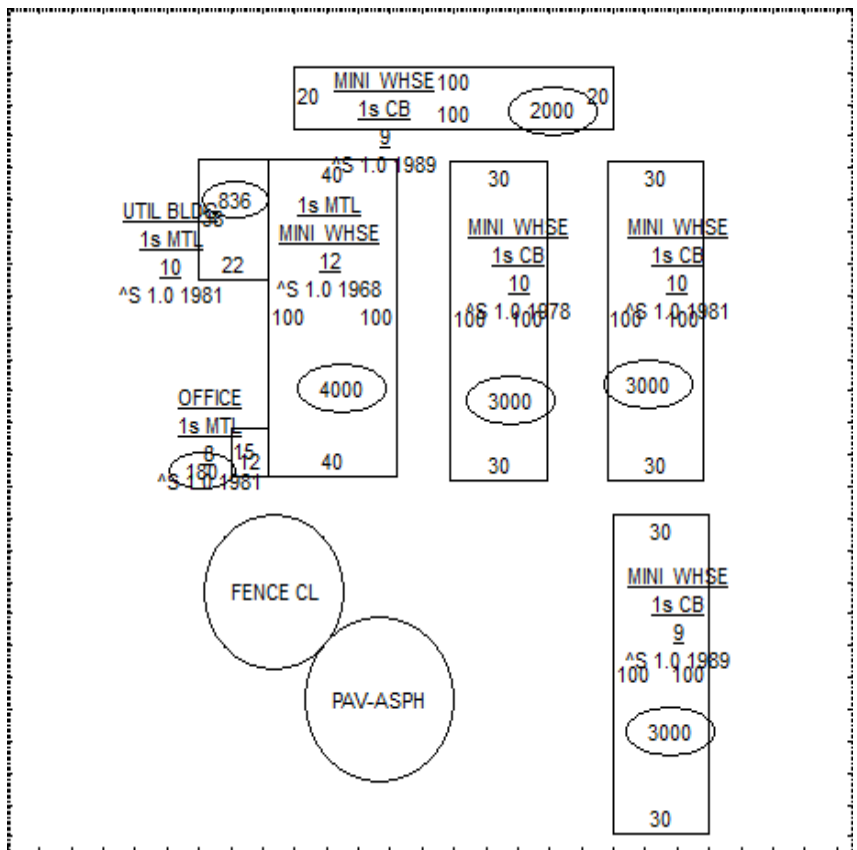

STREET/ROAD	TOPOGRAPHY	PU-UTILITIES-PR	ZONING
<input checked="" type="checkbox"/> PAVED	<input checked="" type="checkbox"/> LEVEL	<input type="checkbox"/> WATER	<input type="checkbox"/> AG-RES
<input type="checkbox"/> GRAVEL	<input type="checkbox"/> HIGH	<input type="checkbox"/> SEWER	<input checked="" type="checkbox"/> COMMERCIAL
<input type="checkbox"/> DIRT	<input type="checkbox"/> LOW	<input type="checkbox"/> GAS	<input type="checkbox"/> INDUSTRIAL
<input type="checkbox"/> SIDEWALKS	<input type="checkbox"/> ROLLING	<input type="checkbox"/> ELECTRIC	
<input type="checkbox"/> CURBS	<input type="checkbox"/> STANDARD	<input checked="" type="checkbox"/> STANDARD	

INFLUENCE FACTORS		
A. NO ROAD	E. SZ/SHAPE	I. WATER FRONT
B. TOPGRHY	F. RESTRICT	J. OTHER/CDU
C. Ex Front	G. WOOD LT	
D. QUANTITY	H. VACANCY	

		EX WALL	A	ROOFING	A	WINDOW	A	DOORS	A	FOUNDATION	A	FRAMING	A
		STONE	<input type="checkbox"/>	GABLE/HIP	<input type="checkbox"/>	STORE FRT	<input type="checkbox"/>	OVERHEAD	<input type="checkbox"/>	SLAB	<input checked="" type="checkbox"/>	PRE ENG	<input type="checkbox"/>
CLASS/QUALITY RANK		BRICK	<input type="checkbox"/>	SHED/FLAT	<input type="checkbox"/>	CASEMENT	<input type="checkbox"/>			CRAWL	<input type="checkbox"/>	STEEL	<input checked="" type="checkbox"/>
A) FP STRUCT. STEEL FRAME	1. BASIC	CON BLK	<input type="checkbox"/>	CON DECK	<input type="checkbox"/>	DBLH	<input type="checkbox"/>			PILE/COL	<input type="checkbox"/>	REINF CONC	<input type="checkbox"/>
B) R.C. FRAME	2. FAIR	WD/MTL	<input type="checkbox"/>	MTL DECK	<input type="checkbox"/>	SLIDE BY	<input type="checkbox"/>			REINFOR	<input type="checkbox"/>	CB/MASON	<input type="checkbox"/>
C) MASONRY BEARING WALLS	3. AVE	ENAM STL	<input checked="" type="checkbox"/>	WD DECK	<input type="checkbox"/>	CANOPY	A			STEEL	<input type="checkbox"/>	FRAME	<input type="checkbox"/>
D) WD OR STEEL FR EX. WALLS	4. GOOD	ALUM/VYL	<input type="checkbox"/>	METAL	<input checked="" type="checkbox"/>	LIGHTED	<input type="checkbox"/>	STEEL INS	<input type="checkbox"/>	BRICK	<input type="checkbox"/>	POLE	<input type="checkbox"/>
S) METAL M) MILL P) POLE	5. EXCEL	CON PANEL	<input type="checkbox"/>	ASPH	<input type="checkbox"/>	SOFFITS	<input type="checkbox"/>	WOOD	<input type="checkbox"/>	STONE	<input type="checkbox"/>	TILT UP	<input type="checkbox"/>
TOTAL AREA	PERIMETER 280	PLATE GLS	<input type="checkbox"/>	RUBBER	<input type="checkbox"/>	C S W	<input type="checkbox"/>	MTL	<input type="checkbox"/>	CON BLK	<input type="checkbox"/>	SANDWICH	<input type="checkbox"/>
# STORIES 1	STORY HT 12	STUCCO	<input type="checkbox"/>	BUILT UP	<input type="checkbox"/>	FACADE	A	GLASS	<input type="checkbox"/>	FRAME	<input type="checkbox"/>	STANDARD	<input type="checkbox"/>
AGE	SPRINKLER	INSULATED	<input type="checkbox"/>	INSULATED	<input type="checkbox"/>			STANDARD	<input type="checkbox"/>	STANDARD	<input type="checkbox"/>		

H.V.A.C.		FLOORS				PARTITIONS					INTERIOR FINISH										
Electric	<input type="checkbox"/>	Electric Wall	<input type="checkbox"/>	CONCRETE	<input type="checkbox"/>	<input checked="" type="checkbox"/>	<input type="checkbox"/>	<input type="checkbox"/>	<input type="checkbox"/>	<input type="checkbox"/>	MASONRY	<input type="checkbox"/>	<input type="checkbox"/>	<input type="checkbox"/>	<input type="checkbox"/>	UNFINISHED	<input type="checkbox"/>	<input type="checkbox"/>	<input type="checkbox"/>	<input type="checkbox"/>	<input type="checkbox"/>
Forced Air Unit	<input type="checkbox"/>	Hot Water	<input type="checkbox"/>	WOOD	<input type="checkbox"/>	<input type="checkbox"/>	<input type="checkbox"/>	<input type="checkbox"/>	<input type="checkbox"/>	WD STUD	<input type="checkbox"/>	<input type="checkbox"/>	<input type="checkbox"/>	<input type="checkbox"/>	<input type="checkbox"/>	FINISH OPEN	<input type="checkbox"/>	<input type="checkbox"/>	<input type="checkbox"/>	<input type="checkbox"/>	<input type="checkbox"/>
Hot Water, Rad	<input type="checkbox"/>	Space/ Wall Furnace	<input type="checkbox"/>	TILE A Q V T	<input type="checkbox"/>	<input type="checkbox"/>	<input type="checkbox"/>	<input type="checkbox"/>	<input type="checkbox"/>	MTL STUD	<input type="checkbox"/>	<input type="checkbox"/>	<input type="checkbox"/>	<input type="checkbox"/>	<input type="checkbox"/>	FINISH DIV	<input type="checkbox"/>	<input checked="" type="checkbox"/>	<input type="checkbox"/>	<input type="checkbox"/>	<input type="checkbox"/>
Steam	<input type="checkbox"/>	Warm & Cld Air	<input checked="" type="checkbox"/>	CARPET	<input type="checkbox"/>	<input type="checkbox"/>	<input type="checkbox"/>	<input type="checkbox"/>	<input type="checkbox"/>	CEILINGS	B	1	2	3	U	PANEL	<input type="checkbox"/>	<input type="checkbox"/>	<input type="checkbox"/>	<input type="checkbox"/>	<input type="checkbox"/>
Ventilation	<input type="checkbox"/>	Heat Pump	<input type="checkbox"/>	ASPHALT	<input type="checkbox"/>	<input type="checkbox"/>	<input type="checkbox"/>	<input type="checkbox"/>	<input type="checkbox"/>	ACCUT/PANEL	<input type="checkbox"/>	<input type="checkbox"/>	<input type="checkbox"/>	<input type="checkbox"/>	<input type="checkbox"/>	PLASTER / DW	<input type="checkbox"/>	<input type="checkbox"/>	<input type="checkbox"/>	<input type="checkbox"/>	<input type="checkbox"/>
Package Unit	<input type="checkbox"/>	Ind TW Heat Pump	<input type="checkbox"/>	GRAVEL	<input type="checkbox"/>	<input type="checkbox"/>	<input type="checkbox"/>	<input type="checkbox"/>	<input type="checkbox"/>	PLASTER/DW	<input type="checkbox"/>	<input type="checkbox"/>	<input type="checkbox"/>	<input type="checkbox"/>	<input type="checkbox"/>	BLOCK	<input type="checkbox"/>	<input type="checkbox"/>	<input type="checkbox"/>	<input type="checkbox"/>	<input type="checkbox"/>
Hot & Cld Water	<input type="checkbox"/>	Evaporated Cool	<input type="checkbox"/>	DIRT	<input type="checkbox"/>	<input type="checkbox"/>	<input type="checkbox"/>	<input type="checkbox"/>	<input type="checkbox"/>	SUSP/OPEN	<input type="checkbox"/>	<input type="checkbox"/>	<input type="checkbox"/>	<input type="checkbox"/>	<input type="checkbox"/>	GLAZED TILE	<input type="checkbox"/>	<input type="checkbox"/>	<input type="checkbox"/>	<input type="checkbox"/>	<input type="checkbox"/>
Floor Furnace	<input type="checkbox"/>	Co-Ray-Vac	<input type="checkbox"/>	STANDARD	<input type="checkbox"/>					STANDARD	<input type="checkbox"/>					STANDARD	<input type="checkbox"/>				

Complete HVAC	<input type="checkbox"/>	No Heat	<input type="checkbox"/>	PLUMBING					A	LIGHTING					A			
Refrig. Cooling	<input type="checkbox"/>	Standard	<input type="checkbox"/>	NO PLUMBING				<input type="checkbox"/>	EXTRA FIXTURES			FLUORESCENT			<input type="checkbox"/>	METAL HALIDE		<input type="checkbox"/>
				2 FIXTURE BATH				2	STANDARD		<input type="checkbox"/>	SODIUM VAP			<input type="checkbox"/>	STANDARD		<input checked="" type="checkbox"/>
				3 FIXTURE BATH								MERCURY VAP			<input type="checkbox"/>			

YARD ITEMS		CONST	HT	SIZE X SIZE	FL	AREA	UNITS	AGE	REM	CND	GRD	\$/UNIT	UNADJUSTED \$	PHY	FC	EC	MARKET VALUE
A	901.001:Paving: Asphalt				1	8,200		1982		N	N	.00	0	0	0	0	0
B	901.030:Fence: Chainlink Mtl or Vi				1	920	920	1968		N	N	.00	0	0	0	0	0

YARD ITEMS		CONST	HT	SIZE X SIZE	FL	AREA	UNITS	AGE	REM	CND	GRD	\$/UNIT	UNADJUSTED \$	PHY	FC	EC	MARKET VALUE
A	480.003:MINI WHSE		12	100 X 40	1	4,000		1968		F	A	27.00	108,000	45	0	0	59,400
1	447.000:OFFICE		8	15 X 12	1	180		1981		A	B	36.00	6,480	38	0	0	4,020
2	499.078:UTIL BLDG		10	38 X 22	1	836		1981		F	F	12.80	10,700	42	0	0	6,210
3	480.003:MINI WHSE		10	100 X 30	1	3,000		1978		F	A	27.00	81,000	35	0	0	52,650
4	480.003:MINI WHSE		10	100 X 30	1	3,000		1981		A	A	27.00	81,000	32	0	0	55,080
5	480.003:MINI WHSE		9	20 X 100	1	2,000		1989		A	A	27.00	54,000	26	0	0	39,960
6	480.003:MINI WHSE		9	100 X 30	1	3,000		1989		F	A	27.00	81,000	28	0	0	58,320

AMENITY TOTAL																0	
																TOTAL IMPR	275,640

COMMENTS