

JEFFERSON TWP-CELINA CORP / CELINA SD

05-36-152-002

27-002600.0132

SULLIVAN DARRYL R & ARLEEN A

SULLIVAN DARRYL R & ARLEEN A
 1236 JESSICA LN
 CELINA, OH 45822

LEGAL INFORMATION

WHEATLAND ACRES SUBD
 SEC 1
 LOT#: 31

	OWNERSHIP	ADDRESS	CITY	STATE	ZIP	DATE	AMOUNT	DEED:CONV#	JS	VALID
1	SULLIVAN DARRYL R &	1236 JESSICA LN	CELINA	OH	45822	06/26/2020	355,000	WDC : 402	<input type="checkbox"/>	<input checked="" type="checkbox"/>
2	HOENIE MARK D & JUDITH A	1236 JESSCIA LN	CELINA	OH	45822	05/01/2018	325,000	WDC : 277	<input type="checkbox"/>	<input checked="" type="checkbox"/>
3	SHELLABARGER CURT &	1236 JESSICA LN	CELINA	OH	45822	12/09/1997	27,300	: A : 0	<input type="checkbox"/>	<input type="checkbox"/>

X: TTO LISTER: MV DATE: 06/25/2019 TIME: 12:00:00 AM LETTER LETTER REC'D GIS CODE

STREET/ROAD	TOPOGRAPHY	PU-UTILITIES-PR	NEIGHBORHOOD	INFLUENCE FACTORS				PROPERTY LOCATION
<input checked="" type="checkbox"/> PAVED <input type="checkbox"/> GRAVEL <input type="checkbox"/> DIRT <input type="checkbox"/> SIDEWALKS <input type="checkbox"/> CURBS	<input checked="" type="checkbox"/> LEVEL <input type="checkbox"/> HIGH <input type="checkbox"/> LOW <input type="checkbox"/> ROLLING <input type="checkbox"/> STANDARD	<input type="checkbox"/> WATER <input type="checkbox"/> SEWER <input type="checkbox"/> GAS <input type="checkbox"/> ELECTRIC <input checked="" type="checkbox"/> STANDARD	<input type="checkbox"/> IMPROVING <input type="checkbox"/> STATIC <input type="checkbox"/> DECLINING <input type="checkbox"/> OLD <input type="checkbox"/> STANDARD	<input type="checkbox"/> A. NO ROAD <input type="checkbox"/> B. TOPGRHY <input type="checkbox"/> C. Ex Front <input type="checkbox"/> D. QUANTITY <input type="checkbox"/> E. SZ/SHAPE	<input type="checkbox"/> F. RESTRICT <input type="checkbox"/> G. WOOD LT <input type="checkbox"/> H. VACANCY <input type="checkbox"/> I. WATER FRONT <input type="checkbox"/> J. OTHER/CDU	1236 JESSICA LN, CELINA		

COMMENT
 TY2022:Net Gen=\$4,461.76, Other
 Assessment=\$0.00
 DE19 5/27/2019 TORNADO DAMAGED ROOF,
 SIDING, 2 WINDOWS, GARAGE DOOR &
 SPOUTING
 DE20 REPAIRS COMPL; COR PAT
 MSMNTS//UPDATED PLUMB
 DE19 RMV OWN OCC; DIDN'T RET APP

LAND COMPUTATIONS							
LAND TYPE	SIZE	M	RATE	C	INF	M	VALUE C
F:Front	F107 D127	ST500	DP92	ADJ460		49,200	0
					TOTAL	49,200	0

VALUATION SUMMARY							
VALUE YEAR	2023	2020	2020	2020	2019	2017	
REASON FOR CHANGE	RAPP	RAPP	MISC	NC	REMB	RAPP	
APPRAISED	LAND	49,200	33,000	27,600	27,600	27,600	
VALUE	IMPR	324,100	243,100	240,100	237,900	212,900	
	TOTAL	373,300	276,100	267,700	265,500	240,500	
ASSESSED	LAND	17,220	11,550	9,660	9,660	9,660	
VALUE	IMPR	113,440	85,090	84,040	83,270	74,520	
	TOTAL	130,660	96,640	93,700	92,930	84,180	

OCCUPANCY		EXTERIOR		FLOOR	AREA	CONST	VALUE
<input checked="" type="checkbox"/> SF <input type="checkbox"/> DU <input type="checkbox"/> TR <input type="checkbox"/> CONVERSION BUILDING TYPE <input type="checkbox"/> MOBILE HOME <input type="checkbox"/> BI/TR LEVEL <input type="checkbox"/> MOD/MAN <input type="checkbox"/> _____		<input checked="" type="checkbox"/> WOOD <input type="checkbox"/> STUCCO <input type="checkbox"/> ALM/VYNL <input type="checkbox"/> CONC BLK <input type="checkbox"/> METAL <input checked="" type="checkbox"/> BRICK <input type="checkbox"/> STONE		1	2298	FR	256,890
ROOFING		ROOF TYPE					
<input type="checkbox"/> METAL <input type="checkbox"/> SLT/TLE <input checked="" type="checkbox"/> SHINGLES <input type="checkbox"/> SHAKES <input type="checkbox"/> COMPOSITE		<input checked="" type="checkbox"/> GABLE <input type="checkbox"/> HIP <input type="checkbox"/> GAMBREL <input type="checkbox"/> MANSARD <input type="checkbox"/> FLAT					
FLOORS		B	1	2	3	U	
CONCRETE		<input checked="" type="checkbox"/>	<input type="checkbox"/>	<input type="checkbox"/>	<input type="checkbox"/>	<input type="checkbox"/>	
WOOD		<input type="checkbox"/>	<input type="checkbox"/>	<input type="checkbox"/>	<input type="checkbox"/>	<input type="checkbox"/>	
TILE/COMPO		<input type="checkbox"/>	<input checked="" type="checkbox"/>	<input type="checkbox"/>	<input type="checkbox"/>	<input type="checkbox"/>	
CARPET		<input type="checkbox"/>	<input checked="" type="checkbox"/>	<input type="checkbox"/>	<input type="checkbox"/>	<input type="checkbox"/>	
INT. FINISH		B	1	2	3	U	
PLASTER/DW		<input type="checkbox"/>	<input checked="" type="checkbox"/>	<input type="checkbox"/>	<input type="checkbox"/>	<input type="checkbox"/>	
PANELING		<input type="checkbox"/>	<input type="checkbox"/>	<input type="checkbox"/>	<input type="checkbox"/>	<input type="checkbox"/>	
UNFINISHED		<input type="checkbox"/>	<input type="checkbox"/>	<input type="checkbox"/>	<input type="checkbox"/>	<input type="checkbox"/>	
ACCOMMODATIONS							
# OF ROOMS		1	6				
BEDROOMS			3				
FIREPLACES		2					
HEAT & AC	B	1	2	3	U		
NO HEAT	<input type="checkbox"/>	<input type="checkbox"/>	<input type="checkbox"/>	<input type="checkbox"/>	<input type="checkbox"/>		
CTRL HEAT	<input checked="" type="checkbox"/>	<input checked="" type="checkbox"/>	<input type="checkbox"/>	<input type="checkbox"/>	<input type="checkbox"/>		
HW/STEAM	<input type="checkbox"/>	<input type="checkbox"/>	<input type="checkbox"/>	<input type="checkbox"/>	<input type="checkbox"/>		
ELECTRIC	<input type="checkbox"/>	<input type="checkbox"/>	<input type="checkbox"/>	<input type="checkbox"/>	<input type="checkbox"/>		
HEAT PUMP	<input type="checkbox"/>	<input type="checkbox"/>	<input type="checkbox"/>	<input type="checkbox"/>	<input type="checkbox"/>		
FLR/WALL	<input type="checkbox"/>	<input type="checkbox"/>	<input type="checkbox"/>	<input type="checkbox"/>	<input type="checkbox"/>		
STVE/SPCE	<input type="checkbox"/>	<input type="checkbox"/>	<input type="checkbox"/>	<input type="checkbox"/>	<input type="checkbox"/>		
GEOHERMAL	<input type="checkbox"/>	<input type="checkbox"/>	<input type="checkbox"/>	<input type="checkbox"/>	<input type="checkbox"/>		
OUTSIDE	<input type="checkbox"/>	<input type="checkbox"/>	<input type="checkbox"/>	<input type="checkbox"/>	<input type="checkbox"/>		
CTRL A/C	<input checked="" type="checkbox"/>	<input checked="" type="checkbox"/>	<input type="checkbox"/>	<input type="checkbox"/>	<input type="checkbox"/>		
PLUMBING		BASE <input checked="" type="checkbox"/>					
X FULL BATH		1					
X HALF BATH		1					
X FIXTURES		2					
BSMT			2298				32,860
SUBTOTAL							289,750
MULTI-FAMILY #		0					0
BUILDING TYPE		100%					0
BSMT FINISH		1,724 S.F.					24,650
FIREPLACE #		2					8,800
HEATING		0 S.F.					0
AIR COND		4,022 S.F.					6,630
PLUMBING #		7					8,470
GARAGES & CARPORTS							20,800
EXTRA FEATURES							7,100
SUBTOTAL							366,200
GRADE FACTOR							115 %
UNADJUSTED VALUE							421,130
FACTOR							100 %

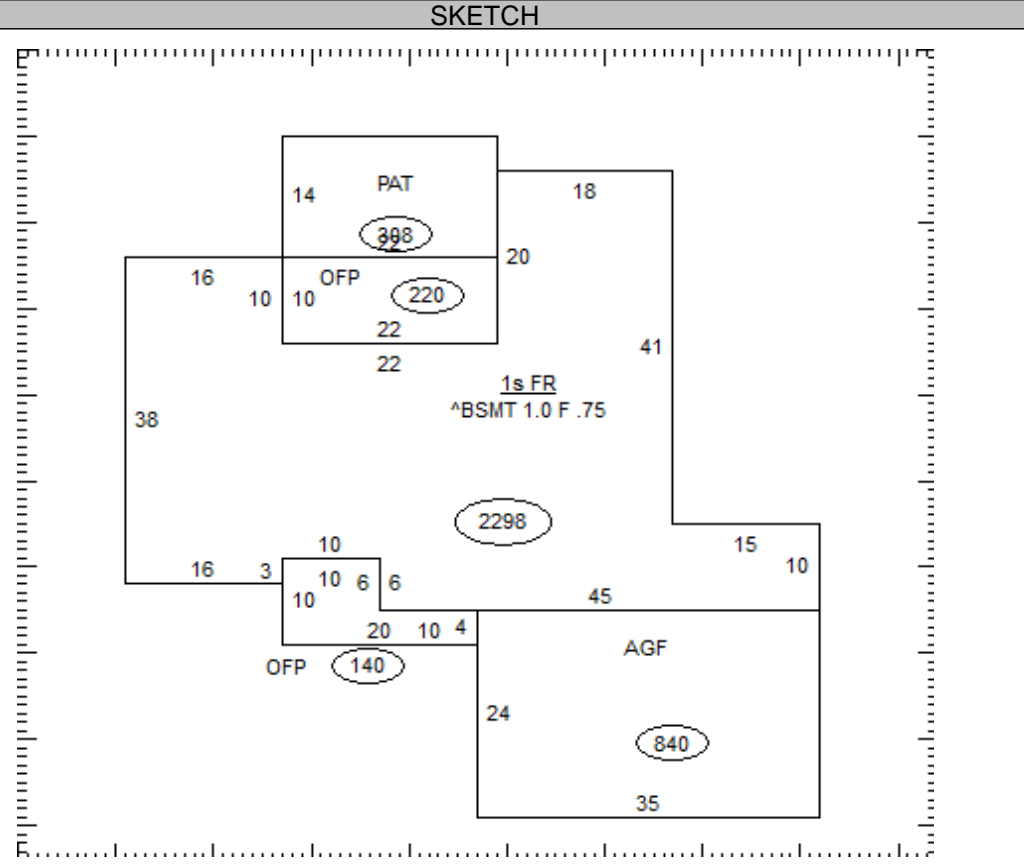

OCCUPANCY	ST.HT	SIZE	AREA	GRADE	PRICE	AGE	REMD	CND	UNADJ VAL	PHYS	PHYS VAL	FUNC	TRUE VAL
DWELLING	1	SK	2,298	B-		1998		A	421,130	19	341,120		324,100
1													
2													
3													
4													
5													
6													
7													
8													
9													
10													
11													

27-002600.0132

TOTAL 324,100

COMMENTS

110 L/F BRICK TRIM 8' HIGH
 Dwelling has an Economic Factor of 95%