

26-144800.0000

**WALLEY CHRISTOPHER B & CAREY L**

WALLEY CHRISTOPHER B & CAREY L  
6674 LAKE ACRES DR  
CELINA, OH 45822

**LEGAL INFORMATION**

LAKE ACRES SUBDIVISION #1  
ALSO PT VAC RIGHT OF WAY  
LOT#: 23

	OWNERSHIP	ADDRESS	CITY	STATE	ZIP	DATE	AMOUNT	DEED:CONV#	JS	VALID
1	WALLEY CHRISTOPHER B &	6674 LAKE ACRES DR	CELINA	OH	45822	06/19/2020	375,000	WDC : 377	<input type="checkbox"/>	<input checked="" type="checkbox"/>
2	MANSON SANDRA L	6674 LAKE ACRES DR	CELINA	OH	45822	01/03/2017	195,500	WDC : 1	<input type="checkbox"/>	<input checked="" type="checkbox"/>
3	FISHBAUGH ALVERA B	10 CATTAIL CIR	GREEN SPRINGS	OH	44836	09/05/2014	0	2:QCE : X : 0	<input type="checkbox"/>	<input type="checkbox"/>

X:	<input type="checkbox"/> TTO	LISTER: HK	DATE: 03/21/2022	TIME: 12:00:00 AM	<input checked="" type="checkbox"/> LETTER	<input type="checkbox"/> LETTER REC'D	GIS CODE
----	------------------------------	------------	------------------	-------------------	--	---------------------------------------	----------

STREET/ROAD	TOPOGRAPHY	PU-UTILITIES-PR	NEIGHBORHOOD	INFLUENCE FACTORS	PROPERTY LOCATION
<input checked="" type="checkbox"/> PAVED	<input checked="" type="checkbox"/> LEVEL	<input type="checkbox"/> WATER	<input checked="" type="checkbox"/> IMPROVING	<input type="checkbox"/> A. NO ROAD	6674 LAKE ACRES DR, CELINA
<input type="checkbox"/> GRAVEL	<input type="checkbox"/> HIGH	<input type="checkbox"/> SEWER	<input checked="" type="checkbox"/> STATIC	<input type="checkbox"/> F. RESTRICT	<b>COMMENT</b> TY2022:Net Gen=\$9,812.76, Other Assessment=\$457.36 DE18 NOH:ADD INGRND POOL, PAT, COR SKETCH DE17 CORR SKETCH/DSKTP REV WATERFRONT DE18 RMV OWN OCC. Didn't ret app DE20 RMV FNC FOR "RESTRICTIONS" ON LAND DE21 RMV HOMESTEAD CREDIT DE22 DWLG ADDTN, ADD RMDL YR, CHG COND TO GOOD DE22 ADD 2 FULL BATHS/FP; PER MAILER BOR: BOR 22-04 (Mod SM:)705
<input type="checkbox"/> DIRT	<input type="checkbox"/> LOW	<input checked="" type="checkbox"/> GAS	<input type="checkbox"/> DECLINING	<input type="checkbox"/> B. TOPGRHY	
<input type="checkbox"/> SIDEWALKS	<input type="checkbox"/> ROLLING	<input checked="" type="checkbox"/> ELECTRIC	<input type="checkbox"/> OLD	<input type="checkbox"/> C. Ex Front	
<input type="checkbox"/> CURBS	<input type="checkbox"/> STANDARD	<input type="checkbox"/> STANDARD	<input type="checkbox"/> STANDARD	<input type="checkbox"/> D. QUANTITY	
				<input type="checkbox"/> E. SZ/SHAPE	
				<input checked="" type="checkbox"/> J. OTHER/CDU	

LAND COMPUTATIONS							
LAND TYPE	SIZE	M	RATE	C	INF	M	VALUE C
F:Front	F201 D202	ST1500 DP113 ADJ1695	5:0.48			177,200	0
TOTAL						177,200	0

VALUATION SUMMARY								
VALUE YEAR	2023	2023	2023	2022	2022	2020	2020	2020
REASON FOR CHANGE	MISC	RAPP	BOR	NC	NC	RAPP	MISC	MISC
APPRAISED	LAND	177,200	186,600	176,300	293,900	293,900	293,900	245,700
VALUE	IMPR	373,200	373,200	320,100	320,100	204,900	176,400	176,400
	TOTAL	550,400	559,800	496,400	614,000	498,800	446,000	422,100
ASSESSED	LAND	62,020	65,310	61,710	102,870	102,870	94,360	86,000
VALUE	IMPR	130,620	130,620	112,040	112,040	71,720	61,740	61,740
	TOTAL	192,640	195,930	173,750	214,910	174,590	156,100	147,740

OCCUPANCY	EXTERIOR	FLOOR	AREA	CONST	VALUE
<input checked="" type="checkbox"/> SF <input type="checkbox"/> DU <input type="checkbox"/> TR	<input type="checkbox"/> WOOD	1	2584	FR	278,610
<input type="checkbox"/> CONVERSION	<input type="checkbox"/> STUCCO				
<b>BUILDING TYPE</b>	<input checked="" type="checkbox"/> ALM/VYNL				
<input type="checkbox"/> MOBILE HOME	<input type="checkbox"/> CONC BLK				
<input type="checkbox"/> BI/TR LEVEL	<input type="checkbox"/> METAL				
<input type="checkbox"/> MOD/MAN	<input type="checkbox"/> BRICK				
<input type="checkbox"/> _____	<input type="checkbox"/> STONE				

ROOFING	ROOF TYPE				
<input type="checkbox"/> METAL	<input checked="" type="checkbox"/> GABLE				
<input type="checkbox"/> SLT/TLE	<input type="checkbox"/> HIP				
<input checked="" type="checkbox"/> SHINGLES	<input type="checkbox"/> GAMBREL				
<input type="checkbox"/> SHAKES	<input type="checkbox"/> MANSARD				
<input type="checkbox"/> COMPOSITE	<input type="checkbox"/> FLAT				

FLOORS	B	1	2	3	U			
CONCRETE	<input checked="" type="checkbox"/>	<input type="checkbox"/>	<input type="checkbox"/>	<input type="checkbox"/>	<input type="checkbox"/>	BSMT	1720	24,600
WOOD	<input type="checkbox"/>	<input type="checkbox"/>	<input type="checkbox"/>	<input type="checkbox"/>	<input type="checkbox"/>	<b>SUBTOTAL</b>		<b>303,210</b>
TILE/COMPO	<input type="checkbox"/>	<input checked="" type="checkbox"/>	<input type="checkbox"/>	<input type="checkbox"/>	<input type="checkbox"/>	MULTI-FAMILY #	0	0
CARPET	<input type="checkbox"/>	<input checked="" type="checkbox"/>	<input type="checkbox"/>	<input type="checkbox"/>	<input type="checkbox"/>	BUILDING TYPE	100%	0
<b>INT. FINISH</b>	<b>B</b>	<b>1</b>	<b>2</b>	<b>3</b>	<b>U</b>	BSMT FINISH	0 S.F.	0
PLASTER/DW	<input type="checkbox"/>	<input checked="" type="checkbox"/>	<input type="checkbox"/>	<input type="checkbox"/>	<input type="checkbox"/>	FIREPLACE #	1	4,400
PANELING	<input type="checkbox"/>	<input type="checkbox"/>	<input type="checkbox"/>	<input type="checkbox"/>	<input type="checkbox"/>	HEATING	0 S.F.	0
UNFINISHED	<input checked="" type="checkbox"/>	<input type="checkbox"/>	<input type="checkbox"/>	<input type="checkbox"/>	<input type="checkbox"/>	AIR COND	2,584 S.F.	4,260
<b>ACCOMMODATIONS</b>						PLUMBING #	6	7,260
# OF ROOMS		7				GARAGES & CARPORTS		19,600
BEDROOMS		3				EXTRA FEATURES		10,700
FIREPLACES		1				<b>SUBTOTAL</b>		<b>349,430</b>
HEAT & AC	<b>B</b>	<b>1</b>	<b>2</b>	<b>3</b>	<b>U</b>	GRADE FACTOR		100 %
NO HEAT	<input type="checkbox"/>	<input type="checkbox"/>	<input type="checkbox"/>	<input type="checkbox"/>	<input type="checkbox"/>	<b>UNADJUSTED VALUE</b>		<b>349,430</b>
CTRL HEAT	<input type="checkbox"/>	<input checked="" type="checkbox"/>	<input type="checkbox"/>	<input type="checkbox"/>	<input type="checkbox"/>	FACTOR		100 %
HW/STEAM	<input type="checkbox"/>	<input type="checkbox"/>	<input type="checkbox"/>	<input type="checkbox"/>	<input type="checkbox"/>			
ELECTRIC	<input type="checkbox"/>	<input type="checkbox"/>	<input type="checkbox"/>	<input type="checkbox"/>	<input type="checkbox"/>			
HEAT PUMP	<input type="checkbox"/>	<input type="checkbox"/>	<input type="checkbox"/>	<input type="checkbox"/>	<input type="checkbox"/>			
FLR/WALL	<input type="checkbox"/>	<input type="checkbox"/>	<input type="checkbox"/>	<input type="checkbox"/>	<input type="checkbox"/>			
STVE/SPCE	<input type="checkbox"/>	<input type="checkbox"/>	<input type="checkbox"/>	<input type="checkbox"/>	<input type="checkbox"/>			
GEOHERMAL	<input type="checkbox"/>	<input type="checkbox"/>	<input type="checkbox"/>	<input type="checkbox"/>	<input type="checkbox"/>			
OUTSIDE	<input type="checkbox"/>	<input type="checkbox"/>	<input type="checkbox"/>	<input type="checkbox"/>	<input type="checkbox"/>			
CTRL A/C	<input type="checkbox"/>	<input checked="" type="checkbox"/>	<input type="checkbox"/>	<input type="checkbox"/>	<input type="checkbox"/>			
<b>PLUMBING</b>								
X FULL BATH		2						
X HALF BATH								
X FIXTURES								

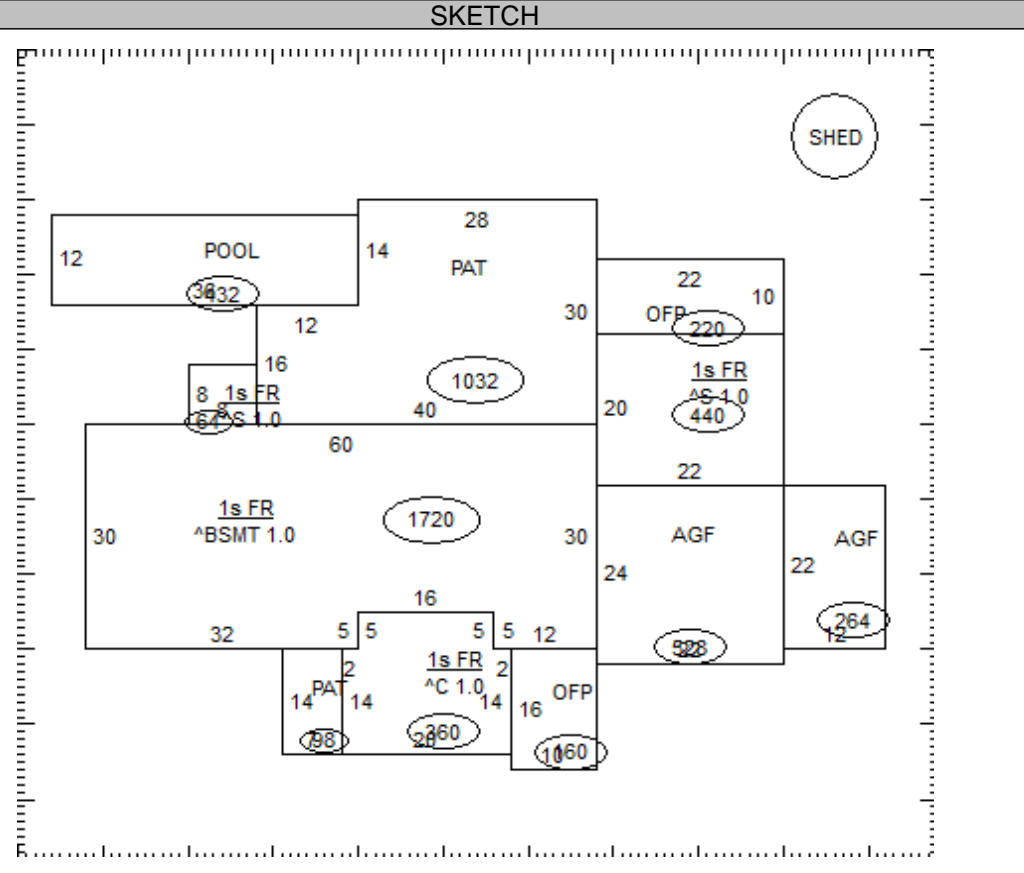

OCCUPANCY	ST.HT	SIZE	AREA	GRADE	PRICE	AGE	REMD	CND	UNADJ VAL	PHYS	PHYS VAL	FUNC	TRUE VAL
DWELLING	1	SK	2,584	C		1955	2021	G	349,430	22	272,560		354,300
1 Pool - Inground		12x36	432	B	45.00	2017		G	19,440	3	18,860		18,900
2 Shed		8x10	80							100			0
3													
4													
5													
6													
7													
8													
9													
10													
11													

26-144800.0000 TOTAL 373,200

**COMMENTS**

BOR#99-19 LAND VALUE REDUCTION  
 Dwelling has an Economic Factor of 130% (Rollback Basis=\$531,500)

26-144800.0000

**WALLEY CHRISTOPHER B & CAREY L**  
WALLEY CHRISTOPHER B & CAREY L  
6674 LAKE ACRES DR  
CELINA, OH 45822

**LEGAL INFORMATION**  
LAKE ACRES SUBDIVISION #1  
ALSO PT VAC RIGHT OF WAY  
LOT#: 23

	OWNERSHIP	ADDRESS	CITY	STATE	ZIP	DATE	AMOUNT	DEED:CONV#	JS	VALID
1	FISHBAUGH ARTHUR A JR &	6674 LAKE ACRES DR	CELINA	OH	45822	06/11/2003	0	: X : 0	<input type="checkbox"/>	<input type="checkbox"/>
2							0	0	<input type="checkbox"/>	<input type="checkbox"/>
3							0	0	<input type="checkbox"/>	<input type="checkbox"/>

X:  TTO LISTER: HK DATE: 03/21/2022 TIME: 12:00:00 AM  LETTER  LETTER REC'D GIS CODE

STREET/ROAD	TOPOGRAPHY	PU-UTILITIES-PR	NEIGHBORHOOD	INFLUENCE FACTORS	PROPERTY LOCATION	
<input checked="" type="checkbox"/> PAVED <input type="checkbox"/> GRAVEL <input type="checkbox"/> DIRT <input type="checkbox"/> SIDEWALKS <input type="checkbox"/> CURBS	<input checked="" type="checkbox"/> LEVEL <input type="checkbox"/> HIGH <input type="checkbox"/> LOW <input type="checkbox"/> ROLLING <input type="checkbox"/> STANDARD	<input type="checkbox"/> WATER <input type="checkbox"/> SEWER <input checked="" type="checkbox"/> GAS <input checked="" type="checkbox"/> ELECTRIC <input type="checkbox"/> STANDARD	<input checked="" type="checkbox"/> IMPROVING <input type="checkbox"/> STATIC <input type="checkbox"/> DECLINING <input type="checkbox"/> OLD <input type="checkbox"/> STANDARD	<input type="checkbox"/> A. NO ROAD <input type="checkbox"/> B. TOPGRHY <input type="checkbox"/> C. Ex Front <input type="checkbox"/> D. QUANTITY <input type="checkbox"/> E. SZ/SHAPE	<input type="checkbox"/> F. RESTRICT <input type="checkbox"/> G. WOOD LT <input type="checkbox"/> H. VACANCY <input type="checkbox"/> I. WATER FRONT <input checked="" type="checkbox"/> J. OTHER/CDU	6674 LAKE ACRES DR, CELINA COMMENT

LAND COMPUTATIONS							
LAND TYPE	SIZE	M	RATE	C	INF	M	VALUE C
TOTAL						177,200	0

VALUATION SUMMARY							
VALUE YEAR	2018	2017	2017				
REASON FOR CHANGE	NC	RAPP	MISC				
APPRaised	LAND	176,900	176,900	176,900			
VALUE	IMPR	176,400	154,900	144,200			
	TOTAL	353,300	331,800	321,100			
ASSESSED	LAND	61,920	61,920	61,920			
VALUE	IMPR	61,740	54,220	50,470			
	TOTAL	123,660	116,140	112,390			

OCCUPANCY	EXTERIOR
<input type="checkbox"/> SF <input type="checkbox"/> DU <input type="checkbox"/> TR	<input type="checkbox"/> WOOD
<input type="checkbox"/> CONVERSION	<input type="checkbox"/> STUCCO
<b>BUILDING TYPE</b>	<input type="checkbox"/> ALM/VYNL
<input type="checkbox"/> MOBILE HOME	<input type="checkbox"/> CONC BLK
<input type="checkbox"/> BI/TR LEVEL	<input type="checkbox"/> METAL
<input type="checkbox"/> MOD/MAN	<input type="checkbox"/> BRICK
<input type="checkbox"/>	<input type="checkbox"/> STONE

ROOFING	ROOF TYPE
<input type="checkbox"/> METAL	<input type="checkbox"/> GABLE
<input type="checkbox"/> SLT/TLE	<input type="checkbox"/> HIP
<input type="checkbox"/> SHINGLES	<input type="checkbox"/> GAMBREL
<input type="checkbox"/> SHAKES	<input type="checkbox"/> MANSARD
<input type="checkbox"/> COMPOSITE	<input type="checkbox"/> FLAT

FLOORS	B	1	2	3	U
CONCRETE	<input type="checkbox"/>	<input type="checkbox"/>	<input type="checkbox"/>	<input type="checkbox"/>	<input type="checkbox"/>
WOOD	<input type="checkbox"/>	<input type="checkbox"/>	<input type="checkbox"/>	<input type="checkbox"/>	<input type="checkbox"/>
TILE/COMPO	<input type="checkbox"/>	<input type="checkbox"/>	<input type="checkbox"/>	<input type="checkbox"/>	<input type="checkbox"/>
CARPET	<input type="checkbox"/>	<input type="checkbox"/>	<input type="checkbox"/>	<input type="checkbox"/>	<input type="checkbox"/>

INT. FINISH	B	1	2	3	U
PLASTER/DW	<input type="checkbox"/>	<input type="checkbox"/>	<input type="checkbox"/>	<input type="checkbox"/>	<input type="checkbox"/>
PANELING	<input type="checkbox"/>	<input type="checkbox"/>	<input type="checkbox"/>	<input type="checkbox"/>	<input type="checkbox"/>
UNFINISHED	<input type="checkbox"/>	<input type="checkbox"/>	<input type="checkbox"/>	<input type="checkbox"/>	<input type="checkbox"/>

ACCOMMODATIONS	B	1	2	3	U
# OF ROOMS					
BEDROOMS					
FIREPLACES					
HEAT & AC	B	1	2	3	U

NO HEAT	<input type="checkbox"/>	<input type="checkbox"/>	<input type="checkbox"/>	<input type="checkbox"/>	<input type="checkbox"/>
CTRL HEAT	<input type="checkbox"/>	<input type="checkbox"/>	<input type="checkbox"/>	<input type="checkbox"/>	<input type="checkbox"/>
HW/STEAM	<input type="checkbox"/>	<input type="checkbox"/>	<input type="checkbox"/>	<input type="checkbox"/>	<input type="checkbox"/>
ELECTRIC	<input type="checkbox"/>	<input type="checkbox"/>	<input type="checkbox"/>	<input type="checkbox"/>	<input type="checkbox"/>
HEAT PUMP	<input type="checkbox"/>	<input type="checkbox"/>	<input type="checkbox"/>	<input type="checkbox"/>	<input type="checkbox"/>
FLR/WALL	<input type="checkbox"/>	<input type="checkbox"/>	<input type="checkbox"/>	<input type="checkbox"/>	<input type="checkbox"/>
STVE/SPCE	<input type="checkbox"/>	<input type="checkbox"/>	<input type="checkbox"/>	<input type="checkbox"/>	<input type="checkbox"/>
GEO THERMAL	<input type="checkbox"/>	<input type="checkbox"/>	<input type="checkbox"/>	<input type="checkbox"/>	<input type="checkbox"/>
OUTSIDE	<input type="checkbox"/>	<input type="checkbox"/>	<input type="checkbox"/>	<input type="checkbox"/>	<input type="checkbox"/>
CTRL A/C	<input type="checkbox"/>	<input type="checkbox"/>	<input type="checkbox"/>	<input type="checkbox"/>	<input type="checkbox"/>

PLUMBING						BASE <input type="checkbox"/>
X FULL BATH						
X HALF BATH						
X FIXTURES						

FLOOR	AREA	CONST	VALUE
<b>SUBTOTAL</b>			0
MULTI-FAMILY #	0		0
BUILDING TYPE	000%		0
BSMT FINISH	0 S.F.		0
FIREPLACE #	0		0
HEATING	0 S.F.		0
AIR COND	0 S.F.		0
PLUMBING #	0		0
GARAGES & CARPORTS			0
EXTRA FEATURES			0
<b>SUBTOTAL</b>			0
GRADE FACTOR			%
<b>UNADJUSTED VALUE</b>			0
FACTOR			%

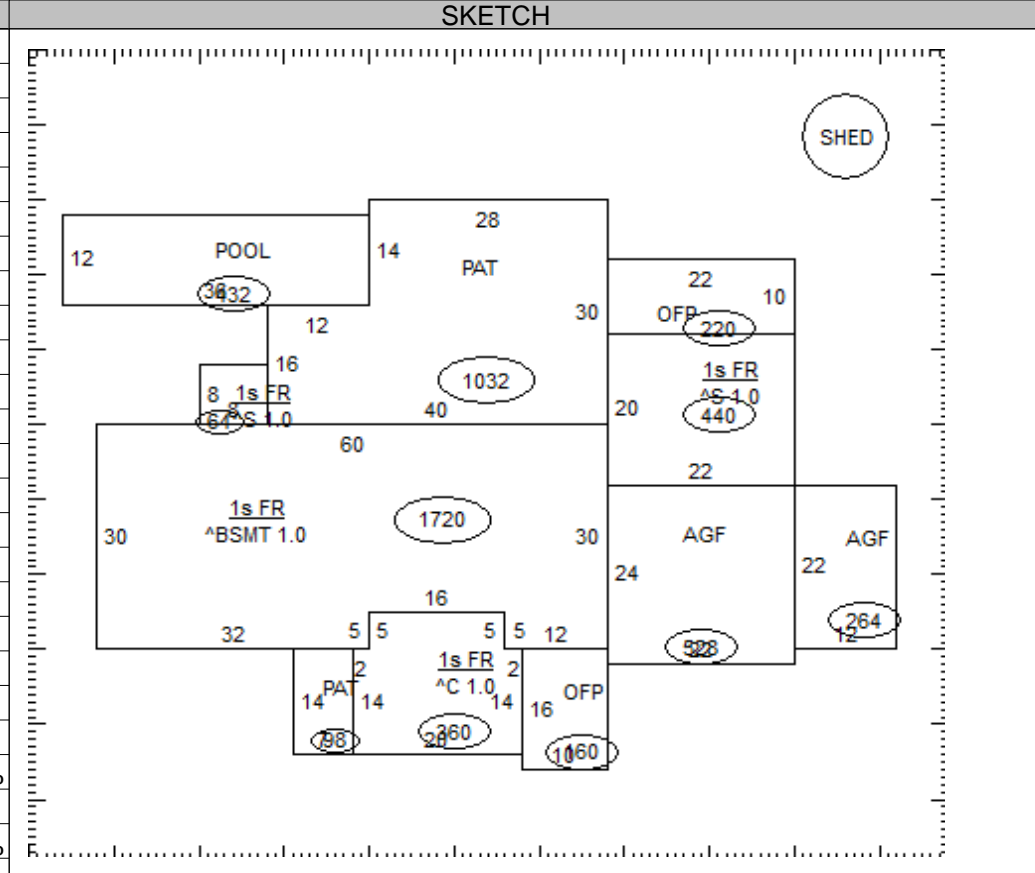

OCCUPANCY	ST.HT	SIZE	AREA	GRADE	PRICE	AGE	REMD	CND	UNADJ VAL	PHYS	PHYS VAL	FUNC	TRUE VAL
DWELLING		SK											
1													
2													
3													
4													
5													
6													
7													
8													
9													
10													
11													

26-144800.0000

TOTAL 0

COMMENTS