

26-129600.0000

SUDHOFF SCOTT A & MINDY ANN

SUDHOFF SCOTT A & MINDY ANN
6902 STEARNS AVE
CELINA, OH 45822

LEGAL INFORMATION

NORTHWOOD SECTION #3
ALSO LOTS 20 & 21
LOT #19

	OWNERSHIP	ADDRESS	CITY	STATE	ZIP	DATE	AMOUNT	DEED:CONV#	JS	VALID
1	SUDHOFF SCOTT A & MINDY	6902 STEARNS AVE	CELINA	OH	45822	01/29/2021	465,000	WDC : 81	<input type="checkbox"/>	<input checked="" type="checkbox"/>
2	MCGOHAN MICHAEL TODD & STACEY LYNNE WINTERS-MCGOHAN TRUSTEES	6902 STEARNS LN	CELINA	OH	45822	03/20/2017	0	3:QCE : X : 0	<input type="checkbox"/>	<input type="checkbox"/>
3	MCGOHAN STACEY L	6902 STEARNS LN	CELINA	OH	45822	06/30/2009	0	QCE : X : 0	<input type="checkbox"/>	<input type="checkbox"/>

X: TTO LISTER: TK DATE: 06/26/2023 TIME: 12:00:00 AM LETTER LETTER REC'D GIS CODE

STREET/ROAD TOPOGRAPHY PU-UTILITIES-PR NEIGHBORHOOD INFLUENCE FACTORS PROPERTY LOCATION

- | | | | | | |
|--|---|--|------------------------------------|--------------------------------------|---|
| <input type="checkbox"/> PAVED | <input checked="" type="checkbox"/> LEVEL | <input type="checkbox"/> WATER | <input type="checkbox"/> IMPROVING | <input type="checkbox"/> A. NO ROAD | <input type="checkbox"/> F. RESTRICT |
| <input checked="" type="checkbox"/> GRAVEL | <input type="checkbox"/> HIGH | <input type="checkbox"/> SEWER | <input type="checkbox"/> STATIC | <input type="checkbox"/> B. TOPGRHY | <input type="checkbox"/> G. WOOD LT |
| <input type="checkbox"/> DIRT | <input type="checkbox"/> LOW | <input type="checkbox"/> GAS | <input type="checkbox"/> DECLINING | <input type="checkbox"/> C. Ex Front | <input type="checkbox"/> H. VACANCY |
| <input type="checkbox"/> SIDEWALKS | <input type="checkbox"/> ROLLING | <input checked="" type="checkbox"/> ELECTRIC | <input type="checkbox"/> OLD | <input type="checkbox"/> D. QUANTITY | <input type="checkbox"/> I. WATER FRONT |
| <input type="checkbox"/> CURBS | <input type="checkbox"/> STANDARD | <input type="checkbox"/> STANDARD | <input type="checkbox"/> STANDARD | <input type="checkbox"/> E. SZ/SHAPE | <input type="checkbox"/> J. OTHER/CDU |

6902 STEARNS LN

COMMENT

TY2022:Net Gen=\$4,531.94, Other Assessment=\$0.00
DE17 CHNG PATIO TO PAVER PATIO/ DSKTP REV
DE11 ADD WDDK
26-129800. & 26-129700. ALSO SITS HERE
DE17 ADDED 3 LOTS TOGETHER//HSE SITS ON ALL
DE22 RMV OWN OCC - DID NOT RETURN APP
DE23 NOH; ADD AGF ADDTN

LAND COMPUTATIONS

LAND TYPE	SIZE	M	RATE	C	INF	M	VALUE	C
F:Front	F139 D103	ST435	DP82	ADJ357			49,600	0
TOTAL							49,600	0

VALUATION SUMMARY

VALUE YEAR	2023	2020	2017	2017	2017
REASON FOR CHANGE	NC	RAPP	RAPP	MISC	MISC
APPRAISED VALUE	49,600	45,100	39,900	45,100	16,500
	<u>LAND</u>				
	<u>IMPR</u>				
	<u>TOTAL</u>				
ASSESSED VALUE	17,360	15,790	13,970	15,790	5,780
	<u>LAND</u>				
	<u>IMPR</u>				
	<u>TOTAL</u>				

OCCUPANCY	EXTERIOR	FLOOR	AREA	CONST	VALUE
<input type="checkbox"/> SF <input type="checkbox"/> DU <input type="checkbox"/> TR	<input type="checkbox"/> WOOD				
<input type="checkbox"/> CONVERSION	<input type="checkbox"/> STUCCO				
BUILDING TYPE	<input type="checkbox"/> ALM/VYNL				
<input type="checkbox"/> MOBILE HOME	<input type="checkbox"/> CONC BLK				
<input type="checkbox"/> BI/TR LEVEL	<input type="checkbox"/> METAL				
<input type="checkbox"/> MOD/MAN	<input type="checkbox"/> BRICK				
<input type="checkbox"/>	<input type="checkbox"/> STONE				

ROOFING	ROOF TYPE
<input type="checkbox"/> METAL	<input type="checkbox"/> GABLE
<input type="checkbox"/> SLT/TLE	<input type="checkbox"/> HIP
<input type="checkbox"/> SHINGLES	<input type="checkbox"/> GAMBREL
<input type="checkbox"/> SHAKES	<input type="checkbox"/> MANSARD
<input type="checkbox"/> COMPOSITE	<input type="checkbox"/> FLAT

SUBTOTAL		0
MULTI-FAMILY #	0	0
BUILDING TYPE	000%	0
BSMT FINISH	0 S.F.	0
FIREPLACE #	0	0
HEATING	0 S.F.	0
AIR COND	0 S.F.	0
PLUMBING #	0	0
GARAGES & CARPORTS		0
EXTRA FEATURES		0
SUBTOTAL		0
GRADE FACTOR		%
UNADJUSTED VALUE		0
FACTOR		%

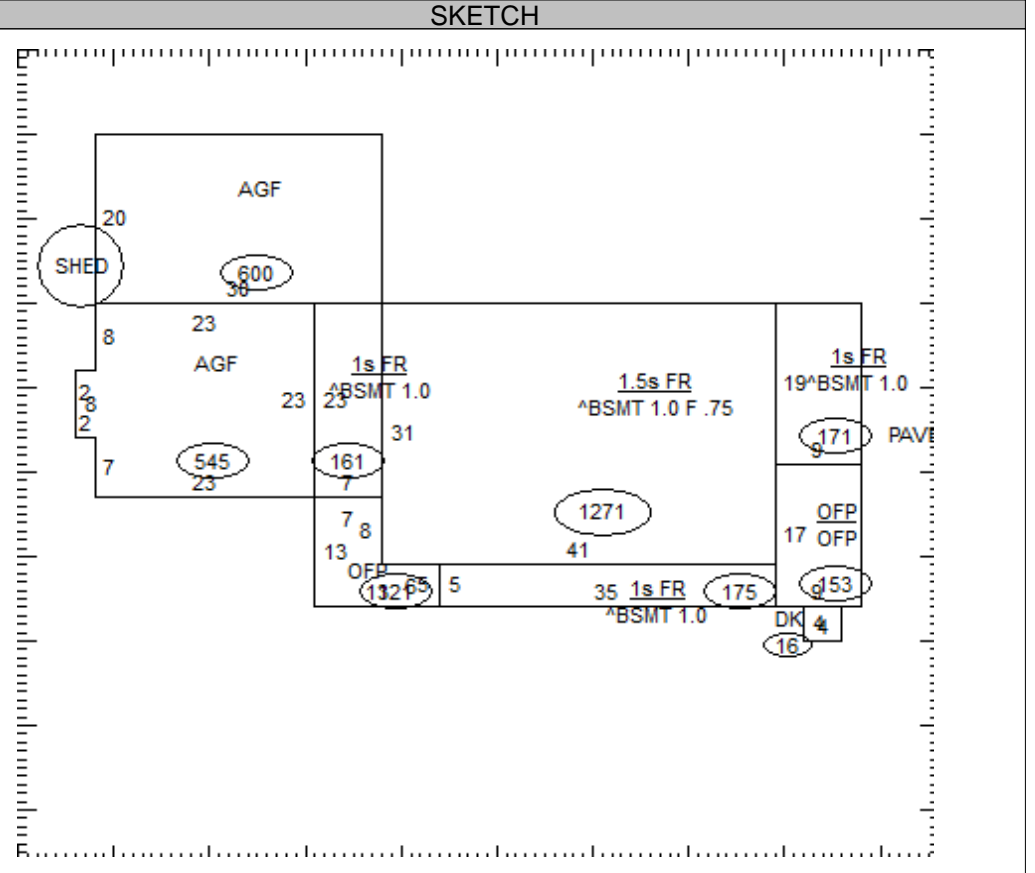

OCCUPANCY	ST.HT	SIZE	AREA	GRADE	PRICE	AGE	REMD	CND	UNADJ VAL	PHYS	PHYS VAL	FUNC	TRUE VAL
DWELLING		SK											
1													
2													
3													
4													
5													
6													
7													
8													
9													
10													
11													

26-129600.0000	TOTAL	0
----------------	--------------	---

COMMENTS