

26-110500.0000

CISCO GALEN B
CISCO GALEN B
604 ELMWOOD LN
CELINA, OH 45822

LEGAL INFORMATION
NORTHWOOD SECTION D
ALSO LOT 9 & PT LOT 8
RTS: 003-06-02 LOT#: 10

QUALIFIED CREDITS:
HOMESTEAD

	OWNERSHIP	ADDRESS	CITY	STATE	ZIP	DATE	AMOUNT	DEED:CONV#	JS	VALID
1	CISCO GALEN B	604 ELMWOOD LN	CELINA	OH	45822	06/29/2020	0	QCE : X : 0	<input type="checkbox"/>	<input type="checkbox"/>
2	CISCO GALEN B & MARTHA J	604 ELMWOOD LN	CELINA	OH	45822	02/25/2016	0	2:QCE : X : 0	<input type="checkbox"/>	<input type="checkbox"/>
3	CISCO GALEN B & MARTHA J	604 ELMWOOD LN	CELINA	OH	45822	05/18/2005	0	QCC : X : 0	<input type="checkbox"/>	<input type="checkbox"/>

X: TTO LISTER: DATE: 12/09/2010 TIME: 12:00:00 AM LETTER LETTER REC'D GIS CODE

STREET/ROAD	TOPOGRAPHY	PU-UTILITIES-PR	NEIGHBORHOOD	INFLUENCE FACTORS				PROPERTY LOCATION			
<input checked="" type="checkbox"/> PAVED	<input checked="" type="checkbox"/> LEVEL	<input type="checkbox"/> WATER	<input type="checkbox"/> IMPROVING	<input type="checkbox"/> A. NO ROAD	<input type="checkbox"/> F. RESTRICT	604 ELMWOOD LN, CELINA					
<input type="checkbox"/> GRAVEL	<input type="checkbox"/> HIGH	<input type="checkbox"/> SEWER	<input type="checkbox"/> STATIC	<input type="checkbox"/> B. TOPGRHY	<input type="checkbox"/> G. WOOD LT	COMMENT					
<input type="checkbox"/> DIRT	<input type="checkbox"/> LOW	<input type="checkbox"/> GAS	<input type="checkbox"/> DECLINING	<input type="checkbox"/> C. Ex Front	<input type="checkbox"/> H. VACANCY	TY2022:Net Gen=\$4,825.56, Other					
<input type="checkbox"/> SIDEWALKS	<input type="checkbox"/> ROLLING	<input checked="" type="checkbox"/> ELECTRIC	<input type="checkbox"/> OLD	<input type="checkbox"/> D. QUANTITY	<input type="checkbox"/> I. WATER FRONT	Assessment=\$0.00					
<input type="checkbox"/> CURBS	<input type="checkbox"/> STANDARD	<input type="checkbox"/> STANDARD	<input type="checkbox"/> STANDARD	<input type="checkbox"/> E. SZ/SHAPE	<input type="checkbox"/> J. OTHER/CDU	46 ELMWOOD LN 0					
LAND COMPUTATIONS											
LAND TYPE	SIZE	M	RATE	C	INF	M	VALUE	C			
F:Front	F20 D88			ST650 DP76 ADJ494			9,900	0	DE11 ADD OMP UNDER BAL		
F:Front	F93 D112			ST650 DP86 ADJ559			52,000	0	DE - 05 Corrected sketch		
									DE15 PER DATA MAILER ADD SHED		
									DE17 ADD BW'S AND CORR PAT SIZE/DSKTOP REV		
									DE17 ADDED LOTS TOGETHER//HSE SITS ON ALL		
TOTAL							61,900	0			

VALUATION SUMMARY

VALUE YEAR	2023	2020	2017	2017	2017			
REASON FOR CHANGE	RAPP	RAPP	RAPP	MISC	MISC			
APPRAISED VALUE	<u>LAND</u> 61,900	47,100	42,800	57,100	25,800			
	<u>IMPR</u> 338,900	279,900	260,600	239,200	239,200			
	<u>TOTAL</u> 400,800	327,000	303,400	296,300	265,000			
ASSESSED VALUE	<u>LAND</u> 21,670	16,490	14,980	19,990	9,030			
	<u>IMPR</u> 118,620	97,970	91,210	83,720	83,720			
	<u>TOTAL</u> 140,290	114,460	106,190	103,710	92,750			

OCCUPANCY		EXTERIOR		FLOOR	AREA	CONST	VALUE
<input checked="" type="checkbox"/> SF	<input type="checkbox"/> DU	<input type="checkbox"/> TR	<input type="checkbox"/> WOOD	1	2071	FR	239,530
<input type="checkbox"/> CONVERSION			<input type="checkbox"/> STUCCO	2ND	717	FR	39,810
BUILDING TYPE			<input checked="" type="checkbox"/> ALM/VYNL	+	0	FR	9,880
<input type="checkbox"/> MOBILE HOME			<input type="checkbox"/> CONC BLK				
<input type="checkbox"/> BI/TR LEVEL			<input type="checkbox"/> METAL				
<input type="checkbox"/> MOD/MAN			<input type="checkbox"/> BRICK				
<input type="checkbox"/>			<input type="checkbox"/> STONE				
ROOFING		ROOF TYPE					
<input type="checkbox"/> METAL			<input checked="" type="checkbox"/> GABLE				
<input type="checkbox"/> SLT/TLE			<input type="checkbox"/> HIP				
<input checked="" type="checkbox"/> SHINGLES			<input type="checkbox"/> GAMBREL				
<input type="checkbox"/> SHAKES			<input type="checkbox"/> MANSARD				
<input type="checkbox"/> COMPOSITE			<input type="checkbox"/> FLAT				

FLOORS		B	1	2	3	U	SUBTOTAL	289,220	
CONCRETE	<input type="checkbox"/>	<input type="checkbox"/>	<input type="checkbox"/>	<input type="checkbox"/>	<input type="checkbox"/>	<input type="checkbox"/>	MULTI-FAMILY #	0	
WOOD	<input type="checkbox"/>	<input checked="" type="checkbox"/>	<input type="checkbox"/>	<input checked="" type="checkbox"/>	<input type="checkbox"/>	<input type="checkbox"/>	BUILDING TYPE	100%	
TILE/COMPO	<input type="checkbox"/>	<input checked="" type="checkbox"/>	<input checked="" type="checkbox"/>	<input type="checkbox"/>	<input type="checkbox"/>	<input type="checkbox"/>	BSMT FINISH	0 S.F.	
CARPET	<input type="checkbox"/>	<input checked="" type="checkbox"/>	<input checked="" type="checkbox"/>	<input type="checkbox"/>	<input type="checkbox"/>	<input type="checkbox"/>	FIREPLACE #	2	
INT. FINISH		B	1	2	3	U	HEATING	0 S.F.	
PLASTER/DW	<input type="checkbox"/>	<input checked="" type="checkbox"/>	<input checked="" type="checkbox"/>	<input type="checkbox"/>	<input type="checkbox"/>	<input type="checkbox"/>	AIR COND	2,788 S.F.	
PANELING	<input type="checkbox"/>	<input type="checkbox"/>	<input type="checkbox"/>	<input type="checkbox"/>	<input type="checkbox"/>	<input type="checkbox"/>	PLUMBING #	5	
UNFINISHED	<input type="checkbox"/>	<input type="checkbox"/>	<input type="checkbox"/>	<input checked="" type="checkbox"/>	<input type="checkbox"/>	<input type="checkbox"/>	GARAGES & CARPORTS	23,500	
ACCOMMODATIONS								EXTRA FEATURES	47,400
# OF ROOMS		5	4				SUBTOTAL	379,570	
BEDROOMS		1	2				GRADE FACTOR	120 %	
FIREPLACES		2					UNADJUSTED VALUE	455,480	
HEAT & AC	B	1	2	3	U			FACTOR	100 %

OCCUPANCY	ST.HT	SIZE	AREA	GRADE	PRICE	AGE	REMD	CND	UNADJ VAL	PHYS	PHYS VAL	FUNC	TRUE VAL
DWELLING	2	SK	2,788	B		1997		A	455,480	22	355,270		337,500
1 Shed		10x16	160	C	9.90	2014		A	1,580	13	1,370		1,400
2													
3													
4													
5													
6													
7													
8													
9													
10													
11													

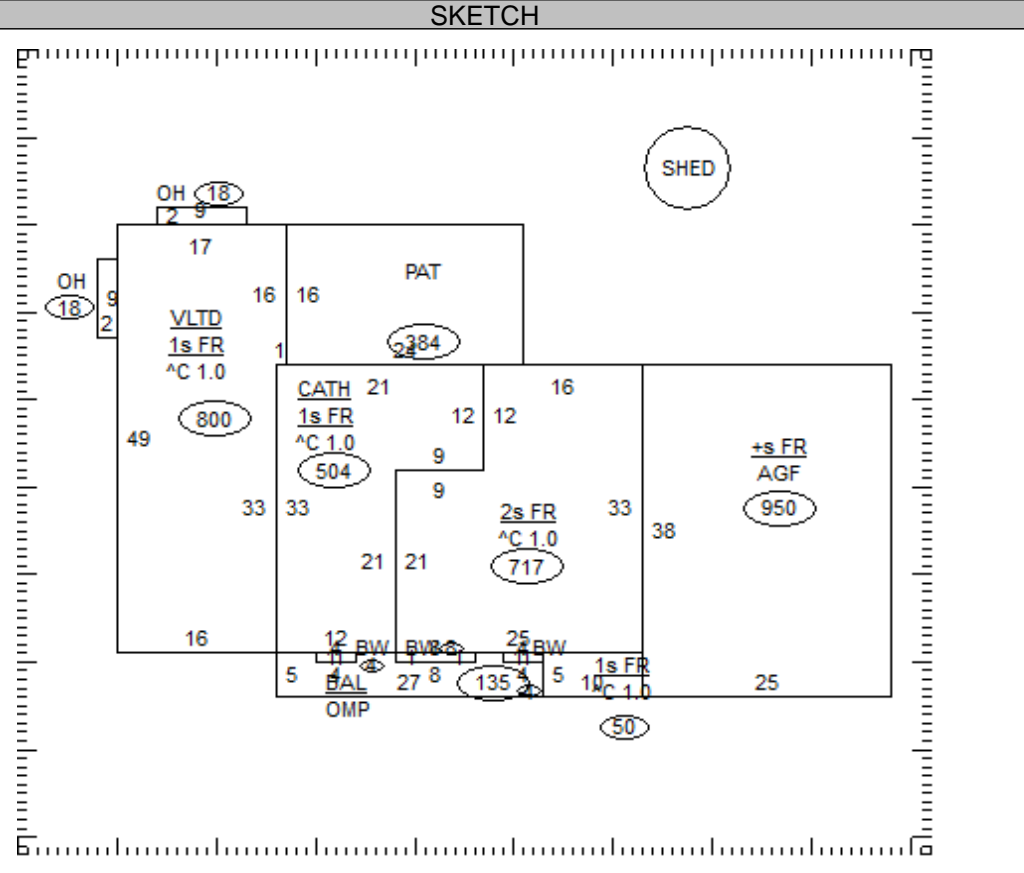

26-110500.0000

TOTAL 338,900

COMMENTS

BRICK TRIM 83X8
 Dwelling has an Economic Factor of 95% (Rollback Basis=\$399,400)

26-110500.0000

CISCO GALEN B

CISCO GALEN B
604 ELMWOOD LN
CELINA, OH 45822

LEGAL INFORMATION

NORTHWOOD SECTION D
ALSO LOT 9 & PT LOT 8
RTS: 003-06-02 LOT#: 10

QUALIFIED CREDITS:
HOMESTEAD

	OWNERSHIP	ADDRESS	CITY	STATE	ZIP	DATE	AMOUNT	DEED:CONV#	JS	VALID
1	CISCO GALEN B & MARTHA J	604 ELMWOOD LN	CELINA	OH	45822 -1986	10/18/1995	68,000	: A-M : 0	<input type="checkbox"/>	<input type="checkbox"/>
2							0	0	<input type="checkbox"/>	<input type="checkbox"/>
3							0	0	<input type="checkbox"/>	<input type="checkbox"/>

X:	<input type="checkbox"/> TTO	LISTER:	DATE: 12/09/2010	TIME: 12:00:00 AM	<input type="checkbox"/> LETTER	<input type="checkbox"/> LETTER REC'D	GIS CODE
----	------------------------------	---------	------------------	-------------------	---------------------------------	---------------------------------------	----------

STREET/ROAD	TOPOGRAPHY	PU-UTILITIES-PR	NEIGHBORHOOD	INFLUENCE FACTORS	PROPERTY LOCATION
<input checked="" type="checkbox"/> PAVED	<input checked="" type="checkbox"/> LEVEL	<input type="checkbox"/> WATER <input type="checkbox"/>	<input type="checkbox"/> IMPROVING	<input type="checkbox"/> A. NO ROAD <input type="checkbox"/> F. RESTRICT	604 ELMWOOD LN, CELINA COMMENT
<input type="checkbox"/> GRAVEL	<input type="checkbox"/> HIGH	<input type="checkbox"/> SEWER <input type="checkbox"/>	<input type="checkbox"/> STATIC	<input type="checkbox"/> B. TOPGRHY <input type="checkbox"/> G. WOOD LT	
<input type="checkbox"/> DIRT	<input type="checkbox"/> LOW	<input type="checkbox"/> GAS <input type="checkbox"/>	<input type="checkbox"/> DECLINING	<input type="checkbox"/> C. Ex Front <input type="checkbox"/> H. VACANCY	
<input type="checkbox"/> SIDEWALKS	<input type="checkbox"/> ROLLING	<input checked="" type="checkbox"/> ELECTRIC <input type="checkbox"/>	<input type="checkbox"/> OLD	<input type="checkbox"/> D. QUANTITY <input type="checkbox"/> I. WATER FRONT	
<input type="checkbox"/> CURBS	<input type="checkbox"/> STANDARD	<input type="checkbox"/> STANDARD <input type="checkbox"/>	<input type="checkbox"/> STANDARD	<input type="checkbox"/> E. SZ/SHAPE <input type="checkbox"/> J. OTHER/CDU	

LAND COMPUTATIONS							
LAND TYPE	SIZE	M	RATE	C	INF	M	VALUE C
TOTAL						61,900	0

VALUATION SUMMARY

VALUE YEAR							
REASON FOR CHANGE							
APPRaised	<u>LAND</u>						
VALUE	<u>IMPR</u>						
	<u>TOTAL</u>						
ASSESSED	<u>LAND</u>						
VALUE	<u>IMPR</u>						
	<u>TOTAL</u>						

OCCUPANCY	EXTERIOR	FLOOR	AREA	CONST	VALUE	SKETCH
<input type="checkbox"/> SF <input type="checkbox"/> DU <input type="checkbox"/> TR	<input type="checkbox"/> WOOD					
<input type="checkbox"/> CONVERSION	<input type="checkbox"/> STUCCO					
BUILDING TYPE	<input type="checkbox"/> ALM/VYNL					
<input type="checkbox"/> MOBILE HOME	<input type="checkbox"/> CONC BLK					
<input type="checkbox"/> BI/TR LEVEL	<input type="checkbox"/> METAL					
<input type="checkbox"/> MOD/MAN	<input type="checkbox"/> BRICK					
<input type="checkbox"/>	<input type="checkbox"/> STONE					
ROOFING	ROOF TYPE					
<input type="checkbox"/> METAL	<input type="checkbox"/> GABLE					
<input type="checkbox"/> SLT/TLE	<input type="checkbox"/> HIP					
<input type="checkbox"/> SHINGLES	<input type="checkbox"/> GAMBREL					
<input type="checkbox"/> SHAKES	<input type="checkbox"/> MANSARD					
<input type="checkbox"/> COMPOSITE	<input type="checkbox"/> FLAT					

SUBTOTAL					0
MULTI-FAMILY #	0				0
BUILDING TYPE	000%				0
BSMT FINISH	0 S.F.				0
FIREPLACE #	0				0
HEATING	0 S.F.				0
AIR COND	0 S.F.				0
PLUMBING #	0				0
GARAGES & CARPORTS					0
EXTRA FEATURES					0
SUBTOTAL					0
GRADE FACTOR					%
UNADJUSTED VALUE					0
FACTOR					%

FLOORS						B	1	2	3	U
CONCRETE	<input type="checkbox"/>	<input type="checkbox"/>	<input type="checkbox"/>	<input type="checkbox"/>	<input type="checkbox"/>					
WOOD	<input type="checkbox"/>	<input type="checkbox"/>	<input type="checkbox"/>	<input type="checkbox"/>	<input type="checkbox"/>					
TILE/COMPO	<input type="checkbox"/>	<input type="checkbox"/>	<input type="checkbox"/>	<input type="checkbox"/>	<input type="checkbox"/>					
CARPET	<input type="checkbox"/>	<input type="checkbox"/>	<input type="checkbox"/>	<input type="checkbox"/>	<input type="checkbox"/>					
INT. FINISH						B	1	2	3	U
PLASTER/DW	<input type="checkbox"/>	<input type="checkbox"/>	<input type="checkbox"/>	<input type="checkbox"/>	<input type="checkbox"/>					
PANELING	<input type="checkbox"/>	<input type="checkbox"/>	<input type="checkbox"/>	<input type="checkbox"/>	<input type="checkbox"/>					
UNFINISHED	<input type="checkbox"/>	<input type="checkbox"/>	<input type="checkbox"/>	<input type="checkbox"/>	<input type="checkbox"/>					
ACCOMMODATIONS										
# OF ROOMS										
BEDROOMS										
FIREPLACES										
HEAT & AC						B	1	2	3	U
NO HEAT	<input type="checkbox"/>	<input type="checkbox"/>	<input type="checkbox"/>	<input type="checkbox"/>	<input type="checkbox"/>					
CTRL HEAT	<input type="checkbox"/>	<input type="checkbox"/>	<input type="checkbox"/>	<input type="checkbox"/>	<input type="checkbox"/>					
HW/STEAM	<input type="checkbox"/>	<input type="checkbox"/>	<input type="checkbox"/>	<input type="checkbox"/>	<input type="checkbox"/>					
ELECTRIC	<input type="checkbox"/>	<input type="checkbox"/>	<input type="checkbox"/>	<input type="checkbox"/>	<input type="checkbox"/>					
HEAT PUMP	<input type="checkbox"/>	<input type="checkbox"/>	<input type="checkbox"/>	<input type="checkbox"/>	<input type="checkbox"/>					
FLR/WALL	<input type="checkbox"/>	<input type="checkbox"/>	<input type="checkbox"/>	<input type="checkbox"/>	<input type="checkbox"/>					
STVE/SPCE	<input type="checkbox"/>	<input type="checkbox"/>	<input type="checkbox"/>	<input type="checkbox"/>	<input type="checkbox"/>					
GEOHERMAL	<input type="checkbox"/>	<input type="checkbox"/>	<input type="checkbox"/>	<input type="checkbox"/>	<input type="checkbox"/>					
OUTSIDE	<input type="checkbox"/>	<input type="checkbox"/>	<input type="checkbox"/>	<input type="checkbox"/>	<input type="checkbox"/>					
CTRL A/C	<input type="checkbox"/>	<input type="checkbox"/>	<input type="checkbox"/>	<input type="checkbox"/>	<input type="checkbox"/>					
PLUMBING						BASE <input type="checkbox"/>				
X FULL BATH										
X HALF BATH										
X FIXTURES										

OCCUPANCY	ST.HT	SIZE	AREA	GRADE	PRICE	AGE	REMD	CND	UNADJ VAL	PHYS	PHYS VAL	FUNC	TRUE VAL
DWELLING		SK											
1													
2													
3													
4													
5													
6													
7													
8													
9													
10													
11													

26-110500.0000 TOTAL 0

COMMENTS