

JEFFERSON TWP / CELINA SD

09-02-151-014

Property Class: 510

Neighborhood
265LF80-LF80

Map: 07
Block: 03
Card: 10

Bk: Pg:

26-101500.0000

FRYSINGER JAY V & JUDY ANN

FRYSINGER JAY V & JUDY ANN

8080 STATE ROUTE 703

CELINA, OH 45822

LEGAL INFORMATION

PT SW NW

RTS: 003-06-02
Acres:0.8500

**QUALIFIED CREDITS:
HOMESTEAD**

	OWNERSHIP	ADDRESS	CITY	STATE	ZIP	DATE	AMOUNT	DEED:CONV#	JS	VALID
1	FRYSINGER JAY V & JUDY	8080 STATE ROUTE 703	CELINA	OH	45822	08/11/2023	902,000	WDC : 478	<input type="checkbox"/>	<input checked="" type="checkbox"/>
2	BOWLING JOHN F	8080 STATE ROUTE 703	CELINA	OH	45822	12/24/2014	0	QCE : X : 0	<input type="checkbox"/>	<input type="checkbox"/>
3	BOWLING JOHN & PARK	8080 STATE ROUTE 703	CELINA	OH	45822	12/24/2014	0	QCE : X : 0	<input type="checkbox"/>	<input type="checkbox"/>

X: TTO LISTER: DF DATE: 05/18/2005 TIME: 12:00:00 AM LETTER LETTER REC'D GIS CODE

STREET/ROAD TOPOGRAPHY PU-UTILITIES-PR NEIGHBORHOOD INFLUENCE FACTORS PROPERTY LOCATION

PAVED LEVEL WATER IMPROVING A. NO ROAD F. RESTRICT
 GRAVEL HIGH SEWER STATIC B. TOPGRHY G. WOOD LT
 DIRT LOW GAS DECLINING C. Ex Front H. VACANCY
 SIDEWALKS ROLLING ELECTRIC OLD D. QUANTITY I. WATER FRONT
 CURBS STANDARD STANDARD STANDARD E. SZ/SHAPE J. OTHER/CDU

8080 ST RTE 703

COMMENT

TY2022:Net Gen=\$6,352.44, Other Assessment=\$0.00
DE09 CORR FP PER DATA MAILER
WATER FRONT
(Mod SM:)855

LAND COMPUTATIONS

LAND TYPE	SIZE	M	RATE	C	INF	M	VALUE	C
HS:Home Site <1 @ 97000*0.97	AC:0.85	94090				94,100	0	
					TOTAL	94,100	0	

VALUATION SUMMARY

VALUE YEAR	2023	2020	2017				
REASON FOR CHANGE	RAPP	RAPP	RAPP				
APPRAISED	LAND	94,100	85,400	77,600			
VALUE	IMPR	545,800	337,000	317,300			
	TOTAL	639,900	422,400	394,900			
ASSESSED	LAND	32,940	29,890	27,160			
VALUE	IMPR	191,030	117,950	111,060			
	TOTAL	223,970	147,840	138,220			

OCCUPANCY
 SF DU TR
 CONVERSION
BUILDING TYPE
 MOBILE HOME
 BI/TR LEVEL
 MOD/MAN

EXTERIOR
 WOOD
 STUCCO
 ALM/VYNL
 CONC BLK
 METAL
 BRICK
 STONE

FLOOR	AREA	CONST	VALUE
1	3295	FR	336,290
+	0	FR	36,440
SUBTOTAL			372,730

ROOFING
 METAL
 SLT/TLE
 SHINGLES
 SHAKES
 COMPOSITE

ROOF TYPE
 GABLE
 HIP
 GAMBREL
 MANSARD
 FLAT

FLOORS B 1 2 3 U
 CONCRETE
 WOOD
 TILE/COMPO
 CARPET

INT. FINISH B 1 2 3 U
 PLASTER/DW
 PANELING
 UNFINISHED

ACCOMMODATIONS
 # OF ROOMS 4
 BEDROOMS 3
 FIREPLACES 2

HEAT & AC B 1 2 3 U
 NO HEAT
 CTRL HEAT
 HW/STEAM
 ELECTRIC
 HEAT PUMP
 FLR/WALL
 STVE/SPCE
 GEOTHERMAL
 OUTSIDE
 CTRL A/C

PLUMBING BASE
 X FULL BATH 2
 X HALF BATH
 X FIXTURES 3

MULTI-FAMILY #	0	0
BUILDING TYPE	100%	0
BSMT FINISH	0 S.F.	0
FIREPLACE #	2	8,800
HEATING	0 S.F.	0
AIR COND	3,295 S.F.	5,440
PLUMBING #	9	10,890
GARAGES & CARPORTS		23,800
EXTRA FEATURES		12,900
SUBTOTAL		434,560
GRADE FACTOR		150 %
UNADJUSTED VALUE		651,840
FACTOR		100 %

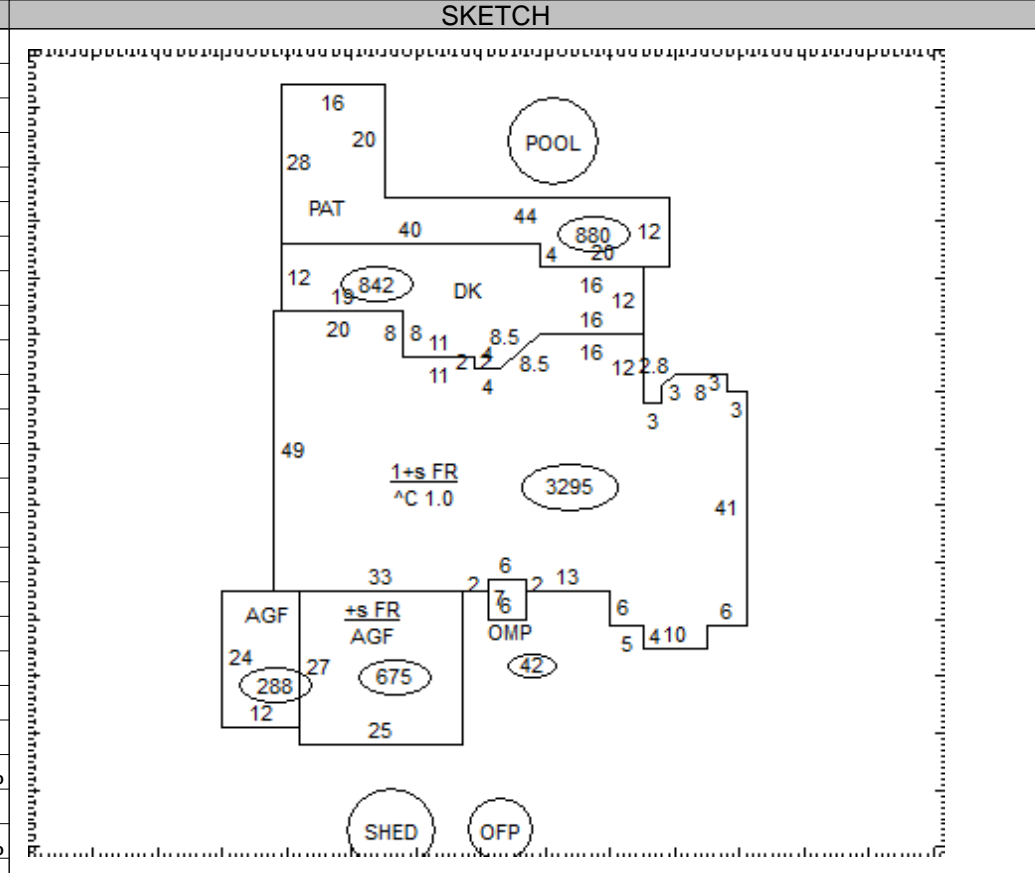

OCCUPANCY	ST.HT	SIZE	AREA	GRADE	PRICE	AGE	REMD	CND	UNADJ VAL	PHYS	PHYS VAL	FUNC	TRUE VAL
DWELLING	1+	SK	3,295	A-		1998		A	651,840	19	527,990		528,000
1 OFFP		0x0	70	C	16.04	1998		A	1,120	37	710		700
2 Pool - Inground		16x42	672	C	37.50	1998		A	25,200	37	15,880		15,900
3 Shed		0x0	250	C	7.70	1998		A	1,930	37	1,220		1,200
4													
5													
6													
7													
8													
9													
10													
11													

26-101500.0000 TOTAL 545,800

COMMENTS
 BRICK TRIM 155 X 8
 Dwelling has an Economic Factor of 100% (Rollback Basis=\$622,100)

OCCUPANCY	EXTERIOR	FLOOR	AREA	CONST	VALUE
<input type="checkbox"/> SF <input type="checkbox"/> DU <input type="checkbox"/> TR	<input type="checkbox"/> WOOD				
<input type="checkbox"/> CONVERSION	<input type="checkbox"/> STUCCO				
BUILDING TYPE	<input type="checkbox"/> ALM/VYNL				
<input type="checkbox"/> MOBILE HOME	<input type="checkbox"/> CONC BLK				
<input type="checkbox"/> BI/TR LEVEL	<input type="checkbox"/> METAL				
<input type="checkbox"/> MOD/MAN	<input type="checkbox"/> BRICK				
<input type="checkbox"/>	<input type="checkbox"/> STONE				

ROOFING	ROOF TYPE
<input type="checkbox"/> METAL	<input type="checkbox"/> GABLE
<input type="checkbox"/> SLT/TLE	<input type="checkbox"/> HIP
<input type="checkbox"/> SHINGLES	<input type="checkbox"/> GAMBREL
<input type="checkbox"/> SHAKES	<input type="checkbox"/> MANSARD
<input type="checkbox"/> COMPOSITE	<input type="checkbox"/> FLAT

FLOORS	B	1	2	3	U
CONCRETE	<input type="checkbox"/>	<input type="checkbox"/>	<input type="checkbox"/>	<input type="checkbox"/>	<input type="checkbox"/>
WOOD	<input type="checkbox"/>	<input type="checkbox"/>	<input type="checkbox"/>	<input type="checkbox"/>	<input type="checkbox"/>
TILE/COMPO	<input type="checkbox"/>	<input type="checkbox"/>	<input type="checkbox"/>	<input type="checkbox"/>	<input type="checkbox"/>
CARPET	<input type="checkbox"/>	<input type="checkbox"/>	<input type="checkbox"/>	<input type="checkbox"/>	<input type="checkbox"/>
INT. FINISH	B	1	2	3	U
PLASTER/DW	<input type="checkbox"/>	<input type="checkbox"/>	<input type="checkbox"/>	<input type="checkbox"/>	<input type="checkbox"/>
PANELING	<input type="checkbox"/>	<input type="checkbox"/>	<input type="checkbox"/>	<input type="checkbox"/>	<input type="checkbox"/>
UNFINISHED	<input type="checkbox"/>	<input type="checkbox"/>	<input type="checkbox"/>	<input type="checkbox"/>	<input type="checkbox"/>
ACCOMMODATIONS					
# OF ROOMS					
BEDROOMS					
FIREPLACES					
HEAT & AC	B	1	2	3	U
NO HEAT	<input type="checkbox"/>	<input type="checkbox"/>	<input type="checkbox"/>	<input type="checkbox"/>	<input type="checkbox"/>
CTRL HEAT	<input type="checkbox"/>	<input type="checkbox"/>	<input type="checkbox"/>	<input type="checkbox"/>	<input type="checkbox"/>
HW/STEAM	<input type="checkbox"/>	<input type="checkbox"/>	<input type="checkbox"/>	<input type="checkbox"/>	<input type="checkbox"/>
ELECTRIC	<input type="checkbox"/>	<input type="checkbox"/>	<input type="checkbox"/>	<input type="checkbox"/>	<input type="checkbox"/>
HEAT PUMP	<input type="checkbox"/>	<input type="checkbox"/>	<input type="checkbox"/>	<input type="checkbox"/>	<input type="checkbox"/>
FLR/WALL	<input type="checkbox"/>	<input type="checkbox"/>	<input type="checkbox"/>	<input type="checkbox"/>	<input type="checkbox"/>
STVE/SPCE	<input type="checkbox"/>	<input type="checkbox"/>	<input type="checkbox"/>	<input type="checkbox"/>	<input type="checkbox"/>
GEOHERMAL	<input type="checkbox"/>	<input type="checkbox"/>	<input type="checkbox"/>	<input type="checkbox"/>	<input type="checkbox"/>
OUTSIDE	<input type="checkbox"/>	<input type="checkbox"/>	<input type="checkbox"/>	<input type="checkbox"/>	<input type="checkbox"/>
CTRL A/C	<input type="checkbox"/>	<input type="checkbox"/>	<input type="checkbox"/>	<input type="checkbox"/>	<input type="checkbox"/>
PLUMBING					BASE <input type="checkbox"/>
X FULL BATH					
X HALF BATH					
X FIXTURES					

SUBTOTAL		0
MULTI-FAMILY #	0	0
BUILDING TYPE	000%	0
BSMT FINISH	0 S.F.	0
FIREPLACE #	0	0
HEATING	0 S.F.	0
AIR COND	0 S.F.	0
PLUMBING #	0	0
GARAGES & CARPORTS		0
EXTRA FEATURES		0
SUBTOTAL		0
GRADE FACTOR		%
UNADJUSTED VALUE		0
FACTOR		%

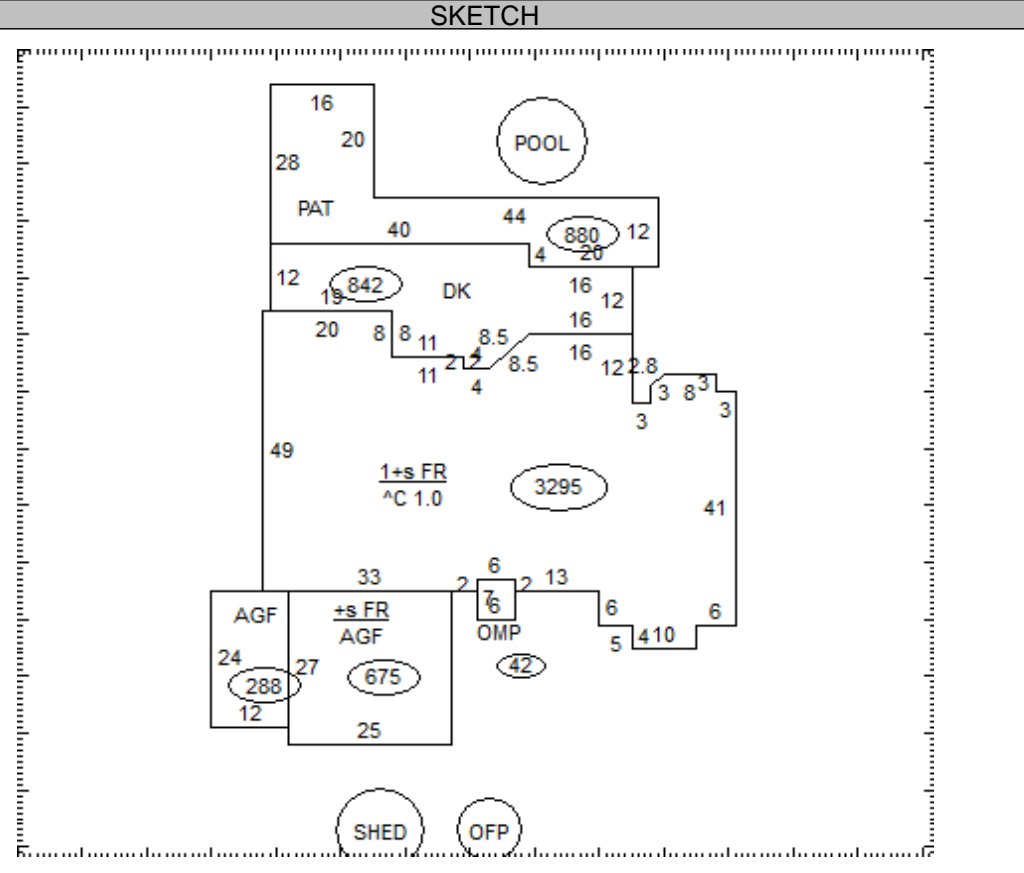

OCCUPANCY	ST.HT	SIZE	AREA	GRADE	PRICE	AGE	REMD	CND	UNADJ VAL	PHYS	PHYS VAL	FUNC	TRUE VAL
DWELLING		SK											
1													
2													
3													
4													
5													
6													
7													
8													
9													
10													
11													

26-101500.0000

TOTAL 0

COMMENTS