

JEFFERSON TWP / CELINA SD

09-01-926-002

26-088400.0000

LEGAL INFORMATION
 SANDY BEACH FRONT CONDO
 UNIT 2
 RTS: 003-06-01

BRUNSWICK GREGORY
 BRUNSWICK GREGORY
 320 FARNSWORTH RD
 SAINT MARYS, OH 45885

	OWNERSHIP	ADDRESS	CITY	STATE	ZIP	DATE	AMOUNT	DEED:CONV#	JS	VALID
1	BRUNSWICK GREGORY	320 FARNSWORTH RD	SAINT MARYS	OH	45885	09/21/2020	268,900	WDC : 685	<input type="checkbox"/>	<input checked="" type="checkbox"/>
2	FISHER GLENN D & LINDA K	2876 HUMMINGBIRD ST	ELIDA	OH	45807	04/30/1999	170,000	: A : 0	<input type="checkbox"/>	<input checked="" type="checkbox"/>
3							0	0	<input type="checkbox"/>	<input type="checkbox"/>

X: TTO LISTER: TS DATE: 12/30/2016 TIME: 12:00:00 AM LETTER LETTER REC'D GIS CODE

STREET/ROAD	TOPOGRAPHY	PU-UTILITIES-PR	NEIGHBORHOOD	INFLUENCE FACTORS		PROPERTY LOCATION
<input checked="" type="checkbox"/> PAVED	<input checked="" type="checkbox"/> LEVEL	<input type="checkbox"/> WATER	<input type="checkbox"/> IMPROVING	<input type="checkbox"/> A. NO ROAD	<input type="checkbox"/> F. RESTRICT	320 FARNSWORTH RD
<input type="checkbox"/> GRAVEL	<input type="checkbox"/> HIGH	<input type="checkbox"/> SEWER	<input type="checkbox"/> STATIC	<input type="checkbox"/> B. TOPGRHY	<input type="checkbox"/> G. WOOD LT	COMMENT
<input type="checkbox"/> DIRT	<input type="checkbox"/> LOW	<input type="checkbox"/> GAS	<input type="checkbox"/> DECLINING	<input type="checkbox"/> C. Ex Front	<input type="checkbox"/> H. VACANCY	TY2022:Net Gen=\$2,792.52, Other
<input type="checkbox"/> SIDEWALKS	<input type="checkbox"/> ROLLING	<input checked="" type="checkbox"/> ELECTRIC	<input type="checkbox"/> OLD	<input type="checkbox"/> D. QUANTITY	<input type="checkbox"/> I. WATER FRONT	Assessment=\$0.00
<input type="checkbox"/> CURBS	<input type="checkbox"/> STANDARD	<input type="checkbox"/> STANDARD	<input type="checkbox"/> STANDARD	<input type="checkbox"/> E. SZ/SHAPE	<input type="checkbox"/> J. OTHER/CDU	DE09 PER DATA MAILER ADDED G FIREPLACE

LAND COMPUTATIONS						
LAND TYPE	SIZE	M	RATE	C	INF	M VALUE C
CL:Condo Land	UNIT PRICED	10000				10,000 0
Total Acres: 1.0000					TOTAL	10,000 0

320 FARNSWORTH RD
COMMENT
 TY2022:Net Gen=\$2,792.52, Other
 Assessment=\$0.00
 DE09 PER DATA MAILER ADDED G FIREPLACE
 DE17 FIELDCHK RVW CHGS: no chg

VALUATION SUMMARY

VALUE YEAR	2023	2020	2017	2017				
REASON FOR CHANGE	RAPP	RAPP	RAPP	MISC				
APPRaised	<u>LAND</u>	10,000	8,400	8,000	8,000			
VALUE	<u>IMPR</u>	253,700	162,600	156,700	141,900			
	<u>TOTAL</u>	263,700	171,000	164,700	149,900			
ASSESSED	<u>LAND</u>	3,500	2,940	2,800	2,800			
VALUE	<u>IMPR</u>	88,800	56,910	54,850	49,670			
	<u>TOTAL</u>	92,300	59,850	57,650	52,470			

OCCUPANCY		EXTERIOR		FLOOR	AREA	CONST	VALUE
<input checked="" type="checkbox"/> SF	<input type="checkbox"/> DU	<input type="checkbox"/> TR	<input checked="" type="checkbox"/> WOOD	1	1242	FR	183,880
<input type="checkbox"/> CONVERSION			<input type="checkbox"/> STUCCO	2ND	559	FR	39,720
BUILDING TYPE							
<input type="checkbox"/> MOBILE HOME			<input type="checkbox"/> ALM/VYNL				
<input type="checkbox"/> BI/TR LEVEL			<input type="checkbox"/> CONC BLK				
<input type="checkbox"/> MOD/MAN			<input type="checkbox"/> METAL				
<input type="checkbox"/>			<input type="checkbox"/> BRICK				
			<input type="checkbox"/> STONE				
ROOFING		ROOF TYPE					
<input type="checkbox"/> METAL			<input checked="" type="checkbox"/> GABLE				
<input type="checkbox"/> SLT/TLE			<input type="checkbox"/> HIP				
<input checked="" type="checkbox"/> SHINGLES			<input type="checkbox"/> GAMBREL				
<input type="checkbox"/> SHAKES			<input type="checkbox"/> MANSARD				
<input type="checkbox"/> COMPOSITE			<input type="checkbox"/> FLAT				

SUBTOTAL					223,600
MULTI-FAMILY #	0				0
BUILDING TYPE	100%				0
BSMT FINISH	0 S.F.				0
FIREPLACE #	1				4,400
HEATING	0 S.F.				0
AIR COND	1,801 S.F.				2,970
PLUMBING #	3				3,630
GARAGES & CARPORTS					0
EXTRA FEATURES					19,900
SUBTOTAL					254,500
GRADE FACTOR					115 %
UNADJUSTED VALUE					292,680
FACTOR					%

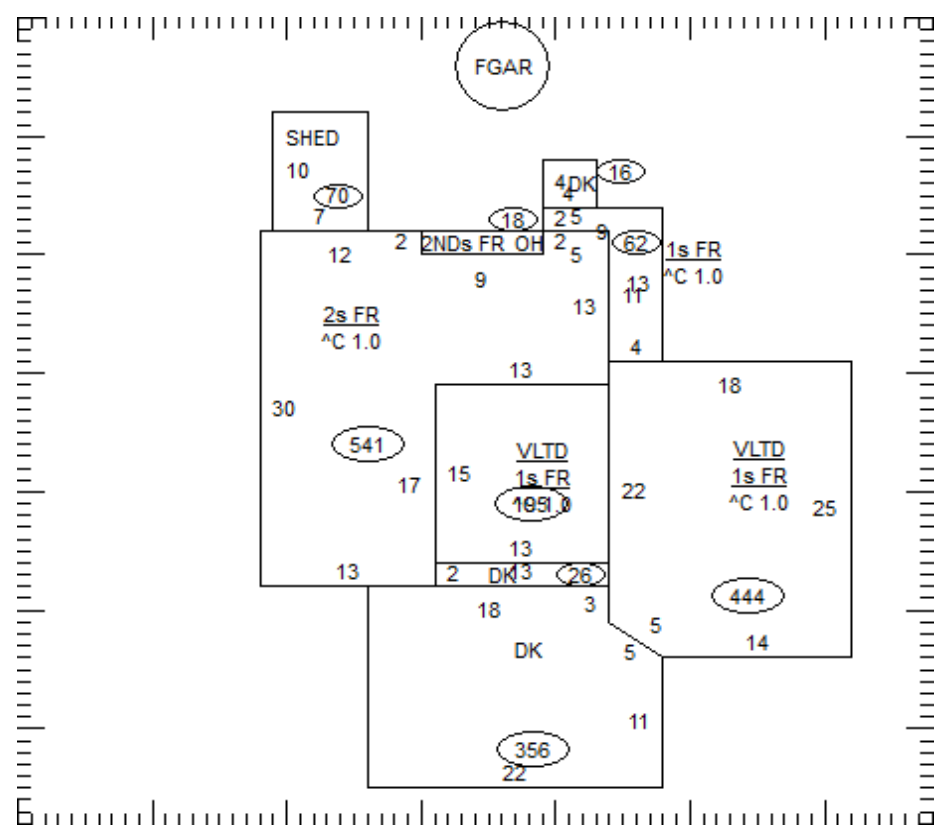

FLOORS		B	1	2	3	U
CONCRETE		<input type="checkbox"/>	<input type="checkbox"/>	<input type="checkbox"/>	<input type="checkbox"/>	<input type="checkbox"/>
WOOD		<input type="checkbox"/>	<input checked="" type="checkbox"/>	<input type="checkbox"/>	<input type="checkbox"/>	<input type="checkbox"/>
TILE/COMPO		<input type="checkbox"/>	<input checked="" type="checkbox"/>	<input type="checkbox"/>	<input type="checkbox"/>	<input type="checkbox"/>
CARPET		<input type="checkbox"/>	<input checked="" type="checkbox"/>	<input checked="" type="checkbox"/>	<input type="checkbox"/>	<input type="checkbox"/>
INT. FINISH		B	1	2	3	U
PLASTER/DW		<input type="checkbox"/>	<input checked="" type="checkbox"/>	<input type="checkbox"/>	<input type="checkbox"/>	<input type="checkbox"/>
PANELING		<input type="checkbox"/>	<input type="checkbox"/>	<input type="checkbox"/>	<input type="checkbox"/>	<input type="checkbox"/>
UNFINISHED		<input type="checkbox"/>	<input type="checkbox"/>	<input type="checkbox"/>	<input type="checkbox"/>	<input type="checkbox"/>

ACCOMMODATIONS						
# OF ROOMS		3	2			
BEDROOMS			2			
FIREPLACES		1				
HEAT & AC		B	1	2	3	U
NO HEAT		<input type="checkbox"/>	<input type="checkbox"/>	<input type="checkbox"/>	<input type="checkbox"/>	<input type="checkbox"/>
CTRL HEAT		<input type="checkbox"/>	<input checked="" type="checkbox"/>	<input checked="" type="checkbox"/>	<input type="checkbox"/>	<input type="checkbox"/>
HW/STEAM		<input type="checkbox"/>	<input type="checkbox"/>	<input type="checkbox"/>	<input type="checkbox"/>	<input type="checkbox"/>
ELECTRIC		<input type="checkbox"/>	<input type="checkbox"/>	<input type="checkbox"/>	<input type="checkbox"/>	<input type="checkbox"/>
HEAT PUMP		<input type="checkbox"/>	<input type="checkbox"/>	<input type="checkbox"/>	<input type="checkbox"/>	<input type="checkbox"/>
FLR/WALL		<input type="checkbox"/>	<input type="checkbox"/>	<input type="checkbox"/>	<input type="checkbox"/>	<input type="checkbox"/>
STVE/SPCE		<input type="checkbox"/>	<input type="checkbox"/>	<input type="checkbox"/>	<input type="checkbox"/>	<input type="checkbox"/>
GEO THERMAL		<input type="checkbox"/>	<input type="checkbox"/>	<input type="checkbox"/>	<input type="checkbox"/>	<input type="checkbox"/>
OUTSIDE		<input type="checkbox"/>	<input type="checkbox"/>	<input type="checkbox"/>	<input type="checkbox"/>	<input type="checkbox"/>
CTRL A/C		<input type="checkbox"/>	<input checked="" type="checkbox"/>	<input checked="" type="checkbox"/>	<input type="checkbox"/>	<input type="checkbox"/>
PLUMBING		BASE <input checked="" type="checkbox"/>				
X FULL BATH		1				
X HALF BATH						
X FIXTURES						

OCCUPANCY	ST.HT	SIZE	AREA	GRADE	PRICE	AGE	REMD	CND	UNADJ VAL	PHYS	PHYS VAL	FUNC	TRUE VAL
DWELLING	2	SK	1,801	B-		1999	2005	A	292,680	17	242,920		242,900
1 Gar - Frame		30x24	720	C	23.70	1999		A	17,060	37	10,750		10,800
2													
3													
4													
5													
6													
7													
8													
9													
10													
11													

26-088400.0000

TOTAL 253,700

COMMENTS
 Dwelling has an Economic Factor of 100%