

26-083000.0000

MCEVOY MICHAEL & AMANDA
MCEVOY MICHAEL & AMANDA
4506 BUCKEYE DR
SAINT MARYS, OH 45885

LEGAL INFORMATION
SANDY BEACH SECTION J
LOTS 8-19
RTS: 003-06-01

	OWNERSHIP	ADDRESS	CITY	STATE	ZIP	DATE	AMOUNT	DEED:CONV#	JS	VALID
1	MCEVOY MICHAEL & AMANDA	4506 BUCKEYE DR	SAINT MARYS	OH	45885	12/07/2020	580,000	WDC : 915	<input type="checkbox"/>	<input checked="" type="checkbox"/>
2	BROWN MATTHEW J & MARY	4506 BUCKEYE DR	SAINT MARYS	OH	45885	05/27/2015	79,000	12:WDC : 330	<input type="checkbox"/>	<input checked="" type="checkbox"/>
3	VAN TREES GREGORY R	9833 ST RT 49	ROCKFORD	OH	45882	04/28/2015	0	12:QCE : X : 0	<input type="checkbox"/>	<input type="checkbox"/>

X: TTO LISTER: HK DATE: 02/22/2022 TIME: 12:00:00 AM LETTER LETTER REC'D GIS CODE

STREET/ROAD **TOPOGRAPHY** **PU-UTILITIES-PR** **NEIGHBORHOOD** **INFLUENCE FACTORS** **PROPERTY LOCATION**

<input type="checkbox"/> PAVED	<input checked="" type="checkbox"/> LEVEL	<input type="checkbox"/> WATER	<input type="checkbox"/> IMPROVING	<input type="checkbox"/> A. NO ROAD	<input type="checkbox"/> F. RESTRICT	4506 BUCKEYE DR
<input type="checkbox"/> GRAVEL	<input type="checkbox"/> HIGH	<input type="checkbox"/> SEWER	<input type="checkbox"/> STATIC	<input type="checkbox"/> B. TOPGRHY	<input type="checkbox"/> G. WOOD LT	COMMENT
<input type="checkbox"/> DIRT	<input type="checkbox"/> LOW	<input type="checkbox"/> GAS	<input type="checkbox"/> DECLINING	<input type="checkbox"/> C. Ex Front	<input type="checkbox"/> H. VACANCY	TY2022:Net Gen=\$6,797.04, Other
<input type="checkbox"/> SIDEWALKS	<input type="checkbox"/> ROLLING	<input checked="" type="checkbox"/> ELECTRIC	<input type="checkbox"/> OLD	<input type="checkbox"/> D. QUANTITY	<input type="checkbox"/> I. WATER FRONT	Assessment=\$0.00
<input type="checkbox"/> CURBS	<input type="checkbox"/> STANDARD	<input type="checkbox"/> STANDARD	<input type="checkbox"/> STANDARD	<input type="checkbox"/> E. SZ/SHAPE	<input type="checkbox"/> J. OTHER/CDU	DE17 TTO/ ALLOW INC FNC

LAND COMPUTATIONS

LAND TYPE	SIZE	M	RATE	C	INF	M	VALUE	C
F:Front	F289 D224	ST335	DP115	ADJ385			111,300	0
						TOTAL	111,300	0

DE17 ADD DWLG/RMV RESTRICTIONS ON LAND
DE20 RMV INC, COR FN BSMNT, COR BATH PER
SOC MEDIA
DE22 ADD SHED

VALUATION SUMMARY

VALUE YEAR	2023	2022	2020	2018	2017			
REASON FOR CHANGE	RAPP	NC	NC	MISC	NC			
APPRAISED	111,300	101,300	101,300	96,500	96,500			
VALUE	IMPR	422,700	324,100	322,200	255,400	293,500		
	TOTAL	534,000	425,400	423,500	351,900	390,000		
ASSESSED	LAND	38,960	35,460	35,460	33,780	33,780		
VALUE	IMPR	147,950	113,440	112,770	89,390	102,730		
	TOTAL	186,910	148,900	148,230	123,170	136,510		

OCCUPANCY
 SF DU TR
 CONVERSION
BUILDING TYPE
 MOBILE HOME
 BI/TR LEVEL
 MOD/MAN

FLOOR	AREA	CONST	VALUE
1	2313	FR	256,740

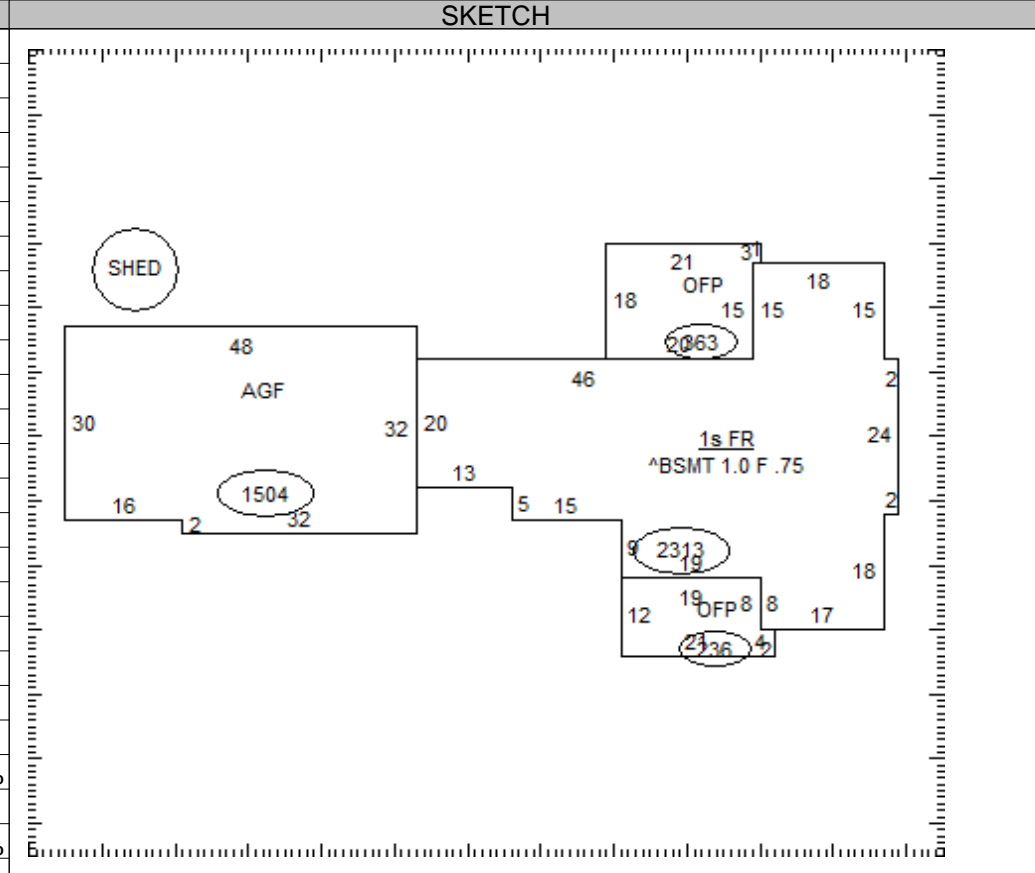

ROOFING
 METAL
 SLT/TLE
 SHINGLES
 SHAKES
 COMPOSITE

ROOF TYPE
 GABLE
 HIP
 GAMBREL
 MANSARD
 FLAT

BSMT	2313		33,080
SUBTOTAL			289,820
MULTI-FAMILY #	0		0
BUILDING TYPE	100%		0
BSMT FINISH	1,735 S.F.		24,810
FIREPLACE #	1		4,400
HEATING	0 S.F.		0
AIR COND	4,048 S.F.		6,680
PLUMBING #	10		12,100
GARAGES & CARPORTS			37,200
EXTRA FEATURES			9,600
SUBTOTAL			384,610
GRADE FACTOR			120 %
UNADJUSTED VALUE			461,530
FACTOR			100 %

FLOORS B 1 2 3 U
 CONCRETE
 WOOD
 TILE/COMPO
 CARPET

FLOORS	B	1	2	3	U
CONCRETE	<input type="checkbox"/>	<input type="checkbox"/>	<input type="checkbox"/>	<input type="checkbox"/>	<input type="checkbox"/>
WOOD	<input checked="" type="checkbox"/>	<input type="checkbox"/>	<input type="checkbox"/>	<input type="checkbox"/>	<input type="checkbox"/>
TILE/COMPO	<input type="checkbox"/>	<input checked="" type="checkbox"/>	<input type="checkbox"/>	<input type="checkbox"/>	<input type="checkbox"/>
CARPET	<input checked="" type="checkbox"/>	<input checked="" type="checkbox"/>	<input type="checkbox"/>	<input type="checkbox"/>	<input type="checkbox"/>

INT. FINISH B 1 2 3 U
 PLASTER/DW
 PANELING
 UNFINISHED

PLUMBING #	10		12,100
GARAGES & CARPORTS			37,200
EXTRA FEATURES			9,600
SUBTOTAL			384,610
GRADE FACTOR			120 %
UNADJUSTED VALUE			461,530
FACTOR			100 %

ACCOMMODATIONS
 # OF ROOMS 3 5
 BEDROOMS 1 2
 FIREPLACES 1
 HEAT & AC B 1 2 3 U

ACCOMMODATIONS	B	1	2	3	U
# OF ROOMS	3	5			
BEDROOMS	1	2			
FIREPLACES	1				
HEAT & AC	<input type="checkbox"/>	<input type="checkbox"/>	<input type="checkbox"/>	<input type="checkbox"/>	<input type="checkbox"/>

NO HEAT
 CTRL HEAT
 HW/STEAM
 ELECTRIC
 HEAT PUMP
 FLR/WALL
 STVE/SPCE
 GEOTHERMAL
 OUTSIDE
 CTRL A/C

OCCUPANCY	ST.HT	SIZE	AREA	GRADE	PRICE	AGE	REMD	CND	UNADJ VAL	PHYS	PHYS VAL	FUNC	TRUE VAL
DWELLING	1	SK	2,313	B		2016		G	461,530	4	443,070		420,900
1 Shed		12x20	240	C	7.70	2021		A	1,850	2	1,810		1,800
2													
3													
4													
5													
6													
7													
8													
9													
10													
11													

PLUMBING BASE
 X FULL BATH 1 1
 X HALF BATH 1
 X FIXTURES 2

PLUMBING #	10		12,100
GARAGES & CARPORTS			37,200
EXTRA FEATURES			9,600
SUBTOTAL			384,610
GRADE FACTOR			120 %
UNADJUSTED VALUE			461,530
FACTOR			100 %

26-083000.0000

TOTAL 422,700

COMMENTS

Dwelling has an Economic Factor of 95% (Rollback Basis=\$532,200)

26-083000.0000

MCEVOY MICHAEL & AMANDA

MCEVOY MICHAEL & AMANDA
4506 BUCKEYE DR
SAINT MARYS, OH 45885

LEGAL INFORMATION

SANDY BEACH SECTION J
LOTS 8-19
RTS: 003-06-01

	OWNERSHIP	ADDRESS	CITY	STATE	ZIP	DATE	AMOUNT	DEED:CONV#	JS	VALID
1	VANTREES GREGORY F &	9833 ST RTE 49	ROCKFORD	OH	45882	04/13/2007	0	QCE : X : 0	<input type="checkbox"/>	<input type="checkbox"/>
2	VANTREES GREGOR R & VICKI	6656 E 700 SOUTH	BERNE	IN	46711	06/28/2005	50,000	WDC : A-M : 0	<input type="checkbox"/>	<input type="checkbox"/>
3	GOETTEMOELLER ERIC J &	119 JOHNSON AVE	CELINA	OH	45822	04/28/1999	31,000	: A-M : 0	<input type="checkbox"/>	<input type="checkbox"/>

X: TTO LISTER: HK DATE: 02/22/2022 TIME: 12:00:00 AM LETTER LETTER REC'D GIS CODE

STREET/ROAD	TOPOGRAPHY	PU-UTILITIES-PR	NEIGHBORHOOD	INFLUENCE FACTORS	PROPERTY LOCATION
<input type="checkbox"/> PAVED	<input checked="" type="checkbox"/> LEVEL	<input type="checkbox"/> WATER <input type="checkbox"/>	<input type="checkbox"/> IMPROVING	<input type="checkbox"/> A. NO ROAD <input type="checkbox"/> F. RESTRICT	4506 BUCKEYE DR
<input type="checkbox"/> GRAVEL	<input type="checkbox"/> HIGH	<input type="checkbox"/> SEWER <input type="checkbox"/>	<input type="checkbox"/> STATIC	<input type="checkbox"/> B. TOPGRHY <input type="checkbox"/> G. WOOD LT	COMMENT
<input type="checkbox"/> DIRT	<input type="checkbox"/> LOW	<input type="checkbox"/> GAS <input type="checkbox"/>	<input type="checkbox"/> DECLINING	<input type="checkbox"/> C. Ex Front <input type="checkbox"/> H. VACANCY	
<input type="checkbox"/> SIDEWALKS	<input type="checkbox"/> ROLLING	<input checked="" type="checkbox"/> ELECTRIC <input type="checkbox"/>	<input type="checkbox"/> OLD	<input type="checkbox"/> D. QUANTITY <input type="checkbox"/> I. WATER FRONT	
<input type="checkbox"/> CURBS	<input type="checkbox"/> STANDARD	<input type="checkbox"/> STANDARD <input type="checkbox"/>	<input type="checkbox"/> STANDARD	<input type="checkbox"/> E. SZ/SHAPE <input type="checkbox"/> J. OTHER/CDU	

LAND COMPUTATIONS

LAND TYPE	SIZE	M	RATE	C	INF	M	VALUE	C
TOTAL						111,300	0	

VALUATION SUMMARY

VALUE YEAR	REASON FOR CHANGE	APPRaised	IMPR	TOTAL	ASSESSED	IMPR	TOTAL

OCCUPANCY		EXTERIOR		FLOOR	AREA	CONST	VALUE
<input type="checkbox"/> SF	<input type="checkbox"/> DU	<input type="checkbox"/> TR	<input type="checkbox"/> WOOD				
<input type="checkbox"/> CONVERSION			<input type="checkbox"/> STUCCO				
BUILDING TYPE			<input type="checkbox"/> ALM/VYNL				
<input type="checkbox"/> MOBILE HOME	<input type="checkbox"/> CONC BLK		<input type="checkbox"/> METAL				
<input type="checkbox"/> BI/TR LEVEL	<input type="checkbox"/> BRICK		<input type="checkbox"/> STONE				
<input type="checkbox"/> MOD/MAN							
<input type="checkbox"/>							

ROOFING		ROOF TYPE				
<input type="checkbox"/> METAL	<input type="checkbox"/> GABLE					
<input type="checkbox"/> SLT/TLE	<input type="checkbox"/> HIP					
<input type="checkbox"/> SHINGLES	<input type="checkbox"/> GAMBREL					
<input type="checkbox"/> SHAKES	<input type="checkbox"/> MANSARD					
<input type="checkbox"/> COMPOSITE	<input type="checkbox"/> FLAT					
FLOORS		B	1	2	3	U
CONCRETE	<input type="checkbox"/>	<input type="checkbox"/>	<input type="checkbox"/>	<input type="checkbox"/>	<input type="checkbox"/>	<input type="checkbox"/>
WOOD	<input type="checkbox"/>	<input type="checkbox"/>	<input type="checkbox"/>	<input type="checkbox"/>	<input type="checkbox"/>	<input type="checkbox"/>
TILE/COMPO	<input type="checkbox"/>	<input type="checkbox"/>	<input type="checkbox"/>	<input type="checkbox"/>	<input type="checkbox"/>	<input type="checkbox"/>
CARPET	<input type="checkbox"/>	<input type="checkbox"/>	<input type="checkbox"/>	<input type="checkbox"/>	<input type="checkbox"/>	<input type="checkbox"/>
INT. FINISH		B	1	2	3	U
PLASTER/DW	<input type="checkbox"/>	<input type="checkbox"/>	<input type="checkbox"/>	<input type="checkbox"/>	<input type="checkbox"/>	<input type="checkbox"/>
PANELING	<input type="checkbox"/>	<input type="checkbox"/>	<input type="checkbox"/>	<input type="checkbox"/>	<input type="checkbox"/>	<input type="checkbox"/>
UNFINISHED	<input type="checkbox"/>	<input type="checkbox"/>	<input type="checkbox"/>	<input type="checkbox"/>	<input type="checkbox"/>	<input type="checkbox"/>
ACCOMMODATIONS						
# OF ROOMS						
BEDROOMS						
FIREPLACES						
HEAT & AC		B	1	2	3	U
NO HEAT	<input type="checkbox"/>	<input type="checkbox"/>	<input type="checkbox"/>	<input type="checkbox"/>	<input type="checkbox"/>	<input type="checkbox"/>
CTRL HEAT	<input type="checkbox"/>	<input type="checkbox"/>	<input type="checkbox"/>	<input type="checkbox"/>	<input type="checkbox"/>	<input type="checkbox"/>
HW/STEAM	<input type="checkbox"/>	<input type="checkbox"/>	<input type="checkbox"/>	<input type="checkbox"/>	<input type="checkbox"/>	<input type="checkbox"/>
ELECTRIC	<input type="checkbox"/>	<input type="checkbox"/>	<input type="checkbox"/>	<input type="checkbox"/>	<input type="checkbox"/>	<input type="checkbox"/>
HEAT PUMP	<input type="checkbox"/>	<input type="checkbox"/>	<input type="checkbox"/>	<input type="checkbox"/>	<input type="checkbox"/>	<input type="checkbox"/>
FLR/WALL	<input type="checkbox"/>	<input type="checkbox"/>	<input type="checkbox"/>	<input type="checkbox"/>	<input type="checkbox"/>	<input type="checkbox"/>
STVE/SPCE	<input type="checkbox"/>	<input type="checkbox"/>	<input type="checkbox"/>	<input type="checkbox"/>	<input type="checkbox"/>	<input type="checkbox"/>
GEOHERMAL	<input type="checkbox"/>	<input type="checkbox"/>	<input type="checkbox"/>	<input type="checkbox"/>	<input type="checkbox"/>	<input type="checkbox"/>
OUTSIDE	<input type="checkbox"/>	<input type="checkbox"/>	<input type="checkbox"/>	<input type="checkbox"/>	<input type="checkbox"/>	<input type="checkbox"/>
CTRL A/C	<input type="checkbox"/>	<input type="checkbox"/>	<input type="checkbox"/>	<input type="checkbox"/>	<input type="checkbox"/>	<input type="checkbox"/>
PLUMBING			BASE <input type="checkbox"/>			
X FULL BATH						
X HALF BATH						
X FIXTURES						

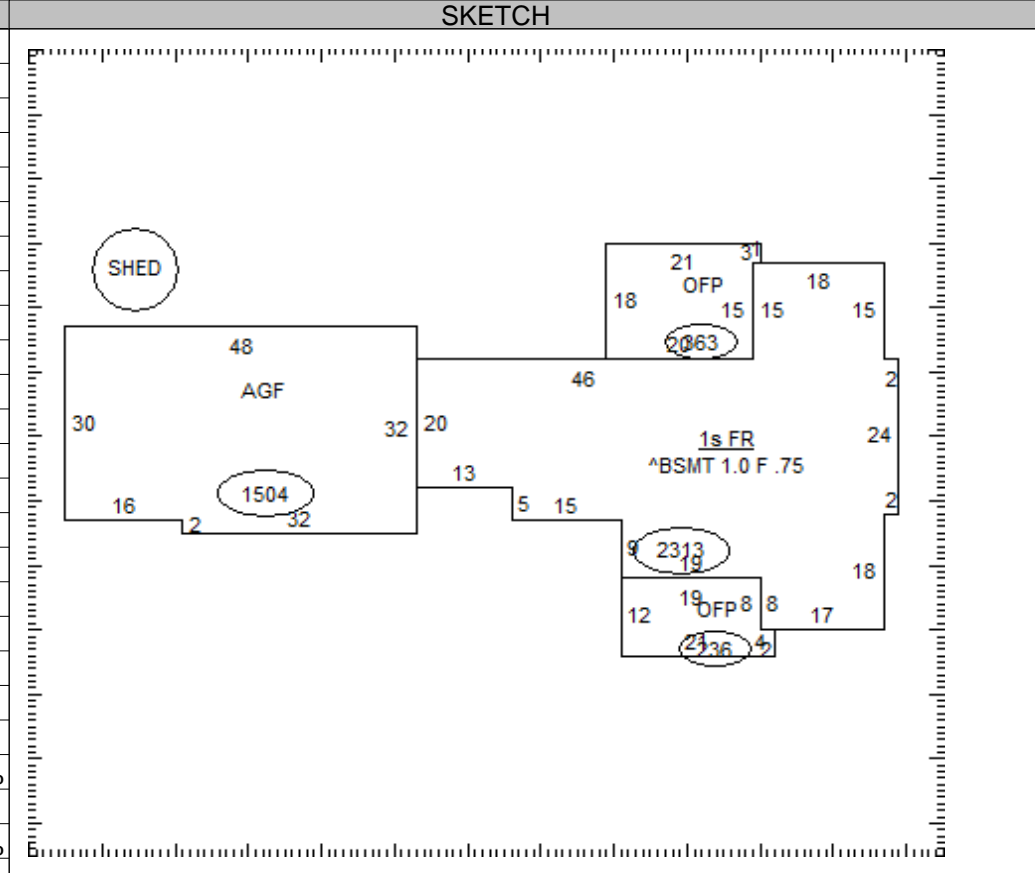

	SUBTOTAL	0											
	MULTI-FAMILY #	0											
	BUILDING TYPE	000%											
	BSMT FINISH	0 S.F.											
	FIREPLACE #	0											
	HEATING	0 S.F.											
	AIR COND	0 S.F.											
	PLUMBING #	0											
	GARAGES & CARPORTS	0											
	EXTRA FEATURES	0											
	SUBTOTAL	0											
	GRADE FACTOR	%											
	UNADJUSTED VALUE	0											
	FACTOR	%											
	SUBTOTAL	0											
	GRADE FACTOR	%											
	UNADJUSTED VALUE	0											
	FACTOR	%											
OCCUPANCY	ST.HT	SIZE	AREA	GRADE	PRICE	AGE	REMD	CND	UNADJ VAL	PHYS	PHYS VAL	FUNC	TRUE VAL
DWELLING		SK											
1													
2													
3													
4													
5													
6													
7													
8													
9													
10													
11													

26-083000.0000 TOTAL 0

COMMENTS