

26-034400.0000

LEGAL INFORMATION

MENCHHOFFER WOODS SUBD #2

RTS: 002-06-04 LOT#: 13

BONILLA ERIK
BONILLA ERIK
4295 WILLIAM AVE
CELINA, OH 45822

	OWNERSHIP	ADDRESS	CITY	STATE	ZIP	DATE	AMOUNT	DEED:CONV#	JS	VALID
1	BONILLA ERIK	4295 WILLIAM AVE	CELINA	OH	45822	06/26/2023	190,000	WDC : 362	<input type="checkbox"/>	<input checked="" type="checkbox"/>
2	REIER JAMIE E	4295 WILLIAM AVE	CELINA	OH	45822	08/04/2015	105,500	WDC : 514	<input type="checkbox"/>	<input checked="" type="checkbox"/>
3	BOROFF PATRICIA	4295 WILLIAM AVE	CELINA	OH	45822	09/29/2005	0	QCE : X : 0	<input type="checkbox"/>	<input type="checkbox"/>

X: TTO LISTER: DA DATE: 03/30/2005 TIME: 12:00:00 AM LETTER LETTER REC'D GIS CODE

STREET/ROAD	TOPOGRAPHY	PU-UTILITIES-PR	NEIGHBORHOOD	INFLUENCE FACTORS	PROPERTY LOCATION	
<input checked="" type="checkbox"/> PAVED <input type="checkbox"/> GRAVEL <input type="checkbox"/> DIRT <input type="checkbox"/> SIDEWALKS <input type="checkbox"/> CURBS	<input checked="" type="checkbox"/> LEVEL <input type="checkbox"/> HIGH <input type="checkbox"/> LOW <input type="checkbox"/> ROLLING <input type="checkbox"/> STANDARD	<input type="checkbox"/> WATER <input type="checkbox"/> SEWER <input type="checkbox"/> GAS <input checked="" type="checkbox"/> ELECTRIC <input type="checkbox"/> STANDARD	<input type="checkbox"/> IMPROVING <input checked="" type="checkbox"/> STATIC <input type="checkbox"/> DECLINING <input type="checkbox"/> OLD <input type="checkbox"/> STANDARD	<input type="checkbox"/> A. NO ROAD <input type="checkbox"/> B. TOPGRHY <input type="checkbox"/> C. Ex Front <input type="checkbox"/> D. QUANTITY <input type="checkbox"/> E. SZ/SHAPE	<input type="checkbox"/> F. RESTRICT <input type="checkbox"/> G. WOOD LT <input type="checkbox"/> H. VACANCY <input type="checkbox"/> I. WATER FRONT <input type="checkbox"/> J. OTHER/CDU	4295 WILLIAM AVE, CELINA COMMENT TY2022:Net Gen=\$1,845.38, Other Assessment=\$2.64 DE16 CORR SIZE OF DWELLING PER RVAL DSKTP REV DE09 PER DATA MAILER ADDED AC,CORR GAR SQ FTG-AERIAL VERIFIED

LAND COMPUTATIONS

LAND TYPE	SIZE	M	RATE	C	INF	M	VALUE	C
F:Front	F100 D200	ST225	DP113	ADJ254			25,400	0
						TOTAL	25,400	0

VALUATION SUMMARY

VALUE YEAR	2023	2020	2017	2017	2017			
REASON FOR CHANGE	RAPP	RAPP	RAPP	MISC	MISC			
APPRAISED VALUE	25,400	23,100	20,300	21,500	21,500			
	IMPR	92,400	82,100	77,100	76,900			
	TOTAL	115,500	102,400	98,600	98,400			
ASSESSED VALUE	8,890	8,090	7,110	7,530	7,530			
	IMPR	32,340	28,740	26,990	26,920			
	TOTAL	40,430	35,850	34,520	34,450			

OCCUPANCY		EXTERIOR		FLOOR	AREA	CONST	VALUE						
<input checked="" type="checkbox"/> SF	<input type="checkbox"/> DU	<input type="checkbox"/> TR	<input type="checkbox"/> WOOD	1	1428	FR	197,250						
<input type="checkbox"/> CONVERSION		<input type="checkbox"/> STUCCO											
BUILDING TYPE		<input checked="" type="checkbox"/> ALM/VYNL											
<input type="checkbox"/> MOBILE HOME		<input type="checkbox"/> CONC BLK											
<input type="checkbox"/> BI/TR LEVEL		<input type="checkbox"/> METAL											
<input type="checkbox"/> MOD/MAN		<input checked="" type="checkbox"/> BRICK											
<input type="checkbox"/> _____		<input type="checkbox"/> STONE											
ROOFING		ROOF TYPE											
<input type="checkbox"/> METAL		<input checked="" type="checkbox"/> GABLE											
<input type="checkbox"/> SLT/TLE		<input type="checkbox"/> HIP											
<input checked="" type="checkbox"/> SHINGLES		<input type="checkbox"/> GAMBREL											
<input type="checkbox"/> SHAKES		<input type="checkbox"/> MANSARD											
<input type="checkbox"/> COMPOSITE		<input type="checkbox"/> FLAT											
FLOORS		B	1	2	3	U							
CONCRETE		<input type="checkbox"/>	<input type="checkbox"/>	<input type="checkbox"/>	<input type="checkbox"/>	<input type="checkbox"/>							
WOOD		<input type="checkbox"/>	<input type="checkbox"/>	<input type="checkbox"/>	<input type="checkbox"/>	<input type="checkbox"/>							
TILE/COMPO		<input type="checkbox"/>	<input checked="" type="checkbox"/>	<input type="checkbox"/>	<input type="checkbox"/>	<input type="checkbox"/>							
CARPET		<input type="checkbox"/>	<input checked="" type="checkbox"/>	<input type="checkbox"/>	<input type="checkbox"/>	<input type="checkbox"/>							
INT. FINISH		B	1	2	3	U							
PLASTER/DW		<input type="checkbox"/>	<input checked="" type="checkbox"/>	<input type="checkbox"/>	<input type="checkbox"/>	<input type="checkbox"/>							
PANELING		<input type="checkbox"/>	<input type="checkbox"/>	<input type="checkbox"/>	<input type="checkbox"/>	<input type="checkbox"/>							
UNFINISHED		<input type="checkbox"/>	<input type="checkbox"/>	<input type="checkbox"/>	<input type="checkbox"/>	<input type="checkbox"/>							
ACCOMMODATIONS													
# OF ROOMS			7										
BEDROOMS			3										
FIREPLACES			1										
HEAT & AC		B	1	2	3	U							
NO HEAT		<input type="checkbox"/>	<input type="checkbox"/>	<input type="checkbox"/>	<input type="checkbox"/>	<input type="checkbox"/>							
CTRL HEAT		<input type="checkbox"/>	<input checked="" type="checkbox"/>	<input type="checkbox"/>	<input type="checkbox"/>	<input type="checkbox"/>							
HW/STEAM		<input type="checkbox"/>	<input type="checkbox"/>	<input type="checkbox"/>	<input type="checkbox"/>	<input type="checkbox"/>							
ELECTRIC		<input type="checkbox"/>	<input type="checkbox"/>	<input type="checkbox"/>	<input type="checkbox"/>	<input type="checkbox"/>							
HEAT PUMP		<input type="checkbox"/>	<input type="checkbox"/>	<input type="checkbox"/>	<input type="checkbox"/>	<input type="checkbox"/>							
FLR/WALL		<input type="checkbox"/>	<input type="checkbox"/>	<input type="checkbox"/>	<input type="checkbox"/>	<input type="checkbox"/>							
STVE/SPCE		<input type="checkbox"/>	<input type="checkbox"/>	<input type="checkbox"/>	<input type="checkbox"/>	<input type="checkbox"/>							
GEOTHERMAL		<input type="checkbox"/>	<input type="checkbox"/>	<input type="checkbox"/>	<input type="checkbox"/>	<input type="checkbox"/>							
OUTSIDE		<input type="checkbox"/>	<input type="checkbox"/>	<input type="checkbox"/>	<input type="checkbox"/>	<input type="checkbox"/>							
CTRL A/C		<input type="checkbox"/>	<input checked="" type="checkbox"/>	<input type="checkbox"/>	<input type="checkbox"/>	<input type="checkbox"/>							
PLUMBING		BASE		<input checked="" type="checkbox"/>									
X FULL BATH													
X HALF BATH													
X FIXTURES													
SUBTOTAL						197,250							
MULTI-FAMILY #		0				0							
BUILDING TYPE		100%				0							
BSMT FINISH		0 S.F.				0							
FIREPLACE #		1				4,400							
HEATING		0 S.F.				0							
AIR COND		1,428 S.F.				2,360							
PLUMBING #		0				0							
GARAGES & CARPORTS						16,600							
EXTRA FEATURES						4,400							
SUBTOTAL						225,010							
GRADE FACTOR						100 %							
UNADJUSTED VALUE						225,010							
FACTOR						100 %							
OCCUPANCY	ST.HT	SIZE	AREA	GRADE	PRICE	AGE	REMD	CND	UNADJ VAL	PHYS	PHYS VAL	FUNC	TRUE VAL
DWELLING	1	SK	1,428	C		1969		A	225,010	40	135,010		128,300
1 Shed	PP	10x12	120	C		2000		A		37			0
2													
3													
4													
5													
6													
7													
8													
9													
10													
11													
TOTAL											128,300		

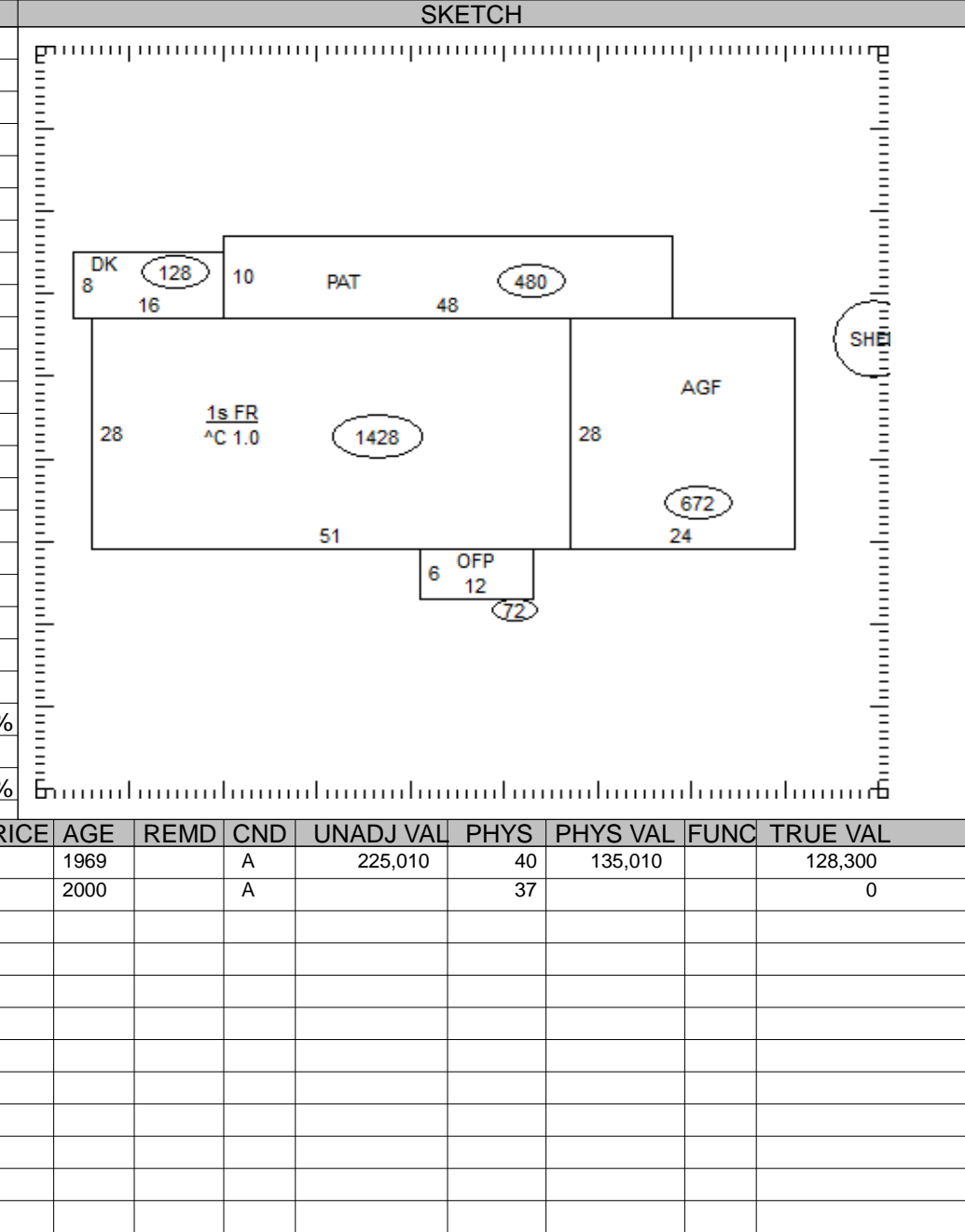

26-034400.0000

TOTAL 128,300

COMMENTS

Dwelling has an Economic Factor of 95%

Property Class: 510

Neighborhood
002604-RS50

Map: 09A

Block:

Card: 42

Bk: Pg:

JEFFERSON TWP / CELINA SD

08-04-253-007

26-034400.0000

LEGAL INFORMATION
MENCHHOFER WOODS SUBD #2

RTS: 002-06-04 LOT#: 13

BONILLA ERIK
BONILLA ERIK
4295 WILLIAM AVE
CELINA, OH 45822

OWNERSHIP	ADDRESS	CITY	STATE	ZIP	DATE	AMOUNT	DEED:CONV#	JS	VALID
1	SNYDER LEE ANN	4295 WILLIAM AVE	CELINA	OH 45822	06/17/1987	0	: X : 0	<input type="checkbox"/>	<input type="checkbox"/>
2						0	0	<input type="checkbox"/>	<input type="checkbox"/>
3						0	0	<input type="checkbox"/>	<input type="checkbox"/>

X: TTO LISTER: DA DATE: 03/30/2005 TIME: 12:00:00 AM LETTER LETTER REC'D GIS CODE

STREET/ROAD	TOPOGRAPHY	PU-UTILITIES-PR	NEIGHBORHOOD	INFLUENCE FACTORS	PROPERTY LOCATION	
<input checked="" type="checkbox"/> PAVED <input type="checkbox"/> GRAVEL <input type="checkbox"/> DIRT <input type="checkbox"/> SIDEWALKS <input type="checkbox"/> CURBS	<input checked="" type="checkbox"/> LEVEL <input type="checkbox"/> HIGH <input type="checkbox"/> LOW <input type="checkbox"/> ROLLING <input type="checkbox"/> STANDARD	<input type="checkbox"/> WATER <input type="checkbox"/> SEWER <input type="checkbox"/> GAS <input checked="" type="checkbox"/> ELECTRIC <input type="checkbox"/> STANDARD	<input type="checkbox"/> IMPROVING <input checked="" type="checkbox"/> STATIC <input type="checkbox"/> DECLINING <input type="checkbox"/> OLD <input type="checkbox"/> STANDARD	<input type="checkbox"/> A. NO ROAD <input type="checkbox"/> B. TOPGRHY <input type="checkbox"/> C. Ex Front <input type="checkbox"/> D. QUANTITY <input type="checkbox"/> E. SZ/SHAPE	<input type="checkbox"/> F. RESTRICT <input type="checkbox"/> G. WOOD LT <input type="checkbox"/> H. VACANCY <input type="checkbox"/> I. WATER FRONT <input type="checkbox"/> J. OTHER/CDU	4295 WILLIAM AVE, CELINA COMMENT

LAND COMPUTATIONS							
LAND TYPE	SIZE	M	RATE	C	INF	M	VALUE C
TOTAL						25,400	0

VALUATION SUMMARY

VALUE YEAR	REASON FOR CHANGE	APPRaised	IMPR	TOTAL	ASSESSED	IMPR	TOTAL

OCCUPANCY	EXTERIOR	FLOOR	AREA	CONST	VALUE
<input type="checkbox"/> SF <input type="checkbox"/> DU <input type="checkbox"/> TR	<input type="checkbox"/> WOOD				
<input type="checkbox"/> CONVERSION	<input type="checkbox"/> STUCCO				
BUILDING TYPE	<input type="checkbox"/> ALM/VYNL				
<input type="checkbox"/> MOBILE HOME	<input type="checkbox"/> CONC BLK				
<input type="checkbox"/> BI/TR LEVEL	<input type="checkbox"/> METAL				
<input type="checkbox"/> MOD/MAN	<input type="checkbox"/> BRICK				
<input type="checkbox"/>	<input type="checkbox"/> STONE				
ROOFING	ROOF TYPE				
<input type="checkbox"/> METAL	<input type="checkbox"/> GABLE				
<input type="checkbox"/> SLT/TLE	<input type="checkbox"/> HIP				
<input type="checkbox"/> SHINGLES	<input type="checkbox"/> GAMBREL				
<input type="checkbox"/> SHAKES	<input type="checkbox"/> MANSARD				
<input type="checkbox"/> COMPOSITE	<input type="checkbox"/> FLAT				

SUBTOTAL			0
MULTI-FAMILY #	0		0
BUILDING TYPE	000%		0
BSMT FINISH	0 S.F.		0
FIREPLACE #	0		0
HEATING	0 S.F.		0
AIR COND	0 S.F.		0
PLUMBING #	0		0
GARAGES & CARPORTS			0
EXTRA FEATURES			0
SUBTOTAL			0
GRADE FACTOR			%
UNADJUSTED VALUE			0
FACTOR			%

ACCOMMODATIONS		B	1	2	3	U
# OF ROOMS						
BEDROOMS						
FIREPLACES						
HEAT & AC		B	1	2	3	U
NO HEAT		<input type="checkbox"/>	<input type="checkbox"/>	<input type="checkbox"/>	<input type="checkbox"/>	<input type="checkbox"/>
CTRL HEAT		<input type="checkbox"/>	<input type="checkbox"/>	<input type="checkbox"/>	<input type="checkbox"/>	<input type="checkbox"/>
HW/STEAM		<input type="checkbox"/>	<input type="checkbox"/>	<input type="checkbox"/>	<input type="checkbox"/>	<input type="checkbox"/>
ELECTRIC		<input type="checkbox"/>	<input type="checkbox"/>	<input type="checkbox"/>	<input type="checkbox"/>	<input type="checkbox"/>
HEAT PUMP		<input type="checkbox"/>	<input type="checkbox"/>	<input type="checkbox"/>	<input type="checkbox"/>	<input type="checkbox"/>
FLR/WALL		<input type="checkbox"/>	<input type="checkbox"/>	<input type="checkbox"/>	<input type="checkbox"/>	<input type="checkbox"/>
STVE/SPCE		<input type="checkbox"/>	<input type="checkbox"/>	<input type="checkbox"/>	<input type="checkbox"/>	<input type="checkbox"/>
GEO THERMAL		<input type="checkbox"/>	<input type="checkbox"/>	<input type="checkbox"/>	<input type="checkbox"/>	<input type="checkbox"/>
OUTSIDE		<input type="checkbox"/>	<input type="checkbox"/>	<input type="checkbox"/>	<input type="checkbox"/>	<input type="checkbox"/>
CTRL A/C		<input type="checkbox"/>	<input type="checkbox"/>	<input type="checkbox"/>	<input type="checkbox"/>	<input type="checkbox"/>
PLUMBING						BASE <input type="checkbox"/>
X FULL BATH						
X HALF BATH						
X FIXTURES						

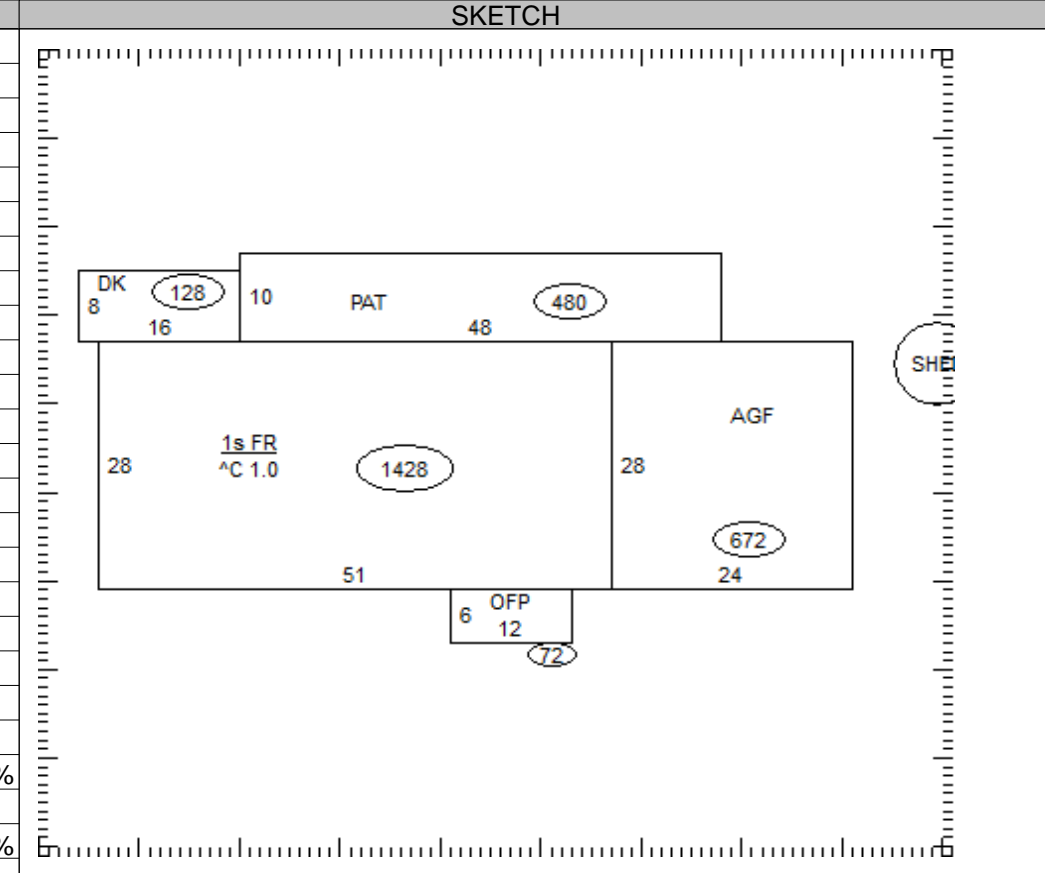

OCCUPANCY	ST.HT	SIZE	AREA	GRADE	PRICE	AGE	REMD	CND	UNADJ VAL	PHYS	PHYS VAL	FUNC	TRUE VAL
DWELLING		SK											
1													
2													
3													
4													
5													
6													
7													
8													
9													
10													
11													

26-034400.0000

TOTAL 0

COMMENTS