

Property Address: 5150 ST RTE 29

DTE Code: 499



\*26-027300.0100\*

JEFFERSON TWP  
CELINA SD  
08-02-300-008

Created in 2006 From 26-027300.0000 due to Split

**LEGAL INFORMATION**

PT E 1/2 SW

Acres:3.8890

RTS: 002-06-02  
**MORE HOUSE LLC**  
MORE HOUSE LLC  
5150 ST RTE 29  
CELINA, OH 45822

Neighborhood CRUR26
Map: 10
Block:
Card: 10
Bk: Pg:

COMMENT  
TY2022:Net Gen=\$4,730.56, Other Assessment=\$0.00  
DE17 DESKTOP RVW CHGS: ADJ PRICING  
Corrective Address of 1390 for the Commercial Building and 1400 for the house to be used upon transfer of land.  
DE23 ADD SHELTER, CHG GRD TO AVG, CHG FL TO 2; DESKTOP RVW

Sales Data						Date
Date	Amount	Deed:Conv#	Use	Valid	Lister:	02/16/23
12/28/2020	314,500		WDC : 975	499	<input checked="" type="checkbox"/>	Pricer:
09/29/2020	0		QCE : X : 0	499	<input type="checkbox"/>	Reviewer:
09/20/2006	0		: 0	499	<input type="checkbox"/>	Final:
					<input type="checkbox"/>	Call Back:
					<input type="checkbox"/>	Visit:

VALUATION SUMMARY				
VALUE YEAR	2023	2020	2017	2017
REASON FOR CHANGE	RAPP	RAPP	RAPP	MISC
ESTIMATED	48,220	28,820	28,820	26,290
MARKET VALUE	IMPR	288,190	218,340	226,920
	TOTAL	336,410	247,160	255,740
ASSESSED	LAND	16,880	10,090	10,090
VALUE	IMPR	100,870	76,420	79,420
	TOTAL	117,750	86,510	89,510
				93,800

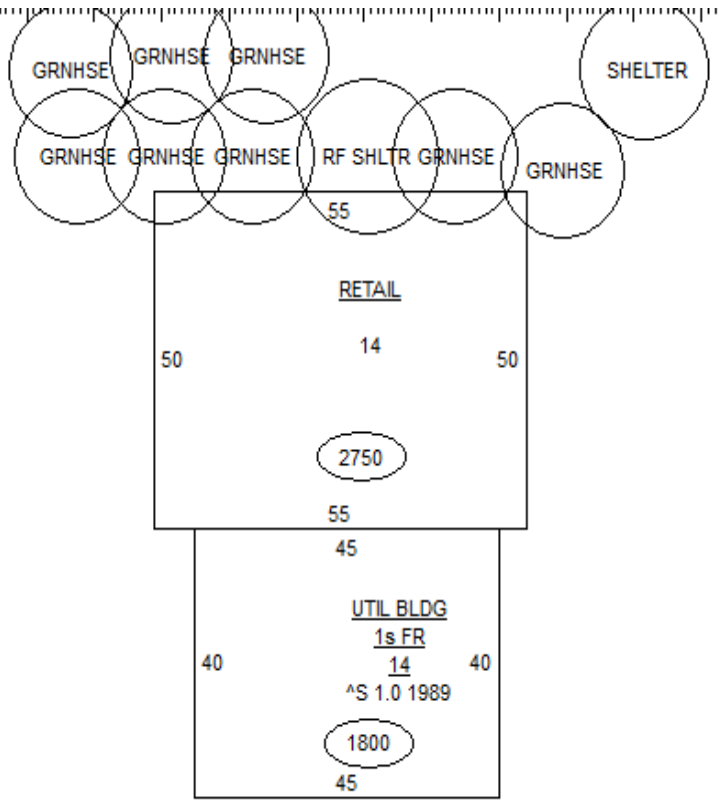

STREET/ROAD	TOPOGRAPHY	PU-UTILITIES-PR	ZONING
<input type="checkbox"/> PAVED	<input type="checkbox"/> LEVEL	<input type="checkbox"/> WATER	<input type="checkbox"/> AG-RES
<input type="checkbox"/> GRAVEL	<input type="checkbox"/> HIGH	<input type="checkbox"/> SEWER	<input type="checkbox"/> COMMERCIAL
<input type="checkbox"/> DIRT	<input type="checkbox"/> LOW	<input type="checkbox"/> GAS	<input type="checkbox"/> INDUSTRIAL
<input type="checkbox"/> SIDEWALKS	<input type="checkbox"/> ROLLING	<input type="checkbox"/> ELECTRIC	
<input type="checkbox"/> CURBS	<input type="checkbox"/> STANDARD	<input type="checkbox"/> STANDARD	

INFLUENCE FACTORS		
A. NO ROAD	E. SZ/SHAPE	I. WATER FRONT
B. TOPGRHY	F. RESTRICT	J. OTHER/CDU
C. Ex Front	G. WOOD LT	
D. QUANTITY	H. VACANCY	

LAND TYPE	SIZE	M	RATE	C	INF	M	VALUE	C
1:Primary	A:3.889		20,000				48,220	0
Totals:	Total Acres 3.8890						48,220	0





\*26-027300.0100\*

JEFFERSON TWP  
 CELINA SD  
 08-02-300-008

Created in 2006 From 26-027300.0000 due to Split

**LEGAL INFORMATION**

PT E 1/2 SW

Acres:3.8890

RTS: 002-06-02  
**MORE HOUSE LLC**  
 MORE HOUSE LLC  
 5150 ST RTE 29  
 CELINA, OH 45822  
 COMMENT

Neighborhood CRUR26
Map: 10
Block:
Card: 10
Bk: Pg:

Sales Data						Date
Date	Amount	Deed:Conv#	Use	Valid	Lister:	02/16/23
12/28/2020	314,500		WDC : 975	499	<input checked="" type="checkbox"/>	Pricer:
09/29/2020	0		QCE : X : 0	499	<input type="checkbox"/>	Reviewer:
09/20/2006	0		: 0	499	<input type="checkbox"/>	Final:
					<input type="checkbox"/>	Call Back:
					<input type="checkbox"/>	Visit:

VALUATION SUMMARY			
VALUE YEAR	2017	2017	2017
REASON FOR CHANGE	MISC	MISC	MISC
ESTIMATED	26,290	41,020	30,330
MARKET VALUE	230,170	230,170	230,170
	<u>TOTAL</u>	256,460	271,190
ASSESSED	9,200	14,360	10,620
VALUE	80,560	80,560	80,560
	<u>TOTAL</u>	89,760	94,920

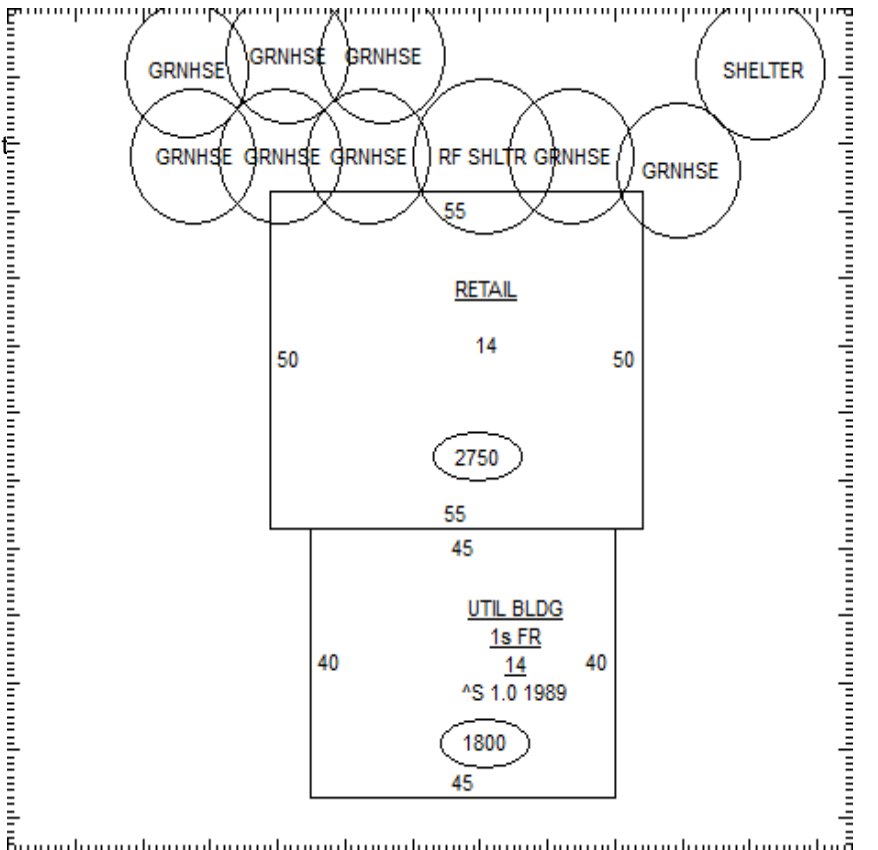

STREET/ROAD	TOPOGRAPHY	PU-UTILITIES-PR	ZONING
<input type="checkbox"/> PAVED	<input type="checkbox"/> LEVEL	<input type="checkbox"/> WATER	<input type="checkbox"/> AG-RES
<input type="checkbox"/> GRAVEL	<input type="checkbox"/> HIGH	<input type="checkbox"/> SEWER	<input type="checkbox"/> COMMERCIAL
<input type="checkbox"/> DIRT	<input type="checkbox"/> LOW	<input type="checkbox"/> GAS	<input type="checkbox"/> INDUSTRIAL
<input type="checkbox"/> SIDEWALKS	<input type="checkbox"/> ROLLING	<input type="checkbox"/> ELECTRIC	
<input type="checkbox"/> CURBS	<input type="checkbox"/> STANDARD	<input type="checkbox"/> STANDARD	

INFLUENCE FACTORS		
A. NO ROAD	E. SZ/SHAPE	I. WATER FRONT
B. TOPGRHY	F. RESTRICT	J. OTHER/CDU
C. Ex Front	G. WOOD LT	
D. QUANTITY	H. VACANCY	

LAND TYPE	SIZE	M	RATE	C	INF	M	VALUE	C
Totals:	Total Acres 3.8890					48,220	0	48,220

