

26-025700.0101

**LEGAL INFORMATION**

PT SE NW

RTS: 002-06-02  
Acres:1.6000

**MUHLENKAMP RYAN W & CARA E**

MUHLENKAMP RYAN W & CARA E

5221 STATE ROUTE 29

CELINA, OH 45822

Created in 2015 From 26-025700.0100 due to Split

OWNERSHIP	ADDRESS	CITY	STATE	ZIP	DATE	AMOUNT	DEED:CONV#	JS	VALID
1	MUHLENKAMP RYAN W &	5221 STATE ROUTE 29	CELINA	OH	45822	09/04/2015	160,000	WDC : 599	<input type="checkbox"/> <input checked="" type="checkbox"/>
2							0	0	<input type="checkbox"/> <input type="checkbox"/>
3							0	0	<input type="checkbox"/> <input type="checkbox"/>

X:  TTO LISTER: DATE: TIME:  LETTER  LETTER REC'D GIS CODE MINOR SUB

**STREET/ROAD TOPOGRAPHY PU-UTILITIES-PR NEIGHBORHOOD INFLUENCE FACTORS PROPERTY LOCATION**

PAVED  LEVEL  WATER  IMPROVING  A. NO ROAD  F. RESTRICT  
 GRAVEL  HIGH  SEWER  STATIC  B. TOPGRHY  G. WOOD LT  
 DIRT  LOW  GAS  DECLINING  C. Ex Front  H. VACANCY  
 SIDEWALKS  ROLLING  ELECTRIC  OLD  D. QUANTITY  I. WATER FRONT  
 CURBS  STANDARD  STANDARD  E. SZ/SHAPE  J. OTHER/CDU

5221 STATE ROUTE 29  
**COMMENT**  
 TY2022:Net Gen=\$3,230.30, Other  
 Assessment=\$2.88  
 DE22 CHG DET GAR TO CABIN, ADD PB;  
 DESKTOP RVW

**LAND COMPUTATIONS**

LAND TYPE	SIZE	M	RATE	C	INF	M	VALUE	C
HS:Home Site	AC:1	25440				25,400	0	
SM:Small Acreage	AC:0.6	8500				5,100	0	
Total Acres: 1.6000					TOTAL	30,500	0	

**VALUATION SUMMARY**

VALUE YEAR	2023	2022	2020	2017				
REASON FOR CHANGE	RAPP	NC	RAPP	RAPP				
APPRAISED VALUE	<u>LAND</u>	30,500	25,200	25,200	20,700			
	<u>IMPR</u>	238,300	176,400	158,200	123,700			
	<u>TOTAL</u>	268,800	201,600	183,400	144,400			
ASSESSED VALUE	<u>LAND</u>	10,680	8,820	8,820	7,250			
	<u>IMPR</u>	83,410	61,740	55,370	43,300			
	<u>TOTAL</u>	94,090	70,560	64,190	50,550			

OCCUPANCY	EXTERIOR	FLOOR	AREA	CONST	VALUE
<input checked="" type="checkbox"/> SF <input type="checkbox"/> DU <input type="checkbox"/> TR	<input checked="" type="checkbox"/> WOOD	1	1591	BRK	214,040
<input type="checkbox"/> CONVERSION	<input type="checkbox"/> STUCCO	1	140	FR	17,600
<b>BUILDING TYPE</b>	<input type="checkbox"/> ALM/VYNL	.25	120	BRK	14,720
<input type="checkbox"/> MOBILE HOME	<input type="checkbox"/> CONC BLK	.5	556	BRK	46,340
<input type="checkbox"/> BI/TR LEVEL	<input type="checkbox"/> METAL				
<input type="checkbox"/> MOD/MAN	<input checked="" type="checkbox"/> BRICK				
<input type="checkbox"/>	<input type="checkbox"/> STONE				

ROOFING	ROOF TYPE
<input type="checkbox"/> METAL	<input checked="" type="checkbox"/> GABLE
<input type="checkbox"/> SLT/TLE	<input type="checkbox"/> HIP
<input checked="" type="checkbox"/> SHINGLES	<input type="checkbox"/> GAMBREL
<input type="checkbox"/> SHAKES	<input type="checkbox"/> MANSARD
<input type="checkbox"/> COMPOSITE	<input type="checkbox"/> FLAT

FLOORS	B	1	2	3	U
CONCRETE	<input type="checkbox"/>	<input type="checkbox"/>	<input type="checkbox"/>	<input type="checkbox"/>	<input type="checkbox"/>
WOOD	<input type="checkbox"/>	<input checked="" type="checkbox"/>	<input type="checkbox"/>	<input checked="" type="checkbox"/>	<input type="checkbox"/>
TILE/COMPO	<input type="checkbox"/>	<input type="checkbox"/>	<input type="checkbox"/>	<input type="checkbox"/>	<input type="checkbox"/>
CARPET	<input type="checkbox"/>	<input checked="" type="checkbox"/>	<input checked="" type="checkbox"/>	<input type="checkbox"/>	<input checked="" type="checkbox"/>

INT. FINISH	B	1	2	3	U
PLASTER/DW	<input type="checkbox"/>	<input checked="" type="checkbox"/>	<input checked="" type="checkbox"/>	<input checked="" type="checkbox"/>	<input checked="" type="checkbox"/>
PANELING	<input type="checkbox"/>	<input type="checkbox"/>	<input type="checkbox"/>	<input type="checkbox"/>	<input type="checkbox"/>
UNFINISHED	<input checked="" type="checkbox"/>	<input type="checkbox"/>	<input type="checkbox"/>	<input type="checkbox"/>	<input type="checkbox"/>

ACCOMMODATIONS	B	1	2	3	U
# OF ROOMS		6		1	2
BEDROOMS		2			2
FIREPLACES					
HEAT & AC	B	1	2	3	U
NO HEAT	<input type="checkbox"/>	<input type="checkbox"/>	<input type="checkbox"/>	<input type="checkbox"/>	<input type="checkbox"/>
CTRL HEAT	<input type="checkbox"/>	<input checked="" type="checkbox"/>	<input checked="" type="checkbox"/>	<input checked="" type="checkbox"/>	<input checked="" type="checkbox"/>
HW/STEAM	<input type="checkbox"/>	<input type="checkbox"/>	<input type="checkbox"/>	<input type="checkbox"/>	<input type="checkbox"/>
ELECTRIC	<input type="checkbox"/>	<input type="checkbox"/>	<input type="checkbox"/>	<input type="checkbox"/>	<input type="checkbox"/>
HEAT PUMP	<input type="checkbox"/>	<input type="checkbox"/>	<input type="checkbox"/>	<input type="checkbox"/>	<input type="checkbox"/>
FLR/WALL	<input type="checkbox"/>	<input type="checkbox"/>	<input type="checkbox"/>	<input type="checkbox"/>	<input type="checkbox"/>
STVE/SPCE	<input type="checkbox"/>	<input type="checkbox"/>	<input type="checkbox"/>	<input type="checkbox"/>	<input type="checkbox"/>
GEO THERMAL	<input type="checkbox"/>	<input type="checkbox"/>	<input type="checkbox"/>	<input type="checkbox"/>	<input type="checkbox"/>
OUTSIDE	<input type="checkbox"/>	<input type="checkbox"/>	<input type="checkbox"/>	<input type="checkbox"/>	<input type="checkbox"/>
CTRL A/C	<input type="checkbox"/>	<input type="checkbox"/>	<input type="checkbox"/>	<input checked="" type="checkbox"/>	<input checked="" type="checkbox"/>
PLUMBING	BASE	<input checked="" type="checkbox"/>			
X FULL BATH		1			
X HALF BATH					1
X FIXTURES					

BSMT	AREA	VALUE
BSMT	1193	17,060
<b>SUBTOTAL</b>		<b>309,760</b>
MULTI-FAMILY #	0	0
BUILDING TYPE	100%	0
BSMT FINISH	0 S.F.	0
FIREPLACE #	0	0
HEATING	0 S.F.	0
AIR COND	676 S.F.	1,120
PLUMBING #	5	6,050
GARAGES & CARPORTS		13,100
EXTRA FEATURES		5,000
<b>SUBTOTAL</b>		<b>335,030</b>
GRADE FACTOR		105 %
<b>UNADJUSTED VALUE</b>		<b>351,780</b>
FACTOR		100 %

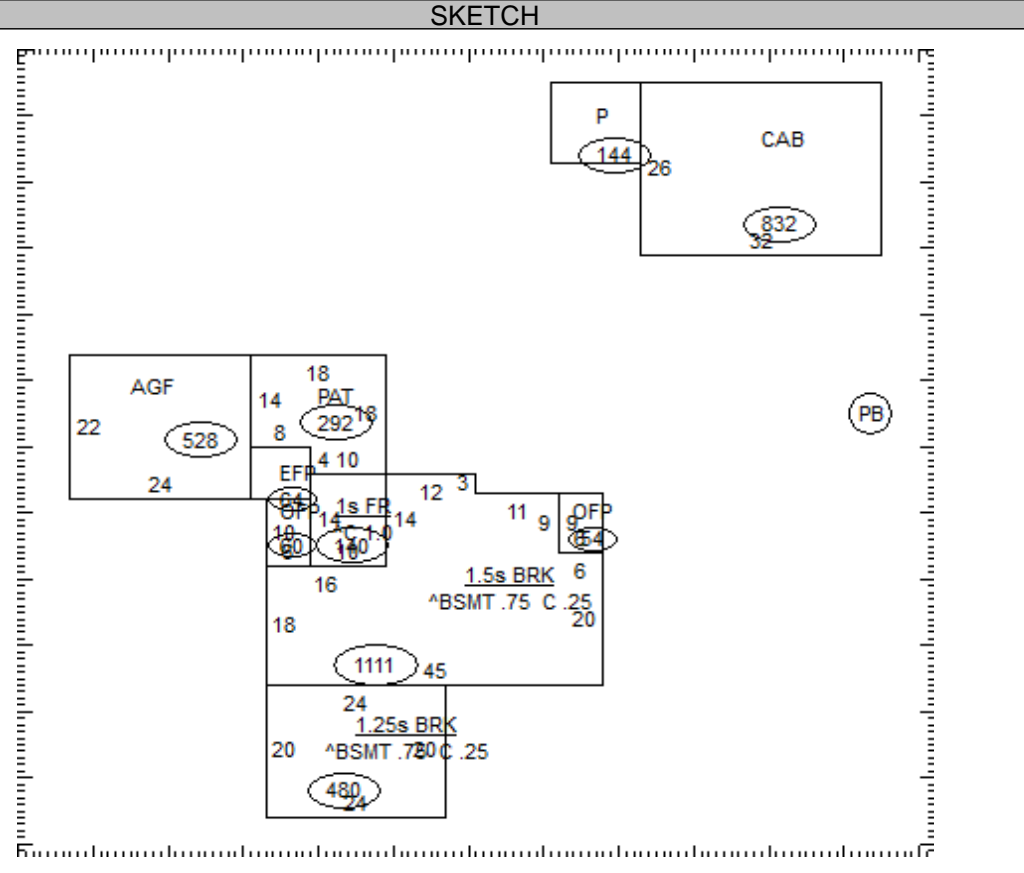

OCCUPANCY	ST.HT	SIZE	AREA	GRADE	PRICE	AGE	REMD	CND	UNADJ VAL	PHYS	PHYS VAL	FUNC	TRUE VAL
DWELLING	1.25	SK	2,407	C+		1930		A	351,780	45	193,480		216,700
1 Patio		12x12	144	C	4.05	1960	2005	A	580	90	60		100
2 Cabin		26x32	832	C	41.25	1960	2005	A	34,320	90	3,430		3,400
3 Pole Bldg	14	32x48	1,536	C	12.16	2020		A	18,680	3	18,120		18,100
4													
5													
6													
7													
8													
9													
10													
11													

26-025700.0101

TOTAL 238,300

**COMMENTS**  
 Dwelling has an Economic Factor of 112% (Rollback Basis=\$242,100)