

Property Class: 510

Neighborhood  
009265-R150

Map: 04

Block:

Card: 05

Bk: Pg:

JEFFERSON TWP / CELINA SD

05-33-400-015

26-012000.1000

**SITES DONALD L JR & MEGAN**  
SITES DONALD L JR & MEGAN  
7143 HELLWARTH RD  
CELINA, OH 45822

**LEGAL INFORMATION**  
E SD E 1/2 SE

RTS: 002-05-33  
Acres:1.2490

	OWNERSHIP	ADDRESS	CITY	STATE	ZIP	DATE	AMOUNT	DEED:CONV#	JS	VALID
1	SITES DONALD L JR & MEGAN	7143 HELLWARTH RD	CELINA	OH	45822	11/05/2021	353,000	WDC : 941	<input type="checkbox"/>	<input checked="" type="checkbox"/>
2	SCHWIETERMAN JASON L &	7143 HELLWARTH RD	CELINA	OH	45822	12/23/2019	329,000	WDC : 880	<input type="checkbox"/>	<input checked="" type="checkbox"/>
3	KREMER TERRENCE E &	7143 HELLWARTH RD	CELINA	OH	45822	12/11/2007	0	QCE : X : 0	<input type="checkbox"/>	<input checked="" type="checkbox"/>

X:  TTO LISTER: HK DATE: 02/03/2020 TIME: 12:00:00 AM  LETTER  LETTER REC'D GIS CODE Minor Sub

STREET/ROAD	TOPOGRAPHY	PU-UTILITIES-PR	NEIGHBORHOOD	INFLUENCE FACTORS				PROPERTY LOCATION			
<input checked="" type="checkbox"/> PAVED	<input checked="" type="checkbox"/> LEVEL	<input type="checkbox"/> WATER	<input type="checkbox"/> IMPROVING	<input type="checkbox"/> A. NO ROAD	<input type="checkbox"/> F. RESTRICT	7143 HELLWARTH RD, CELINA					
<input type="checkbox"/> GRAVEL	<input type="checkbox"/> HIGH	<input type="checkbox"/> SEWER	<input type="checkbox"/> STATIC	<input type="checkbox"/> B. TOPGRHY	<input type="checkbox"/> G. WOOD LT	COMMENT TY2022:Net Gen=\$4,063.02, Other Assessment=\$2.64 DE19 5/27/2019 TORNADO LOSS OF 2 BUILDINGS, 3/4 ROOF GONE AND WATER DAMAGE INSIDE, POOL NEEDS REDONE DE20 REPAIRS COMPL; RMV DET GAR DE21 ADD X-FIXTURE & PARTAL FIN BASEMENT DE22 DESKTOP RVW; ADD SHED W/OPF DE22 RMV OWN OCC - DID NOT RETURN APP					
<input type="checkbox"/> DIRT	<input type="checkbox"/> LOW	<input type="checkbox"/> GAS	<input type="checkbox"/> DECLINING	<input type="checkbox"/> C. Ex Front	<input type="checkbox"/> H. VACANCY						
<input type="checkbox"/> SIDEWALKS	<input type="checkbox"/> ROLLING	<input type="checkbox"/> ELECTRIC	<input type="checkbox"/> OLD	<input type="checkbox"/> D. QUANTITY	<input type="checkbox"/> I. WATER FRONT						
<input type="checkbox"/> CURBS	<input type="checkbox"/> STANDARD	<input checked="" type="checkbox"/> STANDARD	<input type="checkbox"/> STANDARD	<input type="checkbox"/> E. SZ/SHAPE	<input type="checkbox"/> J. OTHER/CDU						
LAND COMPUTATIONS											
LAND TYPE	SIZE	M	RATE	C	INF					M	VALUE
HS:Home Site	AC:1	25440				25,400	0				
SM:Small Acreage	AC:0.249	8500				2,100	0				
Total Acres: 1.2490						TOTAL	27,500	0			

VALUATION SUMMARY									
VALUE YEAR	2023	2022	2021	2021	2020	2020	2019	2019	
REASON FOR CHANGE	RAPP	MISC	MISC	MISC	RAPP	NC	REMB	REMB	
APPRAISED	LAND	27,500	22,200	22,200	22,200	22,200	18,200	18,200	18,200
VALUE	IMPR	325,000	226,600	225,600	224,300	218,800	180,300	112,900	181,900
	TOTAL	352,500	248,800	247,800	246,500	241,000	198,500	131,100	200,100
ASSESSED	LAND	9,630	7,770	7,770	7,770	7,770	6,370	6,370	6,370
VALUE	IMPR	113,750	79,310	78,960	78,510	76,580	63,110	39,520	63,670
	TOTAL	123,380	87,080	86,730	86,280	84,350	69,480	45,890	70,040

OCCUPANCY	EXTERIOR	FLOOR	AREA	CONST	VALUE
<input checked="" type="checkbox"/> SF <input type="checkbox"/> DU <input type="checkbox"/> TR	<input type="checkbox"/> WOOD	1	1416	FR	195,590
<input type="checkbox"/> CONVERSION	<input type="checkbox"/> STUCCO	2ND	720	FR	47,740
<b>BUILDING TYPE</b>	<input checked="" type="checkbox"/> ALM/VYNL				
<input type="checkbox"/> MOBILE HOME	<input type="checkbox"/> CONC BLK				
<input type="checkbox"/> BI/TR LEVEL	<input type="checkbox"/> METAL				
<input type="checkbox"/> MOD/MAN	<input type="checkbox"/> BRICK				
<input type="checkbox"/>	<input type="checkbox"/> STONE				

ROOFING	ROOF TYPE
<input type="checkbox"/> METAL	<input checked="" type="checkbox"/> GABLE
<input type="checkbox"/> SLT/TLE	<input type="checkbox"/> HIP
<input checked="" type="checkbox"/> SHINGLES	<input type="checkbox"/> GAMBREL
<input type="checkbox"/> SHAKES	<input type="checkbox"/> MANSARD
<input type="checkbox"/> COMPOSITE	<input type="checkbox"/> FLAT

FLOORS	B	1	2	3	U
CONCRETE	<input checked="" type="checkbox"/>	<input type="checkbox"/>	<input type="checkbox"/>	<input type="checkbox"/>	<input type="checkbox"/>
WOOD	<input type="checkbox"/>	<input type="checkbox"/>	<input type="checkbox"/>	<input type="checkbox"/>	<input type="checkbox"/>
TILE/COMPO	<input type="checkbox"/>	<input checked="" type="checkbox"/>	<input checked="" type="checkbox"/>	<input type="checkbox"/>	<input type="checkbox"/>
CARPET	<input type="checkbox"/>	<input checked="" type="checkbox"/>	<input checked="" type="checkbox"/>	<input type="checkbox"/>	<input type="checkbox"/>
INT. FINISH	B	1	2	3	U
PLASTER/DW	<input type="checkbox"/>	<input checked="" type="checkbox"/>	<input checked="" type="checkbox"/>	<input type="checkbox"/>	<input type="checkbox"/>
PANELING	<input type="checkbox"/>	<input type="checkbox"/>	<input type="checkbox"/>	<input type="checkbox"/>	<input type="checkbox"/>
UNFINISHED	<input checked="" type="checkbox"/>	<input type="checkbox"/>	<input type="checkbox"/>	<input type="checkbox"/>	<input type="checkbox"/>
ACCOMMODATIONS					
# OF ROOMS		5	4		
BEDROOMS			4		
FIREPLACES					
HEAT & AC	B	1	2	3	U
NO HEAT	<input type="checkbox"/>	<input type="checkbox"/>	<input type="checkbox"/>	<input type="checkbox"/>	<input type="checkbox"/>
CTRL HEAT	<input type="checkbox"/>	<input checked="" type="checkbox"/>	<input checked="" type="checkbox"/>	<input type="checkbox"/>	<input type="checkbox"/>
HW/STEAM	<input type="checkbox"/>	<input type="checkbox"/>	<input type="checkbox"/>	<input type="checkbox"/>	<input type="checkbox"/>
ELECTRIC	<input type="checkbox"/>	<input type="checkbox"/>	<input type="checkbox"/>	<input type="checkbox"/>	<input type="checkbox"/>
HEAT PUMP	<input type="checkbox"/>	<input type="checkbox"/>	<input type="checkbox"/>	<input type="checkbox"/>	<input type="checkbox"/>
FLR/WALL	<input type="checkbox"/>	<input type="checkbox"/>	<input type="checkbox"/>	<input type="checkbox"/>	<input type="checkbox"/>
STVE/SPCE	<input type="checkbox"/>	<input type="checkbox"/>	<input type="checkbox"/>	<input type="checkbox"/>	<input type="checkbox"/>
GEO THERMAL	<input type="checkbox"/>	<input type="checkbox"/>	<input type="checkbox"/>	<input type="checkbox"/>	<input type="checkbox"/>
OUTSIDE	<input type="checkbox"/>	<input type="checkbox"/>	<input type="checkbox"/>	<input type="checkbox"/>	<input type="checkbox"/>
CTRL A/C	<input type="checkbox"/>	<input checked="" type="checkbox"/>	<input checked="" type="checkbox"/>	<input type="checkbox"/>	<input type="checkbox"/>
PLUMBING	BASE <input checked="" type="checkbox"/>				
X FULL BATH		1	1		
X HALF BATH					
X FIXTURES		1			

BSMT	720		10,300
<b>SUBTOTAL</b>			253,630
MULTI-FAMILY #	0		0
BUILDING TYPE	100%		0
BSMT FINISH	360 S.F.		5,150
FIREPLACE #	0		0
HEATING	0 S.F.		0
AIR COND	2,136 S.F.		3,530
PLUMBING #	7		8,470
GARAGES & CARPORTS			9,900
EXTRA FEATURES			6,200
<b>SUBTOTAL</b>			286,880
GRADE FACTOR			115 %
<b>UNADJUSTED VALUE</b>			329,910
FACTOR			100 %

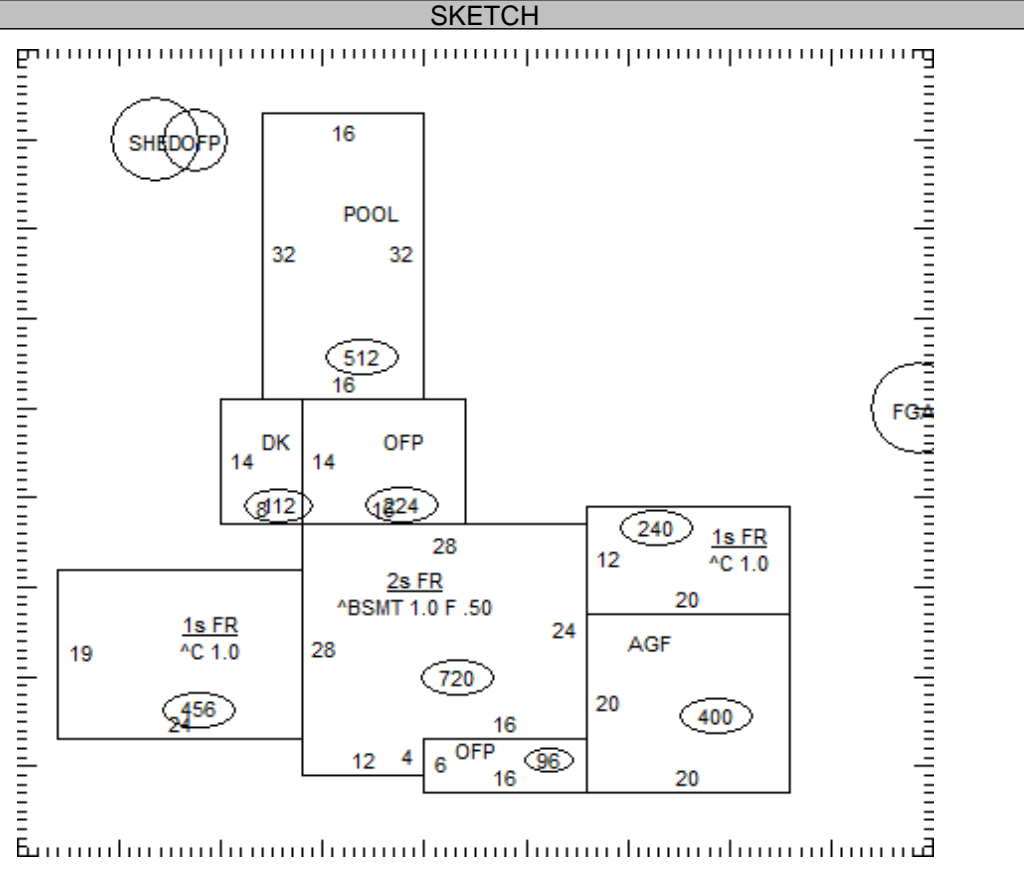

OCCUPANCY	ST.HT	SIZE	AREA	GRADE	PRICE	AGE	REMD	CND	UNADJ VAL	PHYS	PHYS VAL	FUNC	TRUE VAL
DWELLING	2	SK	2,136	B-		1993	2006	A	329,910	19	267,230		299,300
1 Gar - Frame	8	24x36	864	C	23.70	1994		A	20,480	47	10,850		10,900
2 Pool - Inground		32x16	512	C	37.50	2007		A	19,200	27	14,020		14,000
3 Shed		8x17	136	C		2019		A		4			0
4 OFF		3x17	51	C	16.04	2019		A	820	4	790		800
5													
6													
7													
8													
9													
10													
11													

26-012000.1000 TOTAL 325,000

**COMMENTS**

Dwelling has an Economic Factor of 112%

JEFFERSON TWP / CELINA SD

05-33-400-015

Property Class: 510

Neighborhood

009265-R150

Map: 04

Block:

Card: 05

Bk: Pg:

26-012000.1000

SITES DONALD L JR & MEGAN

SITES DONALD L JR & MEGAN

7143 HELLWARTH RD

CELINA, OH 45822

LEGAL INFORMATION

E SD E 1/2 SE

RTS: 002-05-33

Acres:1.2490

	OWNERSHIP	ADDRESS	CITY	STATE	ZIP	DATE	AMOUNT	DEED:CONV#	JS	VALID
1	KNOUFF CECELIA E	7143 HELLWARTH RD	CELINA	OH	45822	02/12/2003	165,000	: A : 0	<input type="checkbox"/>	<input checked="" type="checkbox"/>
2							0	0	<input type="checkbox"/>	<input type="checkbox"/>
3							0	0	<input type="checkbox"/>	<input type="checkbox"/>

X:  TTO LISTER: HK DATE: 02/03/2020 TIME: 12:00:00 AM  LETTER  LETTER REC'D GIS CODE Minor Sub

STREET/ROAD	TOPOGRAPHY	PU-UTILITIES-PR	NEIGHBORHOOD	INFLUENCE FACTORS	PROPERTY LOCATION
<input checked="" type="checkbox"/> PAVED	<input checked="" type="checkbox"/> LEVEL	<input type="checkbox"/> WATER	<input type="checkbox"/> IMPROVING	<input type="checkbox"/> A. NO ROAD	7143 HELLWARTH RD, CELINA
<input type="checkbox"/> GRAVEL	<input type="checkbox"/> HIGH	<input type="checkbox"/> SEWER	<input type="checkbox"/> STATIC	<input type="checkbox"/> B. TOPGRHY	COMMENT
<input type="checkbox"/> DIRT	<input type="checkbox"/> LOW	<input type="checkbox"/> GAS	<input type="checkbox"/> DECLINING	<input type="checkbox"/> C. Ex Front	
<input type="checkbox"/> SIDEWALKS	<input type="checkbox"/> ROLLING	<input type="checkbox"/> ELECTRIC	<input type="checkbox"/> OLD	<input type="checkbox"/> D. QUANTITY	
<input type="checkbox"/> CURBS	<input type="checkbox"/> STANDARD	<input checked="" type="checkbox"/> STANDARD	<input type="checkbox"/> STANDARD	<input type="checkbox"/> E. SZ/SHAPE	
				<input type="checkbox"/> F. RESTRICT	
				<input type="checkbox"/> G. WOOD LT	
				<input type="checkbox"/> H. VACANCY	
				<input type="checkbox"/> I. WATER FRONT	
				<input type="checkbox"/> J. OTHER/CDU	

LAND COMPUTATIONS

LAND TYPE	SIZE	M	RATE	C	INF	M	VALUE	C
Total Acres: 1.2490					TOTAL		27,500	0

VALUATION SUMMARY

VALUE YEAR	2017							
REASON FOR CHANGE	RAPP							
APPRAISED	<u>LAND</u>	18,200						
VALUE	<u>IMPR</u>	183,600						
	<u>TOTAL</u>	201,800						
ASSESSED	<u>LAND</u>	6,370						
VALUE	<u>IMPR</u>	64,260						
	<u>TOTAL</u>	70,630						

OCCUPANCY	EXTERIOR	FLOOR	AREA	CONST	VALUE
<input type="checkbox"/> SF <input type="checkbox"/> DU <input type="checkbox"/> TR	<input type="checkbox"/> WOOD				
<input type="checkbox"/> CONVERSION	<input type="checkbox"/> STUCCO				
<b>BUILDING TYPE</b>	<input type="checkbox"/> ALM/VYNL				
<input type="checkbox"/> MOBILE HOME	<input type="checkbox"/> CONC BLK				
<input type="checkbox"/> BI/TR LEVEL	<input type="checkbox"/> METAL				
<input type="checkbox"/> MOD/MAN	<input type="checkbox"/> BRICK				
<input type="checkbox"/>	<input type="checkbox"/> STONE				
ROOFING	ROOF TYPE				
<input type="checkbox"/> METAL	<input type="checkbox"/> GABLE				
<input type="checkbox"/> SLT/TLE	<input type="checkbox"/> HIP				
<input type="checkbox"/> SHINGLES	<input type="checkbox"/> GAMBREL				
<input type="checkbox"/> SHAKES	<input type="checkbox"/> MANSARD				
<input type="checkbox"/> COMPOSITE	<input type="checkbox"/> FLAT				

<b>SUBTOTAL</b>					0
MULTI-FAMILY #	0				0
BUILDING TYPE	000%				0
BSMT FINISH	0 S.F.				0
FIREPLACE #	0				0
HEATING	0 S.F.				0
AIR COND	0 S.F.				0
PLUMBING #	0				0
GARAGES & CARPORTS					0
EXTRA FEATURES					0
<b>SUBTOTAL</b>					0
GRADE FACTOR					%
<b>UNADJUSTED VALUE</b>					0
FACTOR					%

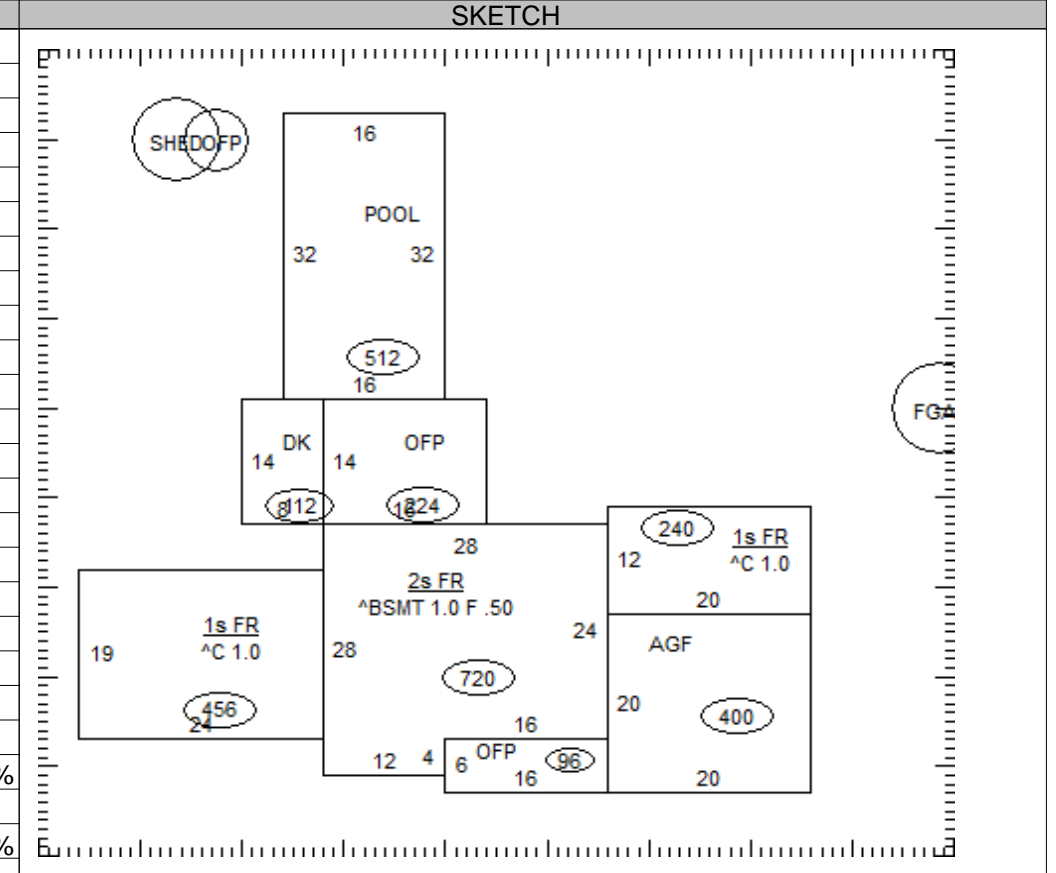

OCCUPANCY	ST.HT	SIZE	AREA	GRADE	PRICE	AGE	REMD	CND	UNADJ VAL	PHYS	PHYS VAL	FUNC	TRUE VAL
DWELLING		SK											
1													
2													
3													
4													
5													
6													
7													
8													
9													
10													
11													

26-012000.1000

TOTAL 0

COMMENTS