

HOPEWELL TWP / CELINA SD

05-27-200-008

24-033700.0200

**LEGAL INFORMATION**

PT N 1/2 SE NE

RTS: 002-05-27  
 Acres:5.7450

**HOENIE MARK D & JUDITH A**

HOENIE MARK D & JUDITH A

7865 FLEETFOOT RD

CELINA, OH 45822

Created in 2020 From 24-033700.0000 due to Split

OWNERSHIP	ADDRESS	CITY	STATE	ZIP	DATE	AMOUNT	DEED:CONV#	JS	VALID	
1	HOENIE MARK D & JUDITH A	7865 FLEETFOOT RD	CELINA	OH	45822	06/26/2020	353,000	WDC : 403	<input type="checkbox"/>	<input checked="" type="checkbox"/>
2							0	0	<input type="checkbox"/>	<input type="checkbox"/>
3							0	0	<input type="checkbox"/>	<input type="checkbox"/>

X:  TTO      LISTER: TK      DATE: 06/26/2023      TIME: 12:00:00 AM       LETTER       LETTER REC'D      GIS CODE

STREET/ROAD	TOPOGRAPHY	PU-UTILITIES-PR	NEIGHBORHOOD	INFLUENCE FACTORS	PROPERTY LOCATION	
<input type="checkbox"/> PAVED <input type="checkbox"/> GRAVEL <input type="checkbox"/> DIRT <input type="checkbox"/> SIDEWALKS <input type="checkbox"/> CURBS	<input type="checkbox"/> LEVEL <input type="checkbox"/> HIGH <input type="checkbox"/> LOW <input type="checkbox"/> ROLLING <input type="checkbox"/> STANDARD	<input type="checkbox"/> WATER <input type="checkbox"/> SEWER <input type="checkbox"/> GAS <input type="checkbox"/> ELECTRIC <input type="checkbox"/> STANDARD	<input type="checkbox"/> IMPROVING <input type="checkbox"/> STATIC <input type="checkbox"/> DECLINING <input type="checkbox"/> OLD <input type="checkbox"/> STANDARD	<input type="checkbox"/> A. NO ROAD <input type="checkbox"/> B. TOPGRHY <input type="checkbox"/> C. Ex Front <input type="checkbox"/> D. QUANTITY <input type="checkbox"/> E. SZ/SHAPE	<input type="checkbox"/> F. RESTRICT <input type="checkbox"/> G. WOOD LT <input type="checkbox"/> H. VACANCY <input type="checkbox"/> I. WATER FRONT <input type="checkbox"/> J. OTHER/CDU	7865 FLEETFOOT RD COMMENT TY2022:Net Gen=\$3,921.88, Other Assessment=\$2.00 DE23 TTO; RMV WDDK, ADD ADDTN, UPDATE BATHS PER DATA MAILER

LAND COMPUTATIONS

LAND TYPE	SIZE	M	RATE	C	INF	M	VALUE	C
HS:Home Site	AC:1	20810				20,800		0
SM:Small Acreage	AC:4.745	7700				36,500		0
Total Acres: 5.7450					TOTAL	57,300		0

VALUATION SUMMARY

VALUE YEAR	2023	2020	2020	2020	2020			
REASON FOR CHANGE	NC	RAPP	MISC	CAUV	MISC			
APPRaised	<u>LAND</u>	57,300	50,600	45,900	22,120	45,100		
VALUE	<u>IMPR</u>	295,000	183,200	165,600	165,600	165,600		
	<u>TOTAL</u>	352,300	233,800	211,500	187,720	210,700		
ASSESSED VALUE	<u>LAND</u>	20,060	17,710	16,070	7,740	15,790		
	<u>IMPR</u>	103,250	64,120	57,960	57,960	57,960		
	<u>TOTAL</u>	123,310	81,830	74,030	65,700	73,750		

OCCUPANCY	EXTERIOR	FLOOR	AREA	CONST	VALUE
<input checked="" type="checkbox"/> SF <input type="checkbox"/> DU <input type="checkbox"/> TR	<input checked="" type="checkbox"/> WOOD	1	1320	BRK	191,860
<input type="checkbox"/> CONVERSION	<input checked="" type="checkbox"/> STUCCO	1	168	FR	22,820
<b>BUILDING TYPE</b>	<input type="checkbox"/> ALM/VYNL	2ND	1140	FR	74,330
<input type="checkbox"/> MOBILE HOME	<input type="checkbox"/> CONC BLK				
<input type="checkbox"/> BI/TR LEVEL	<input type="checkbox"/> METAL				
<input type="checkbox"/> MOD/MAN	<input checked="" type="checkbox"/> BRICK				
<input type="checkbox"/>	<input type="checkbox"/> STONE				

ROOFING	ROOF TYPE
<input type="checkbox"/> METAL	<input checked="" type="checkbox"/> GABLE
<input type="checkbox"/> SLT/TLE	<input type="checkbox"/> HIP
<input checked="" type="checkbox"/> SHINGLES	<input type="checkbox"/> GAMBREL
<input type="checkbox"/> SHAKES	<input type="checkbox"/> MANSARD
<input type="checkbox"/> COMPOSITE	<input type="checkbox"/> FLAT

FLOORS	B	1	2	3	U
CONCRETE	<input checked="" type="checkbox"/>	<input type="checkbox"/>	<input type="checkbox"/>	<input type="checkbox"/>	<input type="checkbox"/>
WOOD	<input type="checkbox"/>	<input checked="" type="checkbox"/>	<input type="checkbox"/>	<input type="checkbox"/>	<input type="checkbox"/>
TILE/COMPO	<input type="checkbox"/>	<input type="checkbox"/>	<input type="checkbox"/>	<input type="checkbox"/>	<input type="checkbox"/>
CARPET	<input type="checkbox"/>	<input checked="" type="checkbox"/>	<input type="checkbox"/>	<input checked="" type="checkbox"/>	<input type="checkbox"/>

INT. FINISH	B	1	2	3	U
PLASTER/DW	<input type="checkbox"/>	<input checked="" type="checkbox"/>	<input type="checkbox"/>	<input checked="" type="checkbox"/>	<input type="checkbox"/>
PANELING	<input type="checkbox"/>	<input type="checkbox"/>	<input type="checkbox"/>	<input type="checkbox"/>	<input type="checkbox"/>
UNFINISHED	<input checked="" type="checkbox"/>	<input type="checkbox"/>	<input type="checkbox"/>	<input type="checkbox"/>	<input type="checkbox"/>

ACCOMMODATIONS					
# OF ROOMS		5		3	
BEDROOMS				3	
FIREPLACES					
HEAT & AC	B	1	2	3	U
NO HEAT	<input type="checkbox"/>	<input type="checkbox"/>	<input type="checkbox"/>	<input type="checkbox"/>	<input type="checkbox"/>
CTRL HEAT	<input type="checkbox"/>	<input checked="" type="checkbox"/>	<input checked="" type="checkbox"/>	<input checked="" type="checkbox"/>	<input type="checkbox"/>
HW/STEAM	<input type="checkbox"/>	<input type="checkbox"/>	<input type="checkbox"/>	<input type="checkbox"/>	<input type="checkbox"/>
ELECTRIC	<input type="checkbox"/>	<input type="checkbox"/>	<input type="checkbox"/>	<input type="checkbox"/>	<input type="checkbox"/>
HEAT PUMP	<input type="checkbox"/>	<input type="checkbox"/>	<input type="checkbox"/>	<input type="checkbox"/>	<input type="checkbox"/>
FLR/WALL	<input type="checkbox"/>	<input type="checkbox"/>	<input type="checkbox"/>	<input type="checkbox"/>	<input type="checkbox"/>
STVE/SPCE	<input type="checkbox"/>	<input type="checkbox"/>	<input type="checkbox"/>	<input type="checkbox"/>	<input type="checkbox"/>
GEO THERMAL	<input type="checkbox"/>	<input type="checkbox"/>	<input type="checkbox"/>	<input type="checkbox"/>	<input type="checkbox"/>
OUTSIDE	<input type="checkbox"/>	<input type="checkbox"/>	<input type="checkbox"/>	<input type="checkbox"/>	<input type="checkbox"/>
CTRL A/C	<input type="checkbox"/>	<input checked="" type="checkbox"/>	<input checked="" type="checkbox"/>	<input checked="" type="checkbox"/>	<input type="checkbox"/>

PLUMBING	BASE
X FULL BATH	
X HALF BATH	1
X FIXTURES	

FLOOR	AREA	CONST	VALUE
BSMT	570		8,150
<b>SUBTOTAL</b>			297,160
MULTI-FAMILY #	0		0
BUILDING TYPE	100%		0
BSMT FINISH	0 S.F.		0
FIREPLACE #	0		0
HEATING	0 S.F.		0
AIR COND	2,628 S.F.		4,340
PLUMBING #	5		6,050
GARAGES & CARPORTS			16,100
EXTRA FEATURES			4,600
<b>SUBTOTAL</b>			328,250
GRADE FACTOR			115 %
<b>UNADJUSTED VALUE</b>			377,490
FACTOR			100 %

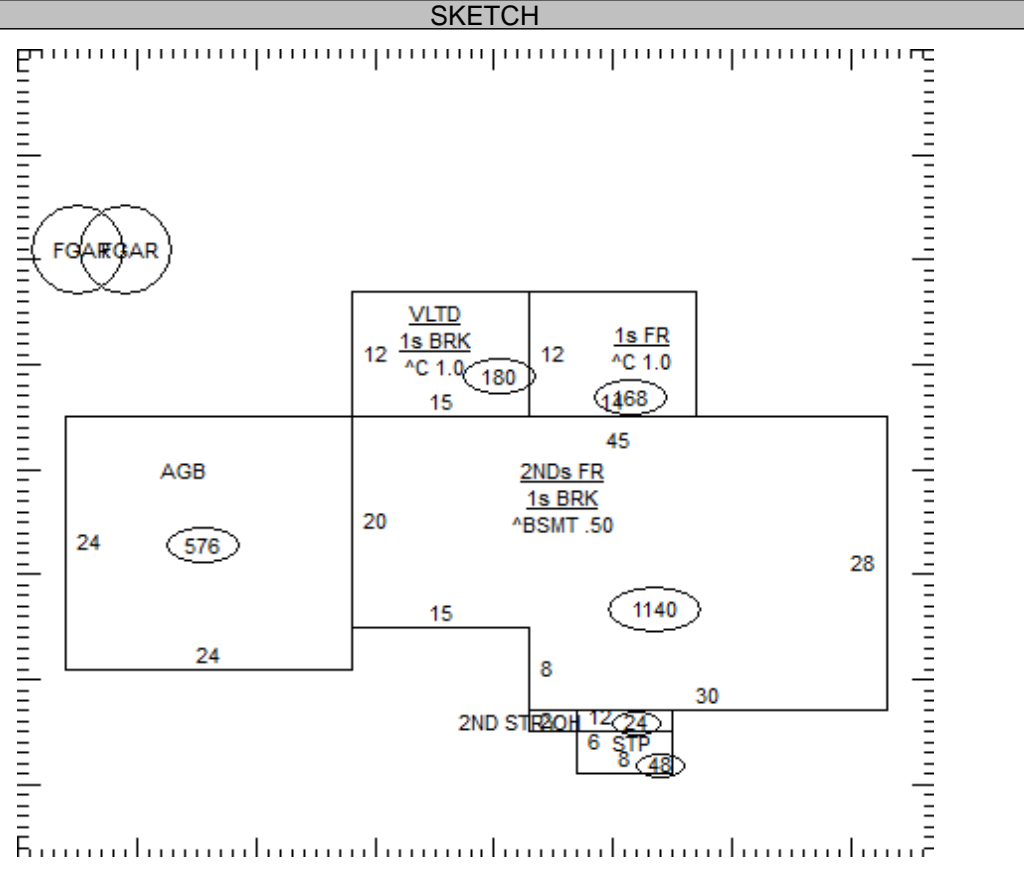

OCCUPANCY	ST.HT	SIZE	AREA	GRADE	PRICE	AGE	REMD	CND	UNADJ VAL	PHYS	PHYS VAL	FUNC	TRUE VAL
DWELLING	2	SK	2,628	B-		1986		A	377,490	26	279,340		273,800
1 Gar - Frame		32x48	1,536	C	23.70	1986		A	36,400	67	12,010		12,000
2 Gar - Frame		14x32	448	C	23.70	2014		A	10,620	13	9,240		9,200
3													
4													
5													
6													
7													
8													
9													
10													
11													

24-033700.0200

TOTAL 295,000

COMMENTS
Dwelling has an Economic Factor of 98%