



24-009600.0000

HOPEWELL TWP / CELINA SD

05-15-200-003

Page 1 of 1  
 Property Class: 510  
 Neighborhood  
 009245-R150  
 Map: 11  
 Block:  
 Card: 19  
 Bk: Pg:

**LAUTZENHEISER RYAN JAMES**  
 LAUTZENHEISER RYAN JAMES  
 4970 OREGON RD  
 CELINA, OH 45822

**LEGAL INFORMATION**  
 PT NE NE

RTS: 002-05-15  
 Acres:1.3530

	OWNERSHIP	ADDRESS	CITY	STATE	ZIP	DATE	AMOUNT	DEED:CONV#	JS	VALID
1	LAUTZENHEISER RYAN JAMES	4970 OREGON RD	CELINA	OH	45822	05/31/2019	112,000	WDC : 369	<input type="checkbox"/>	<input checked="" type="checkbox"/>
2	WEIRICK EDWARD W &	400 EAST ST	ROCKFORD	OH	45882	06/20/1988	49,000	: A : 0	<input type="checkbox"/>	<input type="checkbox"/>
3							0	0	<input type="checkbox"/>	<input type="checkbox"/>

X:  TTO LISTER: JO DATE: 10/26/2004 TIME: 09:48:46 AM  LETTER  LETTER REC'D GIS CODE

STREET/ROAD	TOPOGRAPHY	PU-UTILITIES-PR	NEIGHBORHOOD	INFLUENCE FACTORS	PROPERTY LOCATION	
<input checked="" type="checkbox"/> PAVED <input type="checkbox"/> GRAVEL <input type="checkbox"/> DIRT <input type="checkbox"/> SIDEWALKS <input type="checkbox"/> CURBS	<input checked="" type="checkbox"/> LEVEL <input type="checkbox"/> HIGH <input type="checkbox"/> LOW <input type="checkbox"/> ROLLING <input type="checkbox"/> STANDARD	<input type="checkbox"/> WATER <input type="checkbox"/> SEWER <input checked="" type="checkbox"/> GAS <input checked="" type="checkbox"/> ELECTRIC <input type="checkbox"/> STANDARD	<input type="checkbox"/> IMPROVING <input checked="" type="checkbox"/> STATIC <input type="checkbox"/> DECLINING <input type="checkbox"/> OLD <input type="checkbox"/> STANDARD	<input type="checkbox"/> A. NO ROAD <input type="checkbox"/> B. TOPGRHY <input type="checkbox"/> C. Ex Front <input type="checkbox"/> D. QUANTITY <input type="checkbox"/> E. SZ/SHAPE	<input type="checkbox"/> F. RESTRICT <input type="checkbox"/> G. WOOD LT <input type="checkbox"/> H. VACANCY <input type="checkbox"/> I. WATER FRONT <input type="checkbox"/> J. OTHER/CDU	4970 OREGON RD, CELINA <b>COMMENT</b> TY2022:Net Gen=\$1,783.36, Other Assessment=\$2.00 DE20 RMV OWN OCC; DID NOT RETURN APP

LAND COMPUTATIONS						
LAND TYPE	SIZE	M	RATE	C	INF	M VALUE C
HS:Home Site	AC:1	20810				20,800 0
SM:Small Acreage	AC:0.353	8500				3,000 0
Total Acres: 1.3530					TOTAL	23,800 0

VALUATION SUMMARY							
VALUE YEAR	2023	2020	2017				
REASON FOR CHANGE	RAPP	RAPP	RAPP				
APPRaised	<u>LAND</u>	23,800	20,900	19,000			
VALUE	<u>IMPR</u>	121,500	85,400	76,500			
	<u>TOTAL</u>	145,300	106,300	95,500			
ASSESSED	<u>LAND</u>	8,330	7,320	6,650			
VALUE	<u>IMPR</u>	42,530	29,890	26,780			
	<u>TOTAL</u>	50,860	37,210	33,430			

OCCUPANCY	EXTERIOR	FLOOR	AREA	CONST	VALUE
<input checked="" type="checkbox"/> SF <input type="checkbox"/> DU <input type="checkbox"/> TR	<input type="checkbox"/> WOOD	1	896	FR	149,090
<input type="checkbox"/> CONVERSION	<input type="checkbox"/> STUCCO	.25	224	FR	33,990
<b>BUILDING TYPE</b>	<input checked="" type="checkbox"/> ALM/VYNL				
<input type="checkbox"/> MOBILE HOME	<input type="checkbox"/> CONC BLK				
<input type="checkbox"/> BI/TR LEVEL	<input type="checkbox"/> METAL				
<input type="checkbox"/> MOD/MAN	<input type="checkbox"/> BRICK				
<input type="checkbox"/>	<input type="checkbox"/> STONE				

ROOFING	ROOF TYPE
<input type="checkbox"/> METAL	<input checked="" type="checkbox"/> GABLE
<input type="checkbox"/> SLT/TLE	<input type="checkbox"/> HIP
<input checked="" type="checkbox"/> SHINGLES	<input type="checkbox"/> GAMBREL
<input type="checkbox"/> SHAKES	<input type="checkbox"/> MANSARD
<input type="checkbox"/> COMPOSITE	<input type="checkbox"/> FLAT

FLOORS	B	1	2	3	U
CONCRETE	<input checked="" type="checkbox"/>	<input type="checkbox"/>	<input type="checkbox"/>	<input type="checkbox"/>	<input type="checkbox"/>
WOOD	<input type="checkbox"/>	<input checked="" type="checkbox"/>	<input checked="" type="checkbox"/>	<input type="checkbox"/>	<input type="checkbox"/>
TILE/COMPO	<input type="checkbox"/>	<input type="checkbox"/>	<input type="checkbox"/>	<input type="checkbox"/>	<input type="checkbox"/>
CARPET	<input type="checkbox"/>	<input type="checkbox"/>	<input type="checkbox"/>	<input type="checkbox"/>	<input type="checkbox"/>
INT. FINISH	B	1	2	3	U
PLASTER/DW	<input type="checkbox"/>	<input checked="" type="checkbox"/>	<input checked="" type="checkbox"/>	<input type="checkbox"/>	<input type="checkbox"/>
PANELING	<input type="checkbox"/>	<input type="checkbox"/>	<input type="checkbox"/>	<input type="checkbox"/>	<input type="checkbox"/>
UNFINISHED	<input checked="" type="checkbox"/>	<input type="checkbox"/>	<input type="checkbox"/>	<input type="checkbox"/>	<input type="checkbox"/>
ACCOMMODATIONS	# OF ROOMS	5	2		
BEDROOMS		1	2		
FIREPLACES		1			
HEAT & AC	B	1	2	3	U
NO HEAT	<input type="checkbox"/>	<input type="checkbox"/>	<input type="checkbox"/>	<input type="checkbox"/>	<input type="checkbox"/>
CTRL HEAT	<input type="checkbox"/>	<input checked="" type="checkbox"/>	<input checked="" type="checkbox"/>	<input type="checkbox"/>	<input type="checkbox"/>
HW/STEAM	<input type="checkbox"/>	<input type="checkbox"/>	<input type="checkbox"/>	<input type="checkbox"/>	<input type="checkbox"/>
ELECTRIC	<input type="checkbox"/>	<input type="checkbox"/>	<input type="checkbox"/>	<input type="checkbox"/>	<input type="checkbox"/>
HEAT PUMP	<input type="checkbox"/>	<input type="checkbox"/>	<input type="checkbox"/>	<input type="checkbox"/>	<input type="checkbox"/>
FLR/WALL	<input type="checkbox"/>	<input type="checkbox"/>	<input type="checkbox"/>	<input type="checkbox"/>	<input type="checkbox"/>
STVE/SPCE	<input type="checkbox"/>	<input type="checkbox"/>	<input type="checkbox"/>	<input type="checkbox"/>	<input type="checkbox"/>
GEO THERMAL	<input type="checkbox"/>	<input type="checkbox"/>	<input type="checkbox"/>	<input type="checkbox"/>	<input type="checkbox"/>
OUTSIDE	<input type="checkbox"/>	<input type="checkbox"/>	<input type="checkbox"/>	<input type="checkbox"/>	<input type="checkbox"/>
CTRL A/C	<input type="checkbox"/>	<input checked="" type="checkbox"/>	<input checked="" type="checkbox"/>	<input type="checkbox"/>	<input type="checkbox"/>
PLUMBING					<input checked="" type="checkbox"/>
X FULL BATH					
X HALF BATH					
X FIXTURES					

BSMT	896		12,810
<b>SUBTOTAL</b>			195,890
MULTI-FAMILY #	0		0
BUILDING TYPE	100%		0
BSMT FINISH	0 S.F.		0
FIREPLACE #	1		4,400
HEATING	0 S.F.		0
AIR COND	1,120 S.F.		1,850
PLUMBING #	0		0
GARAGES & CARPORTS			14,200
EXTRA FEATURES			8,700
<b>SUBTOTAL</b>			225,040
GRADE FACTOR			100 %
<b>UNADJUSTED VALUE</b>			225,040
FACTOR			100 %

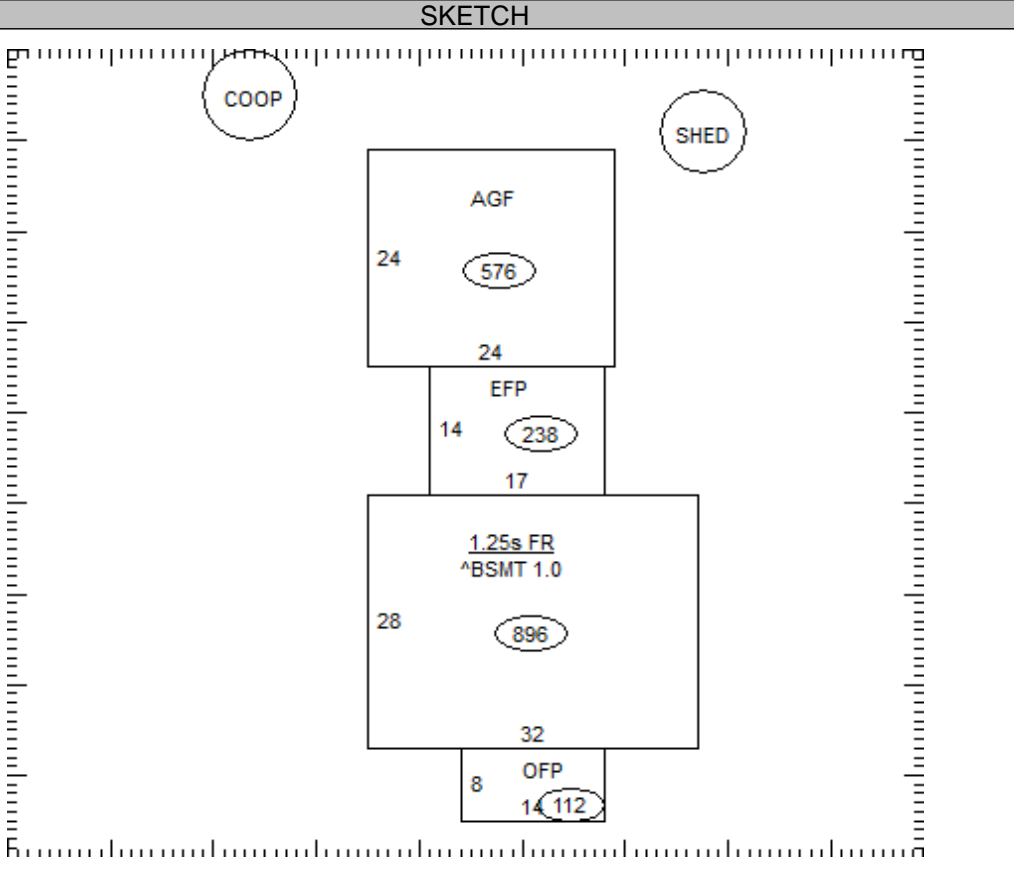

OCCUPANCY	ST.HT	SIZE	AREA	GRADE	PRICE	AGE	REMD	CND	UNADJ VAL	PHYS	PHYS VAL	FUNC	TRUE VAL
DWELLING	1.25	SK	1,120	C		1947		A	225,040	45	123,770		121,300
1 Coop	SV*	16x40	640	D		1948		P		95		DFLT50	200
2 Shed		6x10	60	D		1960		P		95			0
3													
4													
5													
6													
7													
8													
9													
10													
11													

24-009600.0000 \* Value Override Item TOTAL 121,500

COMMENTS

O5 RVL NEWER VINYL SIDING AND WINDOWS  
Dwelling has an Economic Factor of 98%